

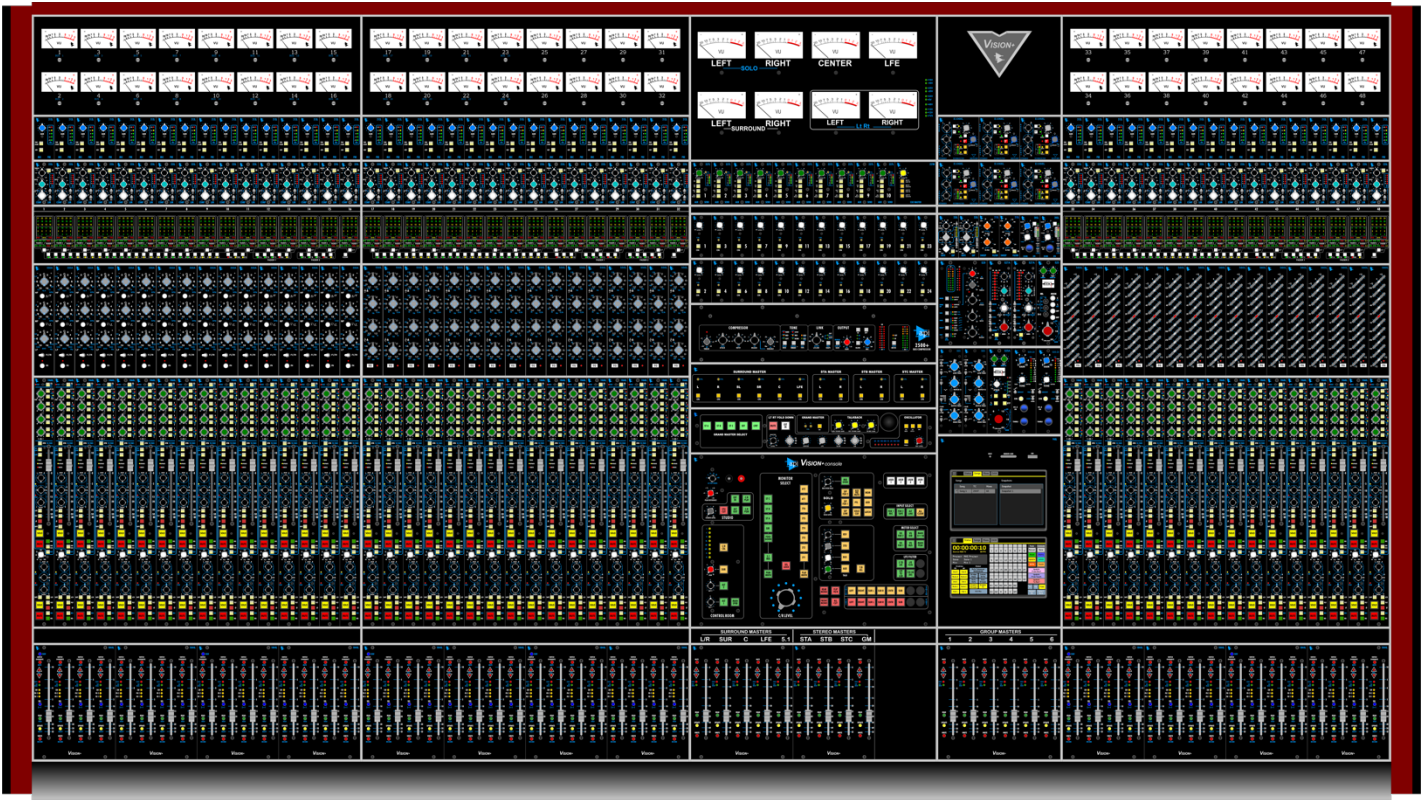

# User's Manual



Written for Automated Processes, Inc.  
by Dan Pfeifer  
Rev. 2025-07-13



**Automated Processes, Inc.**

**8301 Patuxent Range Road  
Jessup, MD 20794 USA  
301-776-7879  
<http://www.apiaudio.com>**

©2025 Automated Processes, Inc.  
All rights reserved under International  
and Pan-American Copyright Conventions.

API® and the double-spear logo are registered trademarks of Automated Processes, Inc.

*Final Touch Automation*® is a registered trademark of Automated Processes, Inc.

No part of this publication may be reproduced in any form or by any means, whether mechanical or electronic, without the written permission of Automated Processes, Inc.

As research and development is a continual process, API reserves the right to change the features and specifications described herein without notice or obligation. API cannot be held responsible for any loss or damage arising directly or indirectly from any error or omission in this manual.

**PLEASE READ ALL INSTRUCTIONS, PAY SPECIAL HEED TO SAFETY WARNINGS**

# Table of Contents

<b>About This Manual .....</b>	<b>0</b>
<b>1.0 Introduction .....</b>	<b>1</b>
<b>1.1 Overview and Features .....</b>	<b>1</b>
1.1.1 Overview .....	1
1.1.2 Configurability .....	2
1.1.3 Major Features .....	2
1.1.4 Channel Features.....	2
1.1.5 Central Facilities .....	3
1.1.6 Also Featuring .....	4
<b>1.2 Major Frame Sections .....</b>	<b>5</b>
1.2.1 Channel Buckets.....	7
1.2.1.1 Upper 200L Slots.....	7
1.2.1.2 Lower 200L Slots.....	8
1.2.1.3 500L EQ Slot.....	8
1.2.1.4 1068L Input Module.....	8
1.2.1.5 1044L Fader 1 Module.....	9
1.2.1.6 Channel VU Meter.....	9
1.2.2 Center Section.....	9
1.2.3 Options Bucket.....	10
1.2.3.1 Options Bucket Patch Points.....	11
1.2.4 Optional Producer's Desk .....	11
1.2.5 Patch Bays.....	12
<b>2.0 Channel Signal Flow.....</b>	<b>13</b>
<b>2.1 Dual Signal Path Channel Architecture .....</b>	<b>13</b>
<b>2.2 Channel Strip Components .....</b>	<b>15</b>
<b>2.3 Channel Strip Full Block Diagram .....</b>	<b>16</b>
<b>2.4 Channel Strip Front-End Signal Flow .....</b>	<b>17</b>
2.4.1 Mic Path Signal Flow .....	17
2.4.2 Line Path Signal Flow .....	17
2.4.3 Front-End Signal Flow .....	18
<b>2.5 Channel Strip Patch Points.....</b>	<b>19</b>
<b>2.6 1068L Input Module Signal Flow .....</b>	<b>20</b>
2.6.1 1068L Fader 1 Signal Flow .....	21
2.6.2 1068L Fader 2 Signal Flow .....	21
<b>2.7 Channel Input Path Source Selection.....</b>	<b>22</b>
<b>2.8 Channel Signal Processing .....</b>	<b>22</b>
<b>2.9 Channel Output Assignments .....</b>	<b>23</b>
<b>3.0 Channel Strip Controls.....</b>	<b>25</b>
<b>3.1 Input Selectors.....</b>	<b>25</b>

3.1.1 Global Input Selectors (INPUT SELECT) .....	25
3.1.2 1068L V3 Input Selectors.....	26
<b>3.2 Channel Preamplifier Modules.....</b>	<b>27</b>
3.2.1 Upper 200L Slot Channel Strip Integration .....	27
3.2.2 212L Microphone Preamplifier.....	28
3.2.3 205L Direct Input .....	29
<b>3.3 Channel Signal Processing Modules.....</b>	<b>30</b>
3.3.1 Lower 200L Slot Channel Integration.....	30
3.3.2 225L Compressor/Limiter.....	31
3.3.3 215L Sweep Filter .....	32
3.3.4 235L Gate/Expander .....	33
<b>3.4 Channel Equalization Modules.....</b>	<b>34</b>
3.4.1 500L EQ Slot Channel Integration .....	34
3.4.2 550AL 3-Band Equalizer.....	35
3.4.3 550L 4-Band Equalizer .....	37
3.4.4 560L 10-Band Graphic Equalizer .....	39
<b>3.5 1068L V3 Input Module.....</b>	<b>40</b>
3.5.1 1068L V3 Input Module Controls.....	42
3.5.1.1 Equalizer Routing.....	42
3.5.1.2 Auxiliary Sends .....	43
3.5.1.3 Lower 200L Slot (Dynamics) Routing.....	45
3.5.1.4 Fader 2 Controls.....	46
3.5.1.5 Fader 1 Controls.....	52
3.5.1.6 1068L Routing/Snapshot Control .....	57
3.5.1.7 1068L Automation Controls.....	59
<b>3.6 Channel Faders.....</b>	<b>60</b>
3.6.1 Fader 1 .....	60
3.6.2 Fader 2 .....	61
3.6.3 Position Faders.....	62
<b>3.7 Channel Meters and Peak Indicators .....</b>	<b>64</b>
3.7.1 Channel VU Meters.....	64
3.7.2 1068L Channel Peak Indicators.....	65
<b>3.8 Channel Patch Points .....</b>	<b>66</b>
3.8.1 Patch Bay Normals.....	67
3.8.2 Channel Patch Point Details and Normals .....	67
3.8.2.1 Mic Path and Fader 2 Patch Points.....	67
3.8.2.2 Line Path and Fader 1 Patch Points .....	68
<b>4.0 Channel Output Routing.....</b>	<b>70</b>
<b>4.1 Channel Direct Output.....</b>	<b>71</b>
<b>4.2 Channel Output Assignment Module.....</b>	<b>71</b>
4.2.1 Channel Output Assignment Display .....	72
4.2.2 Multitrack Summing Bus Assignments .....	72
4.2.3 Program Bus Assignments .....	73
4.2.4 Multitrack Summing Bus Assignment Procedure.....	75
4.2.5 Program Bus Assignment Procedure .....	75

4.2.6 Aux 9/10 to Multitrack 1-8 Assignment Procedure.....	75
<b>4.3 Channel Setup and Routing Via Software.....</b>	<b>77</b>
<b>5.0 Multitrack Summing Buses .....</b>	<b>79</b>
<b>5.1 Multitrack Summing Buses.....</b>	<b>79</b>
<b>5.2 Multitrack Output Modules .....</b>	<b>80</b>
5.2.1 Multitrack Output Controls .....	80
<b>5.3 Multitrack Patch Points .....</b>	<b>81</b>
<b>5.4 Multitrack Summing Bus Signal Flow .....</b>	<b>81</b>
<b>6.0 Stereo Program Masters .....</b>	<b>82</b>
<b>6.1 Stereo Program Buses A, B, and C.....</b>	<b>82</b>
<b>6.2 Stereo Grand Master .....</b>	<b>83</b>
6.2.1 Grand Master Select.....	84
<b>6.3 Stereo Program Master Faders .....</b>	<b>85</b>
<b>6.4 Optional 2500+C Stereo Bus Compressor .....</b>	<b>87</b>
<b>6.5 Stereo Program Output Modules .....</b>	<b>88</b>
6.5.1 Stereo Program Output Controls .....	88
<b>6.6 Stereo Program Patch Points .....</b>	<b>89</b>
<b>6.7 Stereo Program Signal Flow .....</b>	<b>90</b>
<b>7.0 Surround Program Masters .....</b>	<b>91</b>
<b>7.1 5-Channel Surround Program Buses.....</b>	<b>92</b>
<b>7.2 Surround Program Master Faders.....</b>	<b>94</b>
<b>7.3 LFE Feed.....</b>	<b>95</b>
7.3.1 LFE Filter .....	96
7.3.1.1 LFE Feed from 5 TO LFE .....	96
7.3.1.2 LFE Feed from a Mono Auxiliary Send.....	98
7.3.1.3 LFE Feed from a Multitrack Summing Bus .....	99
7.3.1.4 LFE Feed from an Unfiltered External Source.....	100
7.3.1.5 LFE Feed from a Filtered External Source.....	100
7.3.1.6 LFE Patch Points .....	100
<b>7.4 E1068L Surround Effects Return Module.....</b>	<b>101</b>
7.4.1 E1068L Surround Return Controls.....	101
7.4.2 E1068L Surround Return Patch Points .....	103
7.4.3 E1068L Surround Return Signal Flow.....	104
<b>7.5 Surround Program Output Modules .....</b>	<b>105</b>
7.5.1 Surround Program Output Controls .....	105
<b>7.6 Surround Program Patch Points .....</b>	<b>106</b>
<b>7.7 Surround Program Signal Flow.....</b>	<b>107</b>
<b>8.0 Surround to Lt Rt Fold Down.....</b>	<b>108</b>
<b>8.1 Lt Rt Fold Down Controls.....</b>	<b>108</b>

8.2 Lt Rt Fold Down Patch Points .....	110
<b>9.0 Auxiliary Send Masters .....</b>	<b>111</b>
9.1 Auxiliary Send Buses .....	111
9.2 227L Auxiliary Send Output Modules .....	111
9.2.1 227L Auxiliary Send Output Module Controls .....	112
9.3 227M Cue Master Module .....	113
9.3.1 227M Cue Master Controls .....	114
9.4 Auxiliary Send Patch Points .....	115
9.5 Auxiliary Send Signal Flow .....	115
<b>10.0 Control Group Master Faders .....</b>	<b>116</b>
<b>11.0 Solo System .....</b>	<b>118</b>
11.1 Solo Modes .....	118
11.2 Solo Controls .....	119
11.3 Solo Bus Access Patch Points .....	121
<b>12.0 Talkback .....</b>	<b>122</b>
12.1 Control Room Talkback .....	122
12.2 External Talkback .....	122
12.3 Reverse Talkback.....	122
12.4 Talkback Mic and Preamp Controls .....	123
12.5 Talkback Routing Controls.....	124
12.6 Assigning Talkback to Auxiliary Send .....	124
12.7 Talkback Patch Points.....	125
<b>13.0 Control Room Monitor Control.....</b>	<b>126</b>
13.1 Control Room Stereo Monitoring.....	127
13.2 Control Room Surround Monitoring .....	127
13.3 Control Room Monitor Source Selection .....	129
13.3.1 Control Room Source Selectors and Level Control .....	130
13.3.2 LFE TO LCR .....	132
13.4 Control Room Monitor System Selection .....	133
13.4.1 Control Room Monitor Controls .....	134
13.5 Monitor Output Test Points .....	137
13.6 Control Room Monitor Patch Points .....	137
<b>14.0 Studio Monitor Control.....</b>	<b>140</b>
14.1 Studio Stereo and Surround Monitoring.....	140
14.2 Studio Monitor Controls .....	141
14.3 Studio Monitor Patch Points .....	142
<b>15.0 Sine Wave Oscillator .....</b>	<b>143</b>

<b>15.1 Oscillator Controls .....</b>	<b>143</b>
<b>15.2 Oscillator Patch Point.....</b>	<b>144</b>
<b>16.0 User Switches .....</b>	<b>144</b>
<b>17.0 Meters and Peak Indicators .....</b>	<b>145</b>
<b>17.1 VU Meter Bridge.....</b>	<b>145</b>
17.1.1 Channel Meters.....	146
17.1.2 Main Meters .....	147
17.1.3 Meter Controls (METER SELECT) .....	148
<b>17.2 1068L Channel Peak Indicators .....</b>	<b>149</b>
<b>17.3 Power Supply Voltage Indicators.....</b>	<b>149</b>
<b>18.0 Patch Bays .....</b>	<b>150</b>
<b>18.1 Patch Bay Normalling Conventions .....</b>	<b>151</b>
<b>18.2 Channel Patch Points .....</b>	<b>151</b>
18.2.1 Channel Patch Point Details and Normals .....	152
18.2.2 Mic Path and Fader 2 Patch Points .....	153
18.2.3 Line Path and Fader 1 Patch Points.....	154
<b>18.3 Channel Bay Multitrack Patch Points .....</b>	<b>154</b>
<b>18.4 System Bay 1 .....</b>	<b>155</b>
18.4.1 Options Bucket Patch Points .....	155
18.4.2 Auxiliary Send Patch Points .....	156
18.4.3 Phase Reverse and Multiple Patch Points .....	156
<b>18.5 System Bay 2.....</b>	<b>156</b>
18.5.1 Stereo Program Patch Points .....	157
18.5.2 Surround Program Patch Points.....	157
18.5.3 Lt Rt Fold Down Patch Points .....	158
18.5.4 Studio Monitor External Input Patch Points.....	158
18.5.5 Oscillator Patch Point.....	158
<b>18.6 System Bay 3.....</b>	<b>159</b>
18.6.1 System Bay 3 Multitrack Patch Points .....	159
18.6.2 System Bay 3 Stereo Program Bus Patch Points.....	159
18.6.3 Control Room Monitor Patch Points.....	160
18.6.4 Studio Monitor Patch Points.....	161
18.6.5 Talkback Patch Points .....	161
<b>18.7 Custom User Patch Bay .....</b>	<b>162</b>
<b>19.0 Final Touch Automation® .....</b>	<b>163</b>
<b>19.1 1068L Routing/Snapshot Control .....</b>	<b>164</b>
<b>19.2 Automated Controls .....</b>	<b>165</b>
<b>Appendix .....</b>	<b>166</b>
<b>A1 1068L V2 Input Module .....</b>	<b>167</b>
<b>A1.1 1068L V2 Input Module Controls .....</b>	<b>169</b>
A1.1.1 Equalizer Routing .....	169

A1.1.2 Auxiliary Sends.....	170
A1.1.3 Tape Pad .....	172
A1.1.4 Fader 2 Controls .....	173
A1.1.5 Fader 1 Controls .....	178
A1.1.6 1068L V2 Routing/Snapshot Control .....	182
A1.1.7 1068L V2 Automation Controls .....	184
A1.1.8 1068L V2 Routing Page.....	185
<b>A2 Front-End Signal Flow.....</b>	<b>186</b>
<b>A3 Channel Block Diagram .....</b>	<b>186</b>
<b>A4 Monitor Block Diagram .....</b>	<b>187</b>
<b>A5 212L Microphone Preamp Specifications .....</b>	<b>188</b>
<b>A6 212L Recall Sheet.....</b>	<b>189</b>
<b>A7 205L Direct Input Specifications .....</b>	<b>190</b>
<b>A8 205L Direct Input Recall Sheet.....</b>	<b>191</b>
<b>A9 215L Sweep Filter Specifications.....</b>	<b>192</b>
<b>A10 225L Compressor/Limiter Specifications .....</b>	<b>193</b>
<b>A11 225L Compressor/Limiter Recall Sheet .....</b>	<b>194</b>
<b>A12 235L Gate/Expander Specifications.....</b>	<b>195</b>
<b>A13 235L Noise Gate Recall Sheet.....</b>	<b>196</b>
<b>A14 550AL 3-Band EQ Specifications.....</b>	<b>197</b>
<b>A15 550AL 3-Band EQ Recall Sheet .....</b>	<b>198</b>
<b>A16 550L 4-Band EQ Specifications.....</b>	<b>198</b>
<b>A17 550L 4-Band EQ Recall Sheet .....</b>	<b>200</b>
<b>A18 560L 10-Band Graphic EQ Specifications .....</b>	<b>201</b>
<b>A19 560L 10-Band Graphic EQ Recall Sheet.....</b>	<b>202</b>
<b>A20 2500+C Bus Compressor Specifications.....</b>	<b>203</b>
<b>A21 2500+C Bus Compressor Block Diagram.....</b>	<b>203</b>
<b>A22 2500+C Bus Compressor Recall Sheet .....</b>	<b>204</b>
<b>A23 API Limited Warranty and Service.....</b>	<b>205</b>

# About This Manual

This manual explains the operation and applications of the latest version API's flagship recording console, the *Vision+*.

The specifics of the signal flow architecture, signal routing, channel modules, master modules, ancillary modules, and other console systems are described in detail in separate sections. The *Final Touch Automation*® system is briefly addressed, but is fully explained in a separate manual. Any remaining console functions and features are also discussed in separate sections.

The two channel signal paths in the *Vision+* may be referred to interchangeably as follows:

- "LINE PATH," "Fader 1," "Multitrack Return path," and/or "Monitor path"
- "MIC PATH," "Fader 2," "Multitrack Send path," and/or "Channel path"

This terminology uses the same conventions used on other API consoles including the AXS console.

## Legend:

- **Bold Lower-case = Modules and sections as needed for clarity**
- **UPPER-CASE BOLD = SWITCHES, SWITCHES, POTS, & FADERS**
- UPPER-CASE = PATCH BAY CONNECTIONS, MIC PATH, and LINE PATH
- *Italic lower-case = NOTES*

## Manual Revision History: YYYY-MM-DD format

Original: ????-??-??

Revised: 2009-01-15

Revised: 2009-10-23

Revised: 2010-10-14

Revised: 2016-06-01

Revised: 2025-07-13

**Dan Pfeifer is a Professor Emeritus  
of Recording Industry at  
Middle Tennessee State University**

# 1.0 Introduction

API's *Vision+* responds to the major advances in digital audio, music recording, media production, and stereo and surround mixing. Digital media demands a new level of performance, reliability and flexibility from the professional tools used to create audio masters. From the mic amps and equalizers, to the signal processing devices and right through the bus and routing structures of an audio console, we applaud the rising levels of sonic expectation today's audio performances demand. Accordingly, API proudly presents the third version of their flagship *Vision* recording and mixing console (*Vision+*), built to the same exacting standards of reliability, sonic performance, and investment grade audio that has made the API consoles the standard of modern recording consoles. *Vision+* is dedicated to all those who hear, appreciate, and demand the best.

## 1.1 Overview and Features

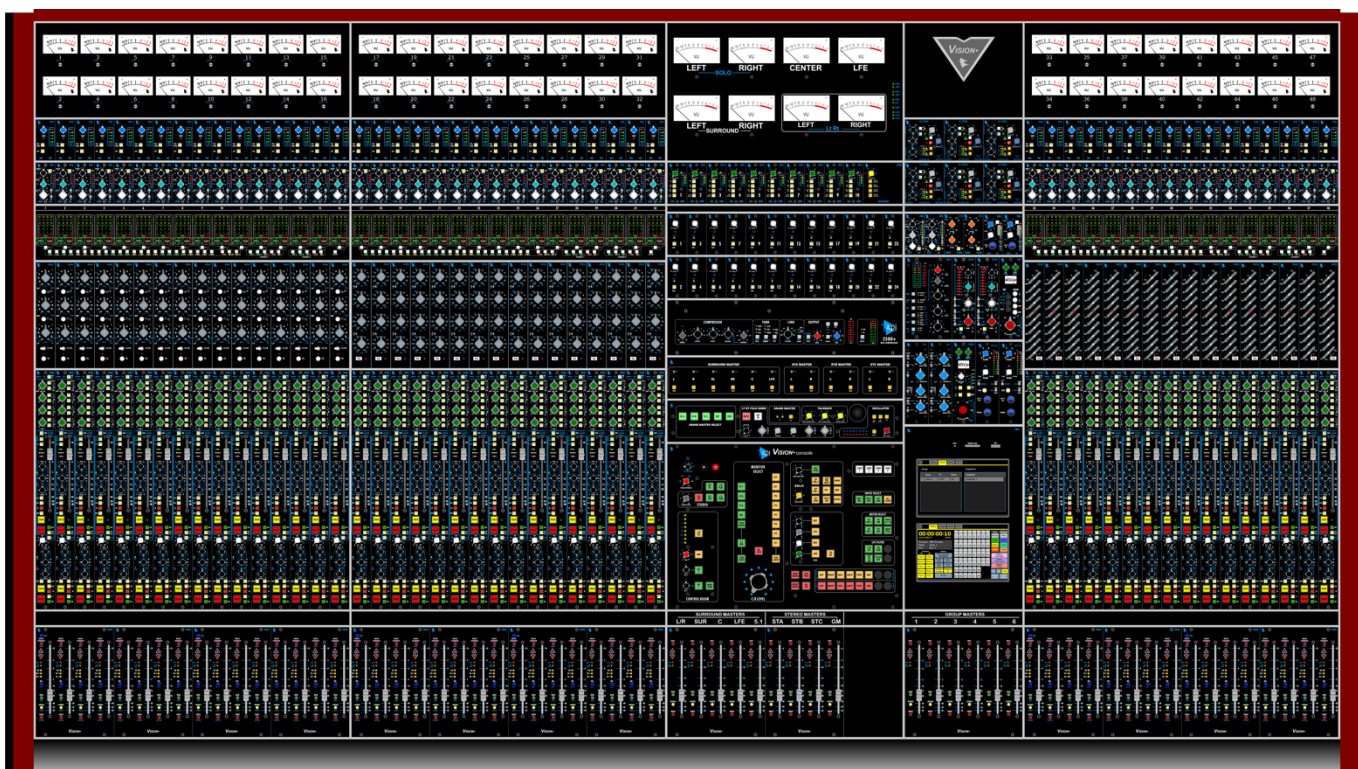

### 1.1.1 Overview

The *Vision+* is the latest evolution of API's flagship stereo and surround mixing and recording console. The *Vision+* features dual audio path channel architecture, a 24-bus multitrack routing matrix, independent stereo and surround program bus assignments, and independent panning on each fader. Comprehensive channel and central facilities. Unlike many other large-format consoles, both channel faders are fully automatable, along with several switched channel functions like aux on/off, insert in/out, and EQ bypass via comprehensive integration with API's *Final Touch Automation*® system.

## 1.1.2 Configurability

- Customizable frame and module configurations:
  - 16-channel module buckets yielding 48, 64, 80, and 96+ channel frame sizes
  - Two 200 series module slots on each channel
  - Configurable options bucket for optional E1068L effects return modules and/or addition 200L and 500 Series modules
  - Optional 2500+C stereo bus compressor
  - Optional producer desk
  - Bolster and trim options

## 1.1.3 Major Features

- Simultaneous surround and stereo mixing:
  - Three independent stereo program buses and outputs: A, B, & C
  - Grand Master stereo bus program bus summing and outputs: GM
  - 5-channel surround program bus with 5.1 outputs: L-R, SI-Sr, C, LFE
  - Comprehensive set of fully-automatable master faders
  - Surround to stereo Lt Rt fold down matrix and outputs: Lt Rt
  - Individual stereo and surround program output calibration
  - Individual stereo and surround program output **ON**/off switches
  - Extensive program bus patch capability for flexible mix processing
  - Optional 2500+C stereo bus compressor
- Twenty-four multitrack summing buses
- All analog signal paths and summing
- Transformer outputs
- Analog meter bridge with power supply indicators
- Fully-compatible with API's *Final Touch Automation*<sup>®</sup> system:
  - Automated moving faders on *both* channel paths (Fader 1 & Fader 2)
  - Automated mute and inserts on both channel paths (Fader 1 & Fader 2)
  - Automated EQ bypass and auxiliary send **ON**/off on all channels
  - Automated moving faders on all stereo and surround program masters
  - Automated moving faders and mutes on all control group master faders
  - Recallable bus routing, fader, mute, and switch snapshots

## 1.1.4 Channel Features

- Dual signal path architecture (two independent audio paths, Fader 1 & Fader 2)
- Three channel inputs: **MIC**, **LINE**, and **ALT LINE** (ALT MULTITRACK OUTPUT)
  - Global input routing selectors for **MIC** and **LINE** sources
- Two 100mm automated moving faders, one for each path
- LED peak indicators on both audio paths with reference level set globally
- Balanced direct output
- Fader 1, Fader 2, or direct output can be shown on channel meters
- Simultaneous stereo and surround panning on each path
- Ten auxiliary sends:
  - Six mono: 1, 2, 3, 4, 5, and 6 with individual **ON**/off switches
  - Two stereo: 7-8 and 9-10 switched **ON**/off in pairs
  - Automated aux **ON**/off switches
  - Switchable between Fader 1 or Fader 2 path in pairs (1-2, 3-4, etc.)
  - Switchable pre or post fader in pairs (1-2, 3-4, etc.)
  - Pre-fader auxiliaries can be set to mute when the channel path is muted

- Recallable routing and **ON**/off via automation and snapshots
- Individual auxiliary send master modules with comprehensive controls
- GM and Lt Rt routing to auxiliary masters 7-8 and/or 9-10
- 40-600Hz high-pass sweep filter in Fader 1 path
- 50Hz fixed high-pass filter in Fader 2 path
- Channel equalizer options (as fitted):
  - 550AL 3-band semi-parametric EQ
  - 550L 4-band semi-parametric EQ
  - 560L 10-band Graphic
  - Automated EQ bypass
  - Assignable to MIC PATH (Fader 2) or LINE PATH (Fader 1)
- Upper 200 slot input module options (as fitted):
  - 212L Microphone Preamplifier
  - 205L Direct Input
- Lower 200 slot processing module options (as fitted):
  - 215L Sweep Filter set
  - 225L Compressor/Limiter
  - 235L Gate/Expander
  - Assignable to MIC PATH (Fader 2) or LINE PATH (Fader 1)
- Balanced insert in each path; MIC PATH (Fader 2) and LINE PATH(Fader 1)
- Phase reverse (polarity inverter) in each path (Fader 1 & Fader 2)
- Fader 1 output to Fader 2 input routing
- Solo with four solo mode and recallable solo safe switch on both fader paths

## 1.1.5 Central Facilities

- Comprehensive monitor source selections:
  - Five stereo program selectors: **STA, STB, STC, GM,** and **FOLD DOWN**
  - One surround program selector: **5.1**
  - Six stereo external playback selectors: **2T1, 2T2, 2T3, 2T4, 2T5,** and **2T6**
  - Two 6-channel surround external playback selectors: **6T1** and **6T2**
  - Monitor source selection lock
- Comprehensive monitor output controls:
  - Stereo and 5.1 surround monitoring
  - Three control room monitor outputs: **MAIN SPKR, ALT 1,** and **ALT 2** with level controls and trims
  - Large control room level control
  - **CR CAL** switch for preset calibrated control room level
  - **DIM** switch with level control
  - Individual mute and solo controls for each output
  - Selectable front-panel monitor output test points
  - Comprehensive mono summing and monitor flip function
  - Mono sum of stereo sources for subwoofer feed
  - Comprehensive studio loudspeaker controls that support two systems
- Comprehensive solo system:
  - Four solo modes: AFL (default), PFL, SIP, and Mix Over Solo
  - Solo-In-Place (SIP) can be assigned separately on Fader 1 and Fader 2
  - Solo-In-Place (SIP) on Fader 1 and Fader 2 can be linked
  - Momentary, additive, and latched solo engagement options
  - Solo clear function
- 24 multitrack summing buses:
  - Individual bus output trim pots with front-panel knobs
  - Individual illuminated bus output **ON**/off switches

- Output can be shown on channel meters
- Talkback microphone, preamp level, and routing
- Reverse talkback microphone preamp and level
- Comprehensive analog meter bridge:
  - Channel meters can display Fader 1, Fader 2, direct output, or multitrack bus output
  - Program meters follow the selected monitor source
- *Final Touch Automation*® control module (ACM) with dual displays to facilitate:
  - File creation and management for projects
  - Global and individual channel input and output assignments
  - Global and individual channel recall switch setups
  - Snapshot creation, storage, and recall
  - Comprehensive fader, mute, and switch automation
  - DAW control
- Options Bucket for effects returns and additional signal processing:
  - Two rows of 200L slots: 3 E1068L modules or 6 200L modules
  - One row of 200L only slots: 6 200L modules
  - Two rows of 500 Series slots
  - Options Bucket module options:
    - E1068L: Stereo/surround effects return for Vision consoles
    - Any 200L series module
    - Any standard 500 series module
- Comprehensive, fully-balanced channel and system external patch bay
- Optional producer's desk

### 1.1.6 Also Featuring

- The legendary API sound
- The same exacting craftsmanship featured on all API consoles
- Heavy-duty frame and metal parts
- Highest quality leather and wood trim
- Custom built to client's specification
- API's unique customer service and 5 year warranty

## 1.2 Major Frame Sections

The *Vision+* console frame comes in a variety of frame sizes built with a center section, options bucket, and three or more 16-channel channel buckets. The smallest frame size is 48 channels, ranging up to 96 channels.

Each channel bucket provides facilities for up to sixteen (16) channels. Each channel provides a slot for a 1068L input module, two 200L slots (one for preamplification and one for additional signal processing such as a dynamics module), 500L equalizer slot, and bay for Fader 1 faders. A routable VU meter is provided for each channel in the meter bridge.

The center section contains the stereo and surround program bus masters and faders, optional 2500+C stereo bus compressor, stereo grand master and surround fold-down summing, multitrack summing bus masters, auxiliary bus masters, monitor control, talkback, and a routable test tone oscillator. Large VU meters are provided for the selected monitor source in the meter bridge.

An options bucket is located next to the center section and provides two (2) 200L rows for up to three (3) E1068L effects return modules or up to six (6) 200L signal processing modules per row. A third row of 200L slots is provided for up to six (6) additional 200L signal processing modules per row. Two (2) rows of standard 500 slots provide support up to 10 standard 500 Series modules. All options bucket modules interfacing is available in the patch bay.

*Vision+* consoles are equipped with the API *Final Touch Automation*<sup>®</sup> system that provides project file management, moving fader and switch automation, channel parameter and bus assignment routing, recallable snapshot system, and DAW control. The Automation Control Module (ACM) with two touch-screens are located below the options bucket.

Six (6) assignable control group master faders are located below the *Final Touch Automation*<sup>®</sup> touch-screens.

The patch bays are typically remotely mounted, but onboard patch bays can be specified as an option when the console is ordered.

A producer's desk/DAW workstation is also available as an option when the console is specified.

Due to this flexible design and broad selection of available 200L, 500L, and 500 modules, as well as the E1068L effects return modules, each *Vision+* console may be outfitted and configured in many different ways. The modular aspects of *Vision+* consoles allow reconfiguration and growth, so channel and options bucket assets can be easily added to or repositioned over time, helping avoid obsolescence and protecting the investment. With this kept in mind, it should be noted that each *Vision+* console is built and equipped to meet the specifications determined by the owner, so each console has its own "personality." While work flow, capacity, and patching may vary by configuration, the basic operational premise of all *Vision* consoles is essentially the same.

*NOTE: All original console parameters, including frame size and configuration, standard or alternate signal flow, the number and location of all installed channel and options bucket modules, patch bay configuration and mounting, optional producer's desk, and the optional 2500+C Stereo Bus Compressor are determined at the time of console specification.*

The graphic below identifies the major console sections.

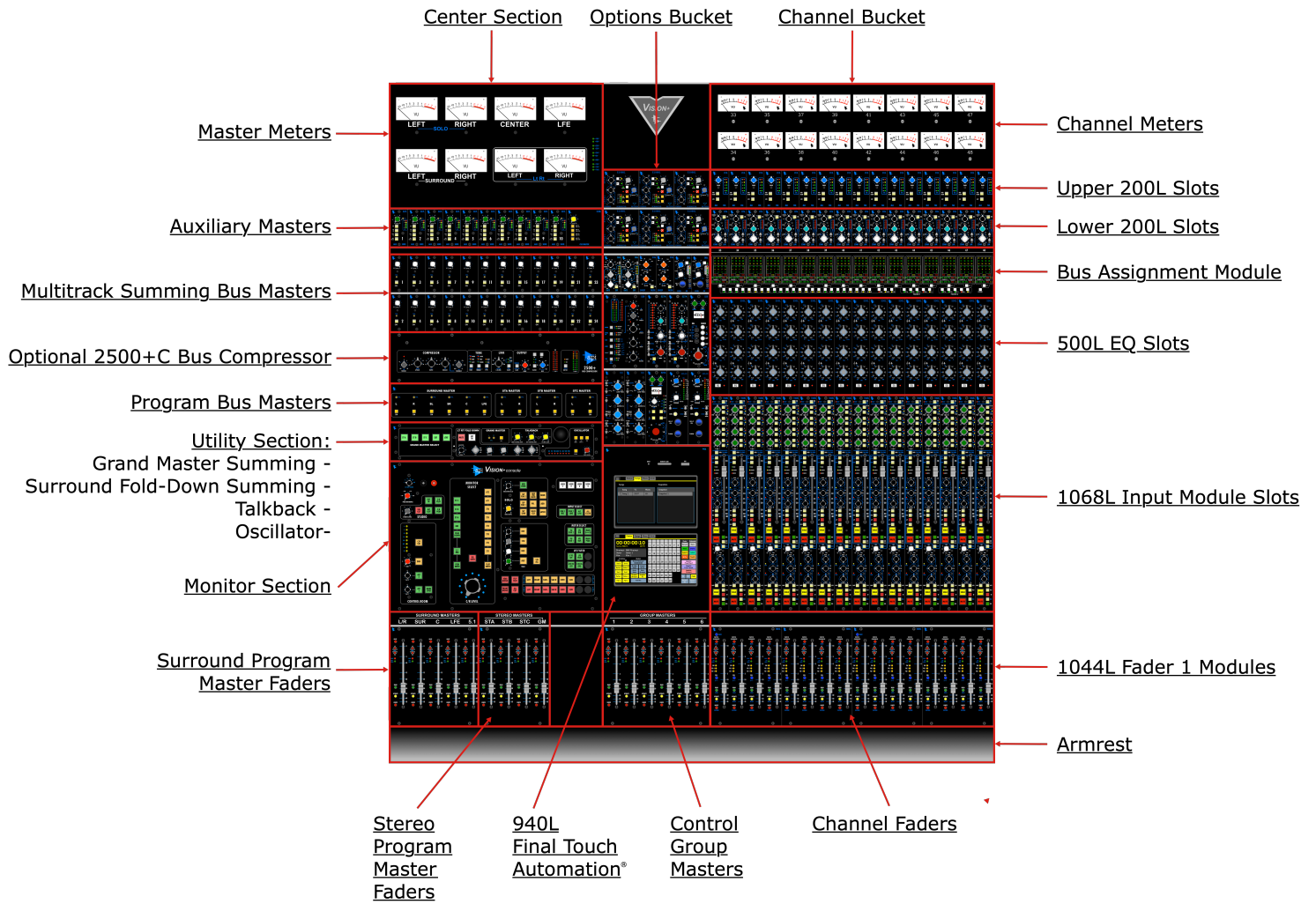

## 1.2.1 Channel Buckets

The minimum frame size for a Vison+ console is three (3) channel buckets, supporting up to 48 channels. Vison+ consoles can be built with up to six channel buckets and support up to 96 channels.

Each channel bucket can support up to sixteen (16) fully-configurable channels.

There are seven sections in each channel, five of which are user configurable.

From top to bottom, the channel sections are arranged in the following order:

- Meter bridge
- Upper 200L Slot
- Lower 200L Slot
- Bus Assignment Module
- 500L EQ Slot
- 1068L Input Module Slot
- 1044L Fader 1 Modules

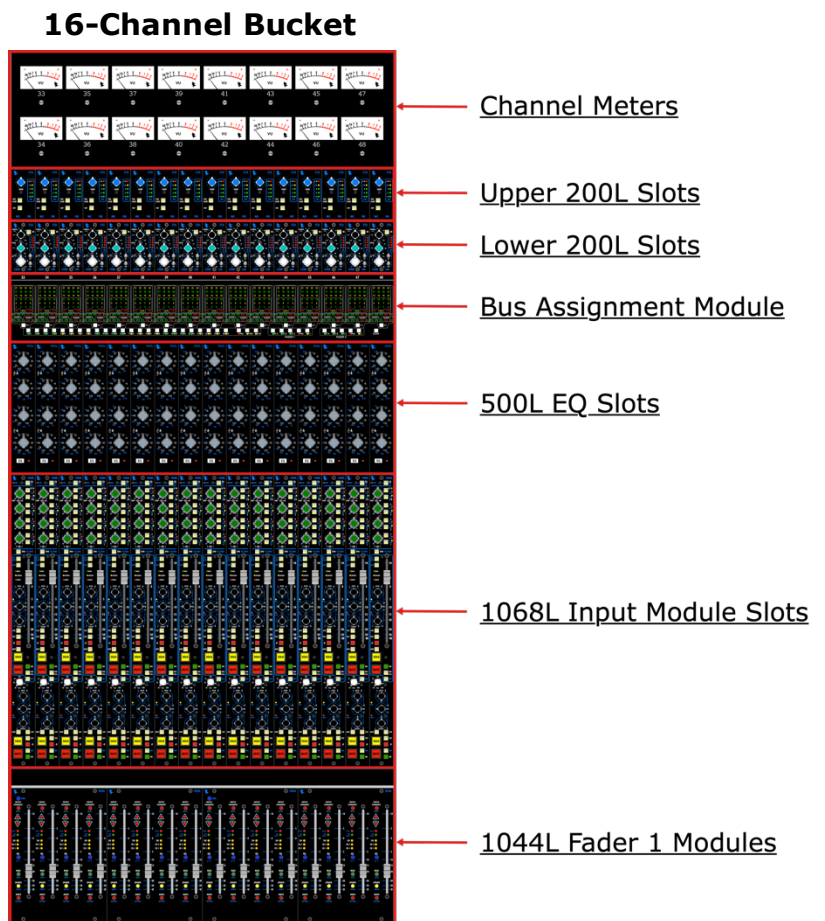

The input module slots can only be equipped with 1068L input modules.

The Fader 1 section can only be equipped with four-channel 1044L Fader 1 fader modules.

### 1.2.1.1 Upper 200L Slots

In the standard implementation, the upper 200L slot is used for channel input preamplification and the lower 200L slot is used for additional signal processing.

*NOTE: This section of the manual addresses the standard implementation of the upper and lower 200L slot functions and routing as described above. Alternate signal paths can be discussed at the time of console specification.*

In the standard implementation, the upper slot is fitted with an API 212L Microphone Preamplifier or API 205L Direct Input to serve as a channel preamp. Thus the MIC TIE-LINE patch points are fully-normalled to the MIC PREAMP INPUT path points. The output of this preamp is internally routed to feed the 1068L input module "MIC" input via the patch bay. Accordingly, MIC PREAMP OUTPUT half-normalled to FADER 2/ MIC PATH INPUT and is the default input for the Fader 2 audio path. Engaging the **MIC** switch on the 1068L input module will route the output of the upper 200L slot preamp to the input of the Fader 1 audio path. Engaging the **LINE** switch will replace the output of the preamp with the line input that is half-normalled from the MULTITRACK OUTPUT patch points.

### 1.2.1.2 Lower 200L Slots

In the standard implementation, the upper 200L slot is used for channel input preamplification and the lower 200L slot is used for additional signal processing.

The Lower 200L slot may be fitted with the following API 200 Series modules:

- 215L Sweep Filter
- 225L Compressor/Limiter
- 235L Gate/Expander

In a typical implementation, the lower slot is fitted with an API 225L Compressor/Limiter to provides dynamics processing to the channel. This slot is normalled to the MIC PATH (Fader 2) by default and its input is feed from the MIC PREAMP OUTPUT. Thus, the MIC PREAMP OUTPUT is half-normalled to the DYNAMICS INPUT patch points. The output of this lower 200L slot is internally routed to feed the 500L EQ slot. Accordingly, the DYNAMICS OUTPUT patch points are half-normalled to EQ INPUT patch points. Engaging the **DYN TO FDR1** switch on the 1068L input module will route the lower 200L slot to the LINE PATH (Fader 1).

### 1.2.1.3 500L EQ Slot

There is one (1) 500L slot for each channel designed to accommodate the channel equalizer. The 500L Slot can be equipped only with the API 500L Series modules. There are three choices of equalizer modules:

- 550AL 3-band semi-parametric EQ
- 550L 4-band semi-parametric EQ
- 560L 10-band graphic EQ

By default the 500L EQ slot is normalled to the Fader 1 audio path, but can be routed to the Fader 2 path by engaging the **EQ FDR2** function. The 500L EQ slot can be bypassed completely by engaging the **EQ BYP** switch. The routing for the 500L EQ slot can be assigned, stored, and recalled using the routing and snapshot systems and the **EQ BYP** switch may be controlled via automation.

*NOTE: Standard 500 Series modules will not fit in the 500L slot.*

### 1.2.1.4 1068L Input Module

The 1068 input module integrates the other sections of the channel strip into a comprehensive dual-path recording and mixing audio system. The 1068L input module provides the following functions:

- MIC PATH or LINE PATH input selection for both paths
- **ALT LINE** assigns the ALT MULTITRACK OUTPUT as the MIC PATH input
- Fader 1 output to Fader 2 input routing
- Phase reverse (polarity inverter) for both paths
- High-pass filters for both paths
- Insert send and return for both paths
- Peak indicator for both paths
- Automated moving faders in both paths
- Mutes for both paths
- Solo controls for both paths
- Stereo and surround panning for both paths
- Ten auxiliary sends (2 stereo, 6 mono) with comprehensive routing
- Direct output assignment

### 1.2.1.5 1044L Fader 1 Module

The 1044L fader module provides the Fader 1 automated moving fader in banks of four faders.

### 1.2.1.6 Channel VU Meter

The meter bridge is equipped with a routable VU meter for each channel. The VU meter can display Fader 1 or Fader 2 input, direct output, or multitrack summing bus levels.

## 1.2.2 Center Section

The *Vision+* center section contains the stereo and surround program bus masters, stereo and surround program master faders, stereo grand master summing, surround fold-down summing, multitrack summing bus masters, auxiliary bus masters, monitor control, a talkback preamp and microphone, talkback routing, and a routable test-tone oscillator.

Large VU meters are provided to indicate the level of the selected monitor source in the meter bridge. LED power supply indicators are also located in the meter bridge.

Four **USER** switches provide contact closures for user options.

An optional API 2500+C Bus Compressor can also be included and routable via the patch bay.

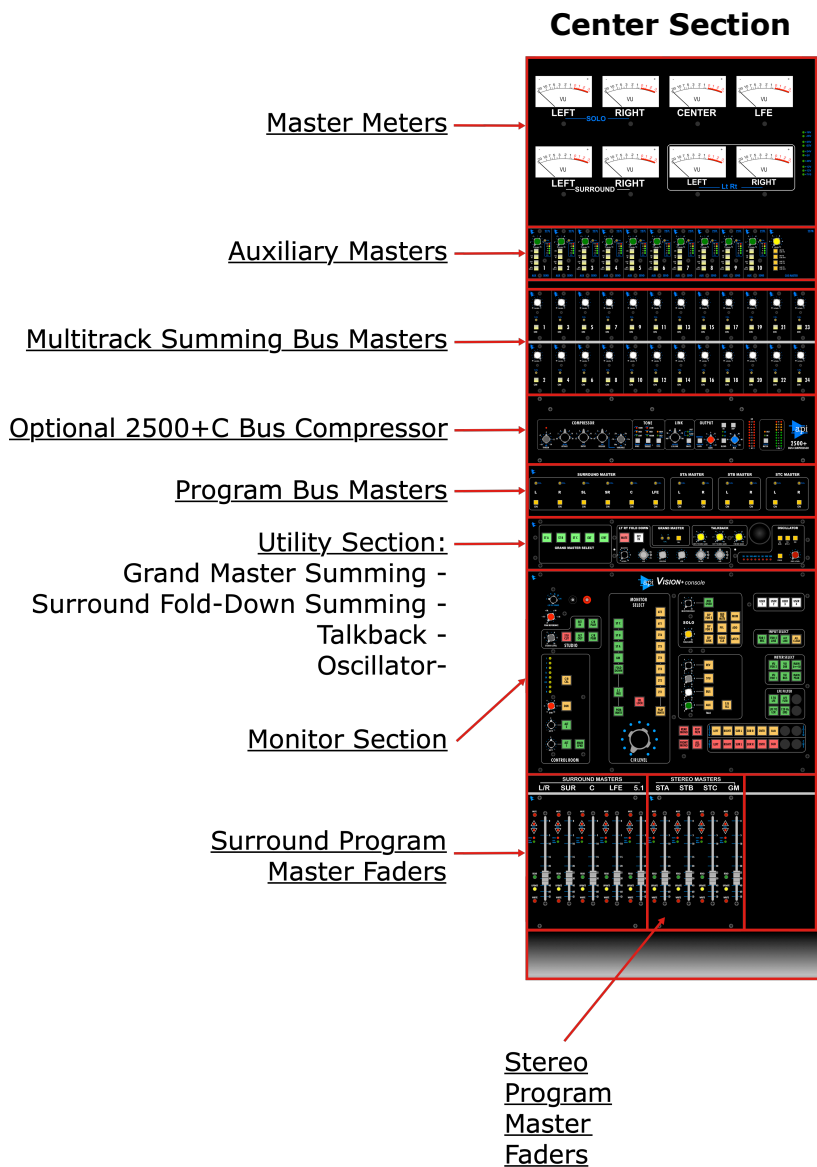

## 1.2.3 Options Bucket

An options bucket is located next to the center section and provides two (2) 200L rows for up to three (3) E1068L effects return modules or up to six (6) 200L signal processing modules per row. A third row of 200L slots is provided for up to six (6) additional 200L signal processing modules per row. Two (2) rows of standard 500 slots provide support up to 10 standard 500 Series modules. The interfacing for all options bucket modules is available in the patch bay.

The options bucket frame section also houses the *Vision+* emblem, 940L *Final Touch Automation*® control module, and control group master faders.

The options bucket can be fitted with the following 200L and standard 500 modules:

- E1068L Stereo/Surround Effects Return
- 205L Direct Input
- 212L Microphone Preamplifier
- 215L Sweep Filter
- 225L Compressor/Limiter
- 235L Gate/Expander
- 550A 3-band Semi-parametric EQ
- 550b 4-band Semi-parametric EQ
- 560 10-band Graphic EQ
- 525 Re-Issue Compressor
- 525A Compressor (w/ variable attack)
- 527A Compressor Limiter

The 500 slots in the options bucket are standard VPR Alliance 500 Series slots, so any 500 Series module that is VPR compliant may be installed.

*NOTE: Installation of any non-VPR Alliance compliant modules may void warranty coverage.*

Any combination of these modules may be installed.

The options bucket for each *Vision+* console is equipped and interfaced as specified by the owner and is therefore unique. Refer to engineering staff and documentation for the specifics of each console.

Please refer to the API website for further information. <https://apiaudio.com/api-500-200-series>

### Options Bucket

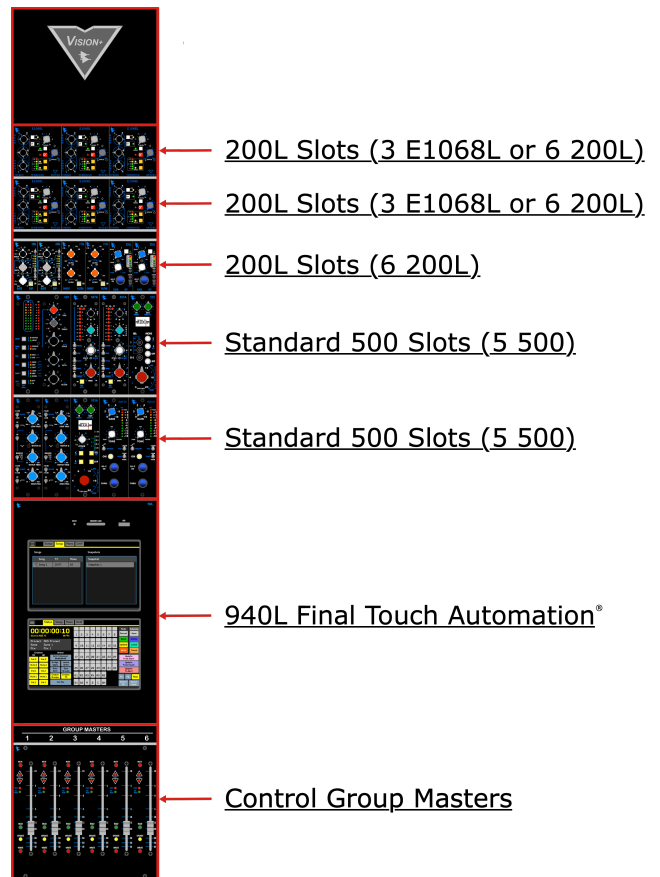

### 1.2.3.1 Options Bucket Patch Points

The patch points for 200L and 500 modules in the options bucket appear in the system patch bay. Because most consoles will have a unique set of modules installed in the options bucket, the patch bay will be labeled according to this set of modules. Generic options bucket patch points are shown below.

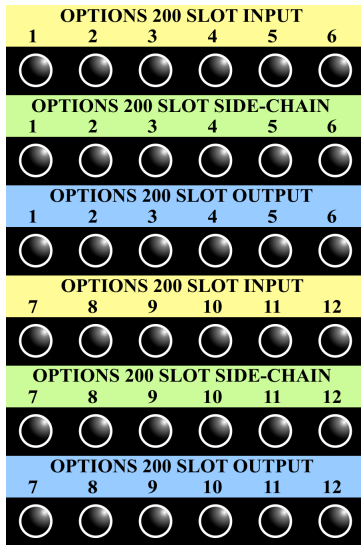

OPTIONS 200 SLOT INPUT: Options bucket 200L slot module inputs

- Half-normalled to OPTIONS 200 SLOT SIDE-CHAIN

OPTIONS 200 SLOT SIDE-CHAIN: Options bucket 200L slot module side-chain inputs

- Half-normalled from OPTIONS 200 SLOT INPUT

OPTIONS 200 SLOT OUTPUT: Options bucket 200L slot module outputs

*NOTE: Patching into the OPTIONS 200 SLOT SIDE-CHAIN will replace the OPTIONS 200 SLOT INPUT as the source for the module's detection path (side-chain input)*

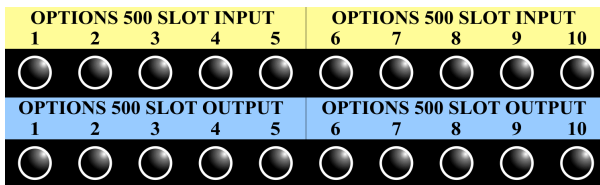

OPTIONS 500 SLOT INPUT: Options bucket 500L slot module inputs

OPTIONS 500 SLOT OUTPUT: Options bucket 500L slot module outputs

### 1.2.4 Optional Producer's Desk

An optional producers desk/DAW workstation can be ordered at the time of console specification. This option provides workspace for production personnel, digital audio workstation operation, and other applications. Accordingly, the space can be fitted with a user-supplied monitor.

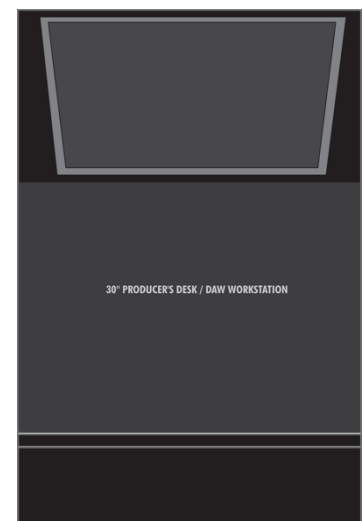



## 2.0 Channel Signal Flow

In combination, the modules installed in the upper and lower 200L slots, the 500L EQ slot, the 1068L input module, 1044L Fader 1 fader module, and channel VU meter, compose a complete input/output, dual audio path, channel-strip. The patch bay contains 20 channel-oriented patch points that tie these assets together into a versatile and comprehensive audio system for simultaneous recording and mixing of multitrack audio.

While all fully integrated, channel signal flow has four aspects to be considered:

- Front-end Signal Flow: MIC and LINE input paths: 200L slots, 500L slots, and inserts
- Patch Bay: Signal flow through the 20 channel-oriented patch points
- 1068L Module: Fader 1 and Fader 2 signal flow through the 1068L input module
- Output Assignments: Signal flow to the direct out, program buses, and multitrack summing buses

## 2.1 Dual Signal Path Channel Architecture

As mentioned above, the upper and lower 200L slots, the 500L EQ slot, the 1068L input module, 1044L Fader 1 fader module, and channel VU meter, compose a complete input/output, dual-audio-path, channel-strip. This dual-signal-path architecture provides two complete and independent audio paths in a single, inline channel-strip. These paths are organized into two input paths (MIC and LINE) and two 1068L fader paths (Fader 1 and Fader 2).

- MIC PATH:
  - Upper 200L slot: Preamplification
  - Lower 200L slot: Dynamic processing (compressor)
  - Fader 2 Insert
  - All associated patch points
  - Default source for 1068L Fader 2 input
- LINE PATH:
  - 500L EQ slot: Spectral processing (equalizer)
  - Fader 1 Insert
  - All associated patch points
  - Default source for 1068L Fader 1 input
- 1068L Fader 2 Path:
  - Fed from MIC PATH by default
  - Output assignments
  - VU meter
  - All associated patch points
- 1068L Fader 1 Path:
  - Fed from LINE PATH by default
  - 1044L Fader 1 fader module
  - Output assignments
  - VU meter
  - All associated patch points

The output of either input path, MIC or LINE, can be routed to either 1068L fader path using the Fader 2 **LINE** switch or the Fader 1 **MIC** switch. The **ALT LINE** function will replace the output of the upper 200L slot preamp with the signal from the ALT MULTITRACK OUTPUT

patch point as the source for the MIC PATH. The output of Fader 1 can also be routed to Fader 2 using the **FDR 1** switch.

The lower 200L slot is typically equipped with a 225L Compressor/Limiter and is internally normalled to the MIC PATH, which feeds the 1068L Fader 2 audio path. Similarly, the 500L EQ slot is equipped with one of three equalizers, 550L, 550AL, or 560L, and is internally normalled to the LINE PATH, which feeds the 1068L Fader 1 audio path. These modules can be rerouted to the other path using the **EQ FDR2** and **DYN FDR1** switches on the 1068L module.

In typical applications, the audio paths will be used as follows:

#### Multitrack Recording:

- The MIC PATH and 1068L Fader 2 path feed the signals from a microphone preamp, DI, or other input source to the multitrack recorder (DAW or tape machine) via direct outputs and/or the 24 multitrack summing buses
- The line input path and 1068L Fader 1 path accepts the returns from the multitrack recorder and routes them to the stereo and/or surround program buses (mix buses)

#### Stereo and Surround Mixing:

- The LINE PATH and 1068L Fader 1 path accepts the returns from the multitrack recorder and other sources and routes them to any of the three stereo program buses and/or surround program buses
- Fader 2 can carry additional multitrack returns and other sources to the program buses
- Fader 2 may alternately be used as an extra auxiliary send or LFE send, using the multitrack summing buses as outputs
- Both fader paths are fully automatable and provide stereo and surround panning

For those familiar with other inline recording consoles, in a typical session MIC PATH/Fader 2 functions as a "mic," "preamp," "input," or "channel" path (while tracking) and LINE PATH/Fader 1 functions as a "line," "multitrack return," "monitor," or "mix" path.

## 2.2 Channel Strip Components

Several sections of the console make up a complete input/output (I/O) channel:

- Channel meter
- Upper 200 Slot input processing
  - 212L Microphone Preamp -OR-
  - 205L Direct Input
- Lower 200 Slot (Signal Processing)
  - 215L High-Pass Sweep Filter -OR-
  - 225L Compressor -OR-
  - 235L Gate
- 500L Equalizer Slot
  - 550AL 3-band semi-parametric EQ -OR-
  - 550L 4-band semi-parametric EQ -OR-
  - 560L 10-band graphic EQ
- 1068L V3 Input Module
  - Input selection for both paths (**MIC** or **LINE** or **ALT LINE**)
  - EQ and dynamic processor routing
  - Phase reverse (polarity inverter) for both paths
  - Insert send and return for both paths
  - Peak Indicator for both paths
  - Fader 2
  - Filters for both paths
  - Mutes for both paths
  - Solo controls for both path
  - Fader 1 output to Fader 2 input routing
  - Stereo/surround panning for both paths
  - Ten auxiliary sends (2 stereo, 6 mono)
  - Auxiliary send routing
  - Output assignments for both paths
- 1044L Fader 1 module

# 2.3 Channel Strip Full Block Diagram

As mentioned above, the complete channel strip signal flow is made up of frame components (slots and meters), 200L, 500L, 1068L, and 1044L modules, and the channel-oriented patch points in the patch bay. The complete channel signal flow is illustrated in the diagram below:

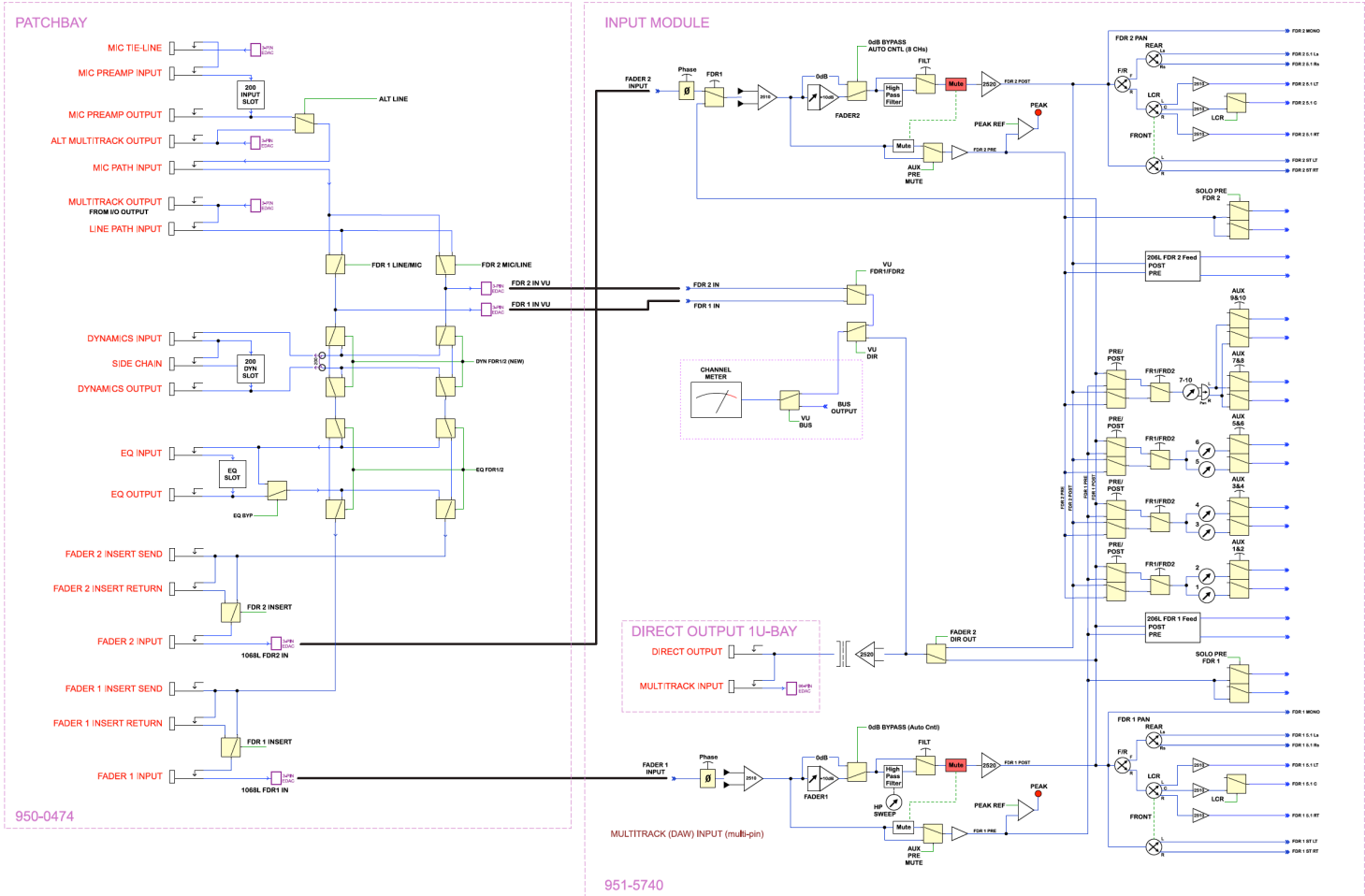

## 2.4 Channel Strip Front-End Signal Flow

The upper and lower 200L slots, the 500L EQ slot, the Fader 1 insert, Fader 2 insert, and the associate patch points make up the front-end of the channel signal flow. While integrated with the 1068L module, signals flow through these frame and patch bay components before feeding the 1068L module. In combination these components create the two input paths of the dual-channel archetecture:

- **MIC PATH:** Preamp record path, normalled to 1068L Fader 2 input
  - Upper 200L slot (preamp)
  - Lower 200L slot (dynamics)
  - Fader 2 insert (send and return)
- **LINE PATH:** Multitrack return mix path, normalled to 1068L Fader 1 input
  - 500L EQ slot (equalizer)
  - Fader 1 insert (send and return)

The input sources can be shared by both paths. The lower 200L module (dynamics), and 500L EQ module can be swapped between paths.

### 2.4.1 Mic Path Signal Flow

As mentioned above, the MIC PATH provides signal flow for delivering the signal from a microphone or instrument to the multitrack recorder. In a typical configuration, microphone/instrument signals flow from the MIC TIE-LINE patch points to the upper 200L preamp module via full-normal to the MIC PREAMP INPUT patch points. The MIC PREAMP OUTPUT flows to the MIC PATH INPUTs and audio flows downward through the lower 200L module (dynamic processing), through the Fader 2 insert send and return patch points to the 1068L Fader 2 audio path via patch bay half-normals.

The upper 200L module is typically fitted with either 212L Microphone Preamp or 205L Direct Input module.

The lower 200L module is typically fitted with a 225L Compressor/Limiter module to provide channel dynamics processing. Accordingly, the associated patch points are labeled DYNAMICS INPUT, SIDE CHAIN, and DYNAMICS OUTPUT. Alternately, some lower 200L slots in some consoles may be fitted with 235L Gate/Expander, or 215L Sweep Filter module. The lower 200L slot is part of the MIC PATH by default, but can be assigned to the LINE PATH as needed. The output of the lower 200L slot feeds the Fader 2 INSERT SEND patch point by default.

The Fader 2 INSERT SEND patch points are fed from the DYNAMICS OUTPUT patch points. The FADER 2 INSERT SEND patch points are always active and the signal at the FADER 2 INSERT RETURN patch point is active when the Fader 2 **INS** switch engaged. The Fader 2 insert is the last section of the MIC PATH and feeds the 1068L Fader 2 input.

### 2.4.2 Line Path Signal Flow

As also previously mentioned, the LINE PATH provides signal flow for delivering the signals from the multitrack recorder to the stereo and/or surround program buses for mixing. Audio flows from the MULTITRACK OUT tie-lines to the LINE PATH INPUT patch points, through the 500L EQ module via the EQ INPUT patch points. The Fader 1 INSERT SEND patch points are

fed from the EQ OUTPUT patch points. The FADER 1 INSERT SEND patch points are always active and the signal at the FADER 1 INSERT RETURN patch point is active when the Fader 1 **INS** switch engaged. The Fader 1 insert is the last section of the LINE PATH and feeds the 1068L Fader 1 input.

The 500L equalizer slot provides spectral processing and may be fitted with a 550AL, 550L, or 560L equalizer module. It is part of the LINE PATH by default, but can be assigned to the MIC PATH as needed. The output of the 500L EQ slot feeds the Fader 1 INSERT SEND patch point by default.

### 2.4.3 Front-End Signal Flow

The front-end MIC PATH and LINE PATH signal flow is illustrated in the diagram below:

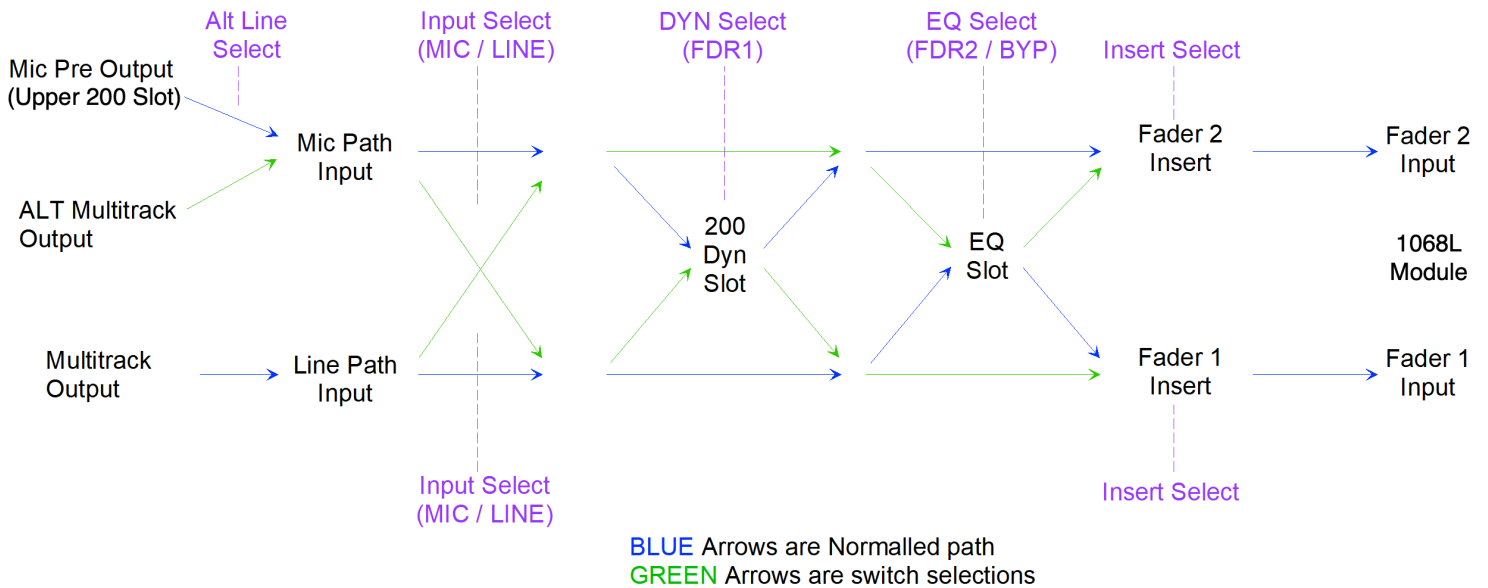

# 2.5 Channel Strip Patch Points

Eighteen (18) of the twenty (20) channel-oriented patch points support the MIC PATH and LINE PATH signal flows. The diagram below illustrates how these channel patch points, 200L slots, 500L EQ slot, and Fader 1 and Fader 2 inserts are all integrated in the front-end signal flow.

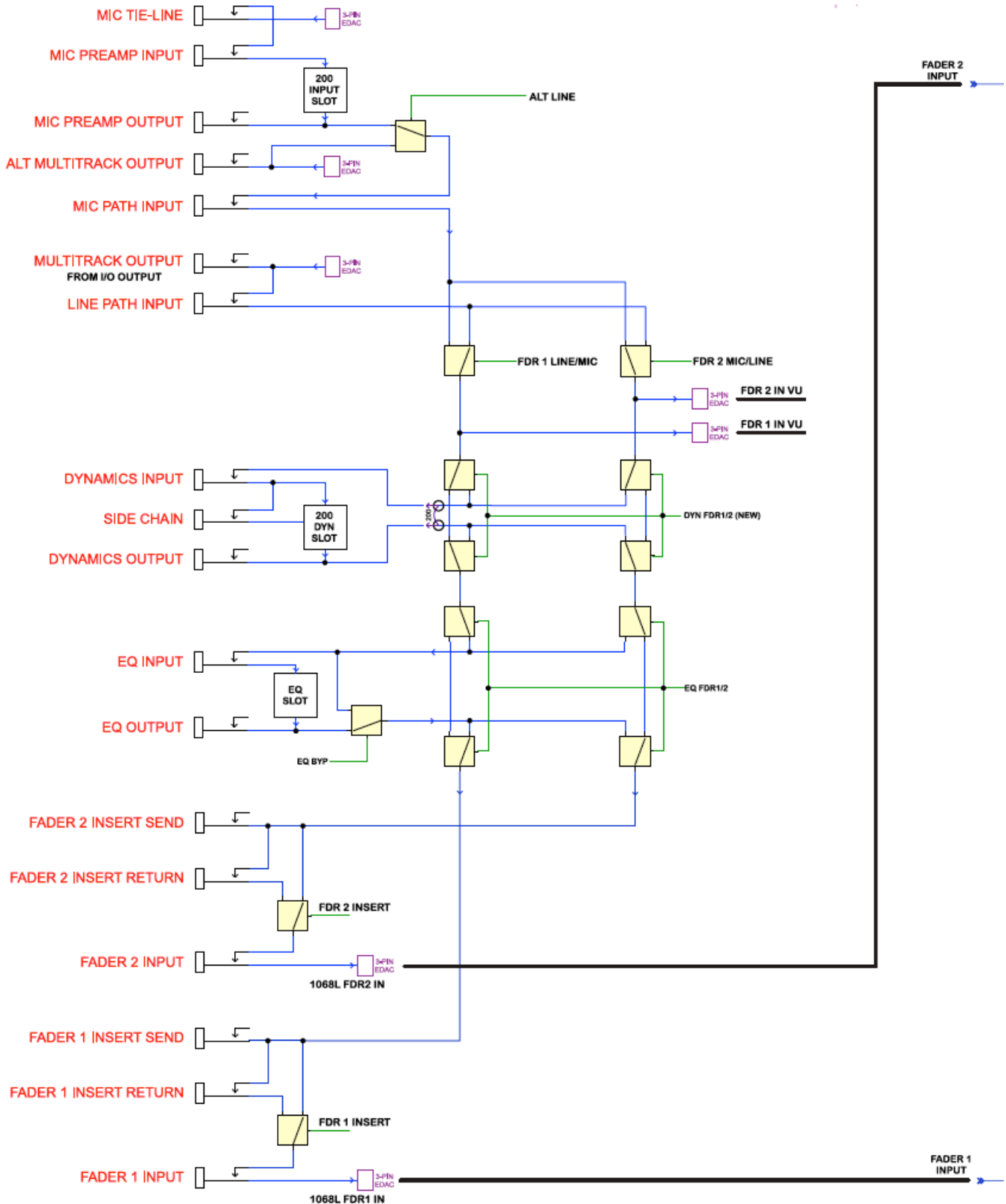

## 2.6 1068L Input Module Signal Flow

The 1068L Input Module is the heart of the channel-strip. As the *Vision+* console has evolved over time, three different versions of the 1068L input module have been produced: the original 1068L (V1), the V2 version, and the most recent V3 version with enhanced features for *Vision+* consoles.

*NOTE: This manual is based on the V3 1068L Input Module. Original (V1) and V2 versions of the input modules will be address via notes and separate sections.*

The design all three versions of the 1068L input modules provide two fully-featured audio paths for multitrack recording (one for routing microphones to a multitrack: Fader 2 and one for mixing the multitrack return: Fader 1) or two complete audio paths with automation and stereo/surround panning for mixing. A choice of inputs, a comprehensive set of channel patch points, and extensive output options combine with the other channel features to provide great flexibility.

All 1068L input modules fully integrate with the API *Final Touch Automation*<sup>®</sup> system for easy project management, snapshots, and moving fader/switch automation. *Final Touch Automation*<sup>®</sup> includes channel routing/settings assignment function that can be used to setup, store, and recall snapshots of input/output routing, fader positions, switch settings, auxiliary send routing, and global features for one or more channels. *Final Touch Automation*<sup>®</sup> also provides a comprehensive mixing automation system that records and plays back moves made to both channel faders, mutes, inserts, as well as the EQ bypass, and auxiliary send on/off switches.

To simplify channel signal flow, the 1068L V3 section of the full block diagram is broken down into two smaller sections that follow.

## 2.6.1 1068L Fader 1 Signal Flow

A simplified 1068L Fader 1 signal flow is illustrated in the diagram below:

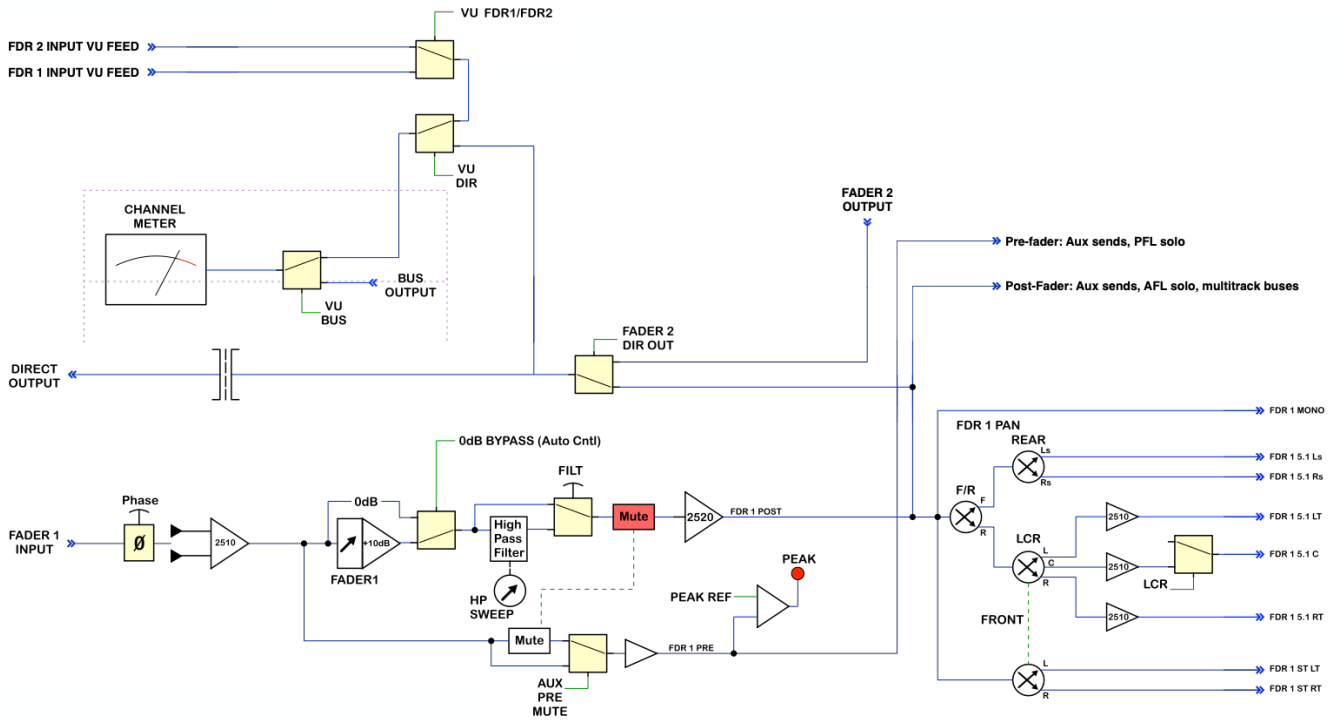

The 1044L fader module is integrated with the 1068L module to provide an automated fader for the Fader 1 audio path. It is typically used to feed the assigned program buses.

## 2.6.2 1068L Fader 2 Signal Flow

A simplified 1068L V3 Fader 2 signal flow is illustrated in the diagram below:

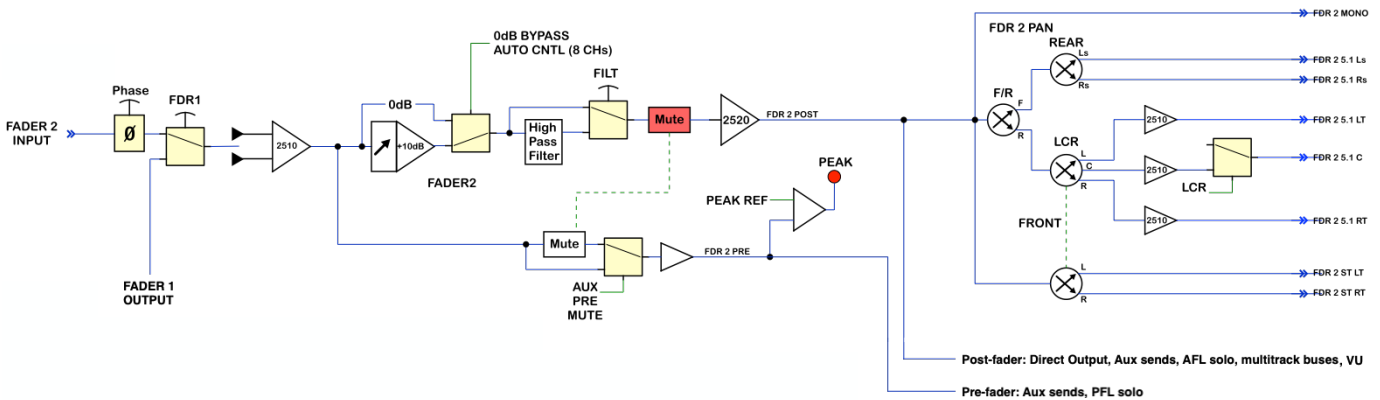

The outputs of 1068L input module feed the channel assignment module and all channel strip components are interfaced via the channel patch bay.

*NOTE: Channel auxiliary send and solo signal flow is not included in this section, but will be covered later in this manual.*

## 2.7 Channel Input Path Source Selection

There are two primary choices of input sources for each input path:

- **MIC PATH:** (mic preamp output): This is the output of the installed preamp in the upper 200L slot via MIC PRE OUTPUT to MIC PATH INPUT patch bay half-normal. There are two modules available to serve as a preamp:
  - 212L Microphone Preamplifier
  - 205L Direct Input
- **LINE PATH:** (primary multitrack output): This is the output from the multitrack recorder interfaced with the console via MULTITRACK OUTPUT to LINE PATH INPUT patch bay half-normal

To increase flexibility, an additional alternate multitrack output is provided:

- **ALT LINE:** Replaces the MIC PREAMP OUTPUT with the ALT MULTITRACK OUTPUT as the MIC PATH input source and routes patch point to the either audio path as follows:
  - Fader 2: Replaces MIC PREAMP as the Fader 2 input source when engaged
  - Fader 1: Replaces LINE PATH as the Fader 1 input source when engaged, along with the **MIC** switch

Additionally, the Fader 2 can receive the output of Fader 1 as its input if the **FDR1** switch is engaged. This topic will be cover in more detail later in this manual.

The **INPUT SELECT** switches in the center section (**FDR1 MIC, FDR2 LINE**), the Fader 1 **MIC** switch, and the Fader 2 **LINE** switch will determine which input source is routed to each 1068L audio path. The default input selection (no input selection switches engaged) for each path is as follows:

- Fader 1: LINE PATH: MULTITRACK OUTPUT to LINE PATH INPUT patch bay normal
- Fader 2: MIC PATH: MIC PRE OUTPUT to MIC PATH INPUT patch bay normal

Pressing the input selection switches selects the alternate source available, either **MIC** for Fader 1 or **LINE** for Fader 2.

Both fader paths may be fed from the same source.

*NOTE: The **ALT LINE** function is only available on 1068L V3 input modules and V3 consoles. This feature is not available on orginal or 1068L V2 equipped consoles.*

## 2.8 Channel Signal Processing

**Lower 200L Slot:** The lower 200L slot is optionally fitted with an additional signal processor:

- The lower 200L slot may be fitted with the following signal processing modules:
  - 215L Sweep Filter
  - 225L Compressor/Limiter (typically installed to provide dynamics processing)
  - 235L Expander/Gate

**500L Equalizer Slot:** A dedicated slot is provided for a 500L series equalizer

- The equalizer is normally assigned to Fader 1
- The equalizer can be assigned to Fader 2 by engaging the **EQ FDR2** switch
- The equalizer may be bypassed by engaging the **EQ BYP** switch

- The 500L Slot may be fitted with the one of the following Equalizers
  - 550AL 3-band semi-parametric EQ
  - 550L 4-band semi-parametric EQ
  - 560L 10-band graphic EQ

**1068L:** Fader 1 and Fader 2 audio paths have the following features:

- Independent, balanced patch bay INSERT SEND and INSERT RETURN patch points with automatable **INS** switches on both paths
- Phase reverse (polarity inverter)
- High-pass filter
  - Fader 1 has a 40-600Hz sweep filter
  - Fader 2 has a 50Hz fixed filter
  - Both filters have a 12dB/octave slope
- Automatable moving fader
- Automatable **MUTE** switches
- Available 0dB fader bypass
- Switchable routing to six (6) mono and two (2) stereo pre/post switchable auxiliary sends (in pairs) with automatable **ON/off** switches
- LED peak indicator
- Routable channel VU meter
- Solo activation

*NOTE: A -6dB **TAPE PAD** and input **TRIM** pot are provided on original and 1068L V2 input modules. These features are not provided on the 1068L V3 modules.*

## 2.9 Channel Output Assignments

Fader 1 and Fader 2 paths have complete access to all output assignment possibilities as follows:

- Insert send
- Direct output
- Stereo/surround panning
- Multitrack summing buses 1-24
- Surround program bus
- Stereo program buses A, B, and C
- Auxiliary sends 1-10

**Direct Output:** Each channel is equipped with one direct output

- Typical half-normal patch bay connection: DIRECT OUT to MULTITRACK INPUT
- Direct output is always active and does not replace the Multitrack Bus outputs
- The direct output is fed by Fader 1 by default
- Fader 2 feeds the direct output only when the **DIR FDR2** switch is engaged
- Only one audio path (Fader 1 or Fader 2) can feed the direct output

**Multitrack Summing Buses:** Twenty-four (24) multitrack summing buses feed the “Active Combining Amplifier” (BUS OUTPUT 1-24) outputs

- There is a **LEVEL** pot, **ON/off** switch, and a calibration trim pot for each multitrack summing bus output
- Typical half-normal patch bay connection: BUS OUT to MULTITRACK IN
- Multitrack summing buses are normally fed from Fader 1
- Only one audio path (Fader 1 or Fader 2) can feed the multitrack summing buses

**Stereo/Surround Panning:** Full stereo and surround panning is provided for both audio paths (Fader 1 and Fader 2)

- Pan-pots can be independently engaged in either or both audio paths
- The pan-pots in both paths feed the stereo and/or surround program buses as assigned
- The **FRONT** panners in both paths are dual pan-pots controlled by one knob. When assigned to both stereo and surround program buses, one pot feeds the L-R stereo program buses and the other feeds the L-C-R front surround buses, allowing simultaneous stereo and surround mixing

**Stereo Program Buses:** Three independent stereo program buses, A, B, & C feed the "Active Combining Amplifier" (STEREO ACA) outputs

- There is an **ON**/off switch and a calibration trim pot for each program bus output
- The outputs of the three stereo program buses can be summed to a single GRAND MASTER stereo output (to facilitate easy sub-mixing and parallel processing)
- Both paths (Fader 1 and Fader 2) can be independently assigned to the all 3 stereo program buses simultaneously in any combination
- Simultaneous assignment from both paths to all program buses allows the simultaneous output of a surround and three stereo mixes

**Surround Program Bus:** A 5-channel surround program bus feed the "Active Combining Amplifier" (SURROUND ACA) outputs

- There is an **ON**/off switch and a calibration trim pot for each program bus output
- Assignments can be made to the surround program bus (L-R, SI-Sr, C, LFE)
- A Low Frequency Effect (LFE) channel can be created using a auxiliary send or the Fader 2 audio path via a multitrack summing bus
- Both paths can be assigned to the surround program bus simultaneously

**Auxiliary Sends (Aux Sends):** Both paths can feed 2 stereo and/or 6 mono auxiliary sends

- Sends are organized in pairs, 1-2, 3-4, etc.
- Aux sends 1-6 are mono
- Aux sends 7-8 and 9-10 are stereo
- Either path can feed any or all pairs of sends
- Only one path can feed each pair of sends at a time
- An auxiliary send can be routed pre or post the fader of the assigned path
- Aux sends 9-10 can be routed to multitrack summing buses 1-8

**Channel Insert Sends:** Both paths are equipped with an independent automatable insert

- INSERT SEND patch points always carried the signal from its audio path
- INSERT RETURN patch point are inserted in the audio path signal flow when the **INS** switch is engaged

# 3.0 Channel Strip Controls

## 3.1 Input Selectors

The input selection for both audio paths (Fader 1 and Fader 2) can be assigned globally across the entire console or locally on individual 1068L input modules. There are two input options available to each audio path:

- **MIC**: Output of the MIC PATH (upper/lower 200L slots and Fader 2 insert)
- **LINE**: Output of the LINE PATH (multitrack output, 500L EQ slot, and Fader 1 insert)

Both input sources are routed to the 1068L input module via the channel patch bay as follows:

- MIC PREAMP OUTPUT is half-normaled to MIC PATH INPUT
- MULTITRACK OUTPUT is half-normaled to LINE PATH INPUT

Accordingly, the output of the MIC PATH (preamp installed in the upper 200L slot, lower 200L slot, and Fader 2 insert) is the default input to the 1068L Fader 2 audio path. The output of the LINE PATH (multitrack return, 500L EQ slot, and Fader 1 insert) is the default input to the 1068L Fader 1 audio path. These default input sources can be swapped globally using the **INPUT SELECT** controls in the center section or on individual channels using the **MIC** and **LINE** switches on the 1068L input modules.

To increase flexibility, an additional alternate multitrack output is provided 1068L V3 input module. **ALT LINE** replaces the PREAMP OUTPUT as the MIC PATH input source and routes the ALT MULTITRACK OUTPUT patch point to the either audio path as follows:

- **Fader 2**: Replaces MIC PATH as the default Fader 2 input source when engaged
- **Fader 1**: Replaces MIC PATH as the Fader 1 input source when engaged, along with the **MIC** switch

### 3.1.1 Global Input Selectors (INPUT SELECT)

The **INPUT SELECT** section of the center section provides global switching between the primary input sources (MIC and LINE) for the Fader 1 and Fader 2 audio paths.

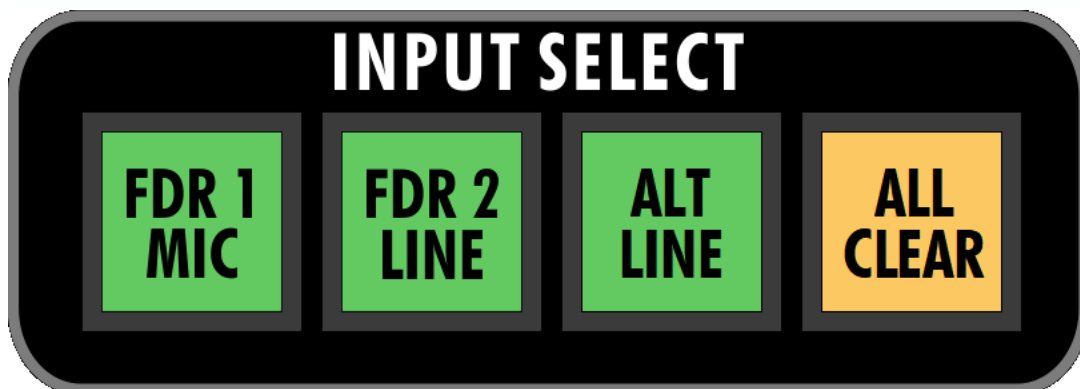

**FDR 1 MIC**: Selects MIC PATH as the Fader 1 source for all channels

- Replaces LINE as the Fader 1 input
- Momentarily illuminates in green when pressed



**FDR 2 LINE:** Selects LINE PATH as the Fader 2 source for all channels

- Replaces MIC as the Fader 2 input
- Momentarily illuminates in green when pressed



**ALT LINE:** Selects ALT LINE as the MIC PATH source all channels

- Replaces MIC
- Momentarily illuminates in green when pressed



**ALL CLEAR:** Resets the input selection to the locally defined state:

- Fader 1 = LINE PATH, Fader 2 = MIC PATH without any channel input selections engaged
- Momentarily illuminates in yellow when pressed

*NOTE: The Fader 1, Fader 2, and **ALT LINE** input selections may be set, stored, and recalled by making assignments and snapshots using the routing and snapshot systems.*

### 3.1.2 1068L V3 Input Selectors

As noted previously, the default inputs for the Fader 1 and Fader 2 paths are as follows:

- Fader 1: LINE PATH input (MULTITRACK OUTPUT patch points)
- Fader 2: MIC PATH input (PREAMP OUTPUT patch points from the Upper 200L slot)

These inputs can be changed on individual channels using the following switches on the 1068L V3 input module:



**MIC:** Routes the MIC PATH input (PREAMP OUT) to the Fader 1 input

- Replaces LINE PATH as the Fader 1 input
- Illuminates when engaged



**LINE:** Routes the LINE PATH input (MULTITRACK OUT) to the Fader 2 input

- Replaces the MIC PATH or ALT LINE source as the Fader 2 input
- Illuminates when engaged

To increase routing flexibility, both the Fader 1 and Fader 2 audio paths can also receive the signal from an alternate multitrack (ALT MULTITRACK OUTPUT) as their input source.



**ALT LINE:** Replaces the MIC PREAMP OUTPUT with the ALT MULTITRACK OUTPUT as the MIC PATH input source and routes patch point to the either audio path as follows:

- Fader 2: Replaces MIC PREAMP as the Fader 2 input source when engaged
- Fader 1: Replaces LINE PATH as the Fader 1 input source when engaged, along with the **MIC** switch
- Illuminates when engaged

*NOTE: There are no patch bay normals that feed the ALT MULTITRACK OUTPUT patch points. However, the signal is received from the 3-pin EDAC connectors associated with each point. Alternately, patching from a line-level source into these point will replace the alternate multitrack source.*

For additional routing flexibility, the Fader 2 audio path can also receive the Fader 1 output as its input source.



**FDR1:** Internally routes the post-fader output from the Fader 1 audio path to the Fader 2 input

- Replaces the otherwise selected source as the Fader 2 input
- Illuminates when engaged

## 3.2 Channel Preamp Modules

The upper 200L slot is the first section of a channel strip and provides the microphone or instrument preamplification options for the channel. There are two (2) preamplifier modules available for the channel input:

- 212L Microphone Preamplifier
- 205L Direct Input

Additional 212L and 205L preamplifier modules may be installed in the options bucket.

The following standard 500 Series module may also be installed in the options bucket to provide additional preamplification options: 312 Mic Preamp, 512C Mic/Line Preamp, 512V Mic/Line Preamp, and/or 505 DI Direct Input.

### 3.2.1 Upper 200L Slot Channel Strip Integration

Regardless of the module installed in the upper 200L slot, it is interfaced with the channel strip as follows:

- The MIC TIE-LINE patch point is full-normalled to the MIC PREAMP INPUT patch point
- The MIC PREAMP INPUT patch point feeds the input of the upper 200L slot
- The output of the upper 200L slot feeds the MIC PREAMP OUTPUT patch point
- The MIC PREAMP OUTPUT patch point is half-normalled to the MIC PATH INPUT patch point as the default input to the Fader 2 audio path
- MIC PREAMP OUTPUT patch point will feed the Fader 1 input if the **MIC** switch is engaged
- The ALT MULTITRACK OUTPUT patch point will replace the PREAMP OUTPUT as the MIC PATH input source and will feed the Fader 1 input if the **MIC** and **ALT LINE** switches are engaged

## 3.2.2 212L Microphone Preamp

Typical *Vision+* consoles will have 212L Microphone Preamp modules installed in the channel upper 200L slot to amplify signals from balanced low-impedance microphones.

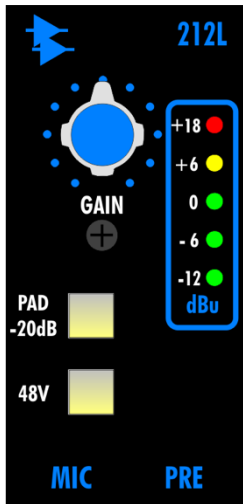

### Features:

- Wide range gain control
- -20dB pad
- 48v phantom power
- API microphone input transformer
- LED level meter
- Uses API 2520 Op-Amp
- Transformer coupled inputs & outputs to +28dBu
- Discrete circuit design

Refer to the 212L website for more information:

<https://apiaudio.com/product/212l-mic-pre/>

The controls for the 212L MIC PRE function as follows:



**GAIN:** Sets the preamplifier gain

- 55dB gain range



**PAD -20dB:** Inserts a -20dB pad at the microphone input

- Illuminates when engaged



**48V:** Provides 48 volt phantom power to the MIC PREAMP INPUT patch point

- Illuminates when engaged

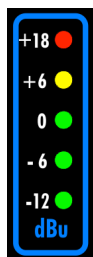

**dBu (meter):** 5-segment multi-color LED meter

- Indicates 212L output level
- -12 to +18dBu

*NOTE: The switches on this module are not part of the automation, routing, or snapshot systems.*

### 3.2.3 205L Direct Input

Some *Vision+* consoles might have 205L Direct Input modules installed in some upper 200L slots to amplify signals from unbalanced, high-impedance instruments.

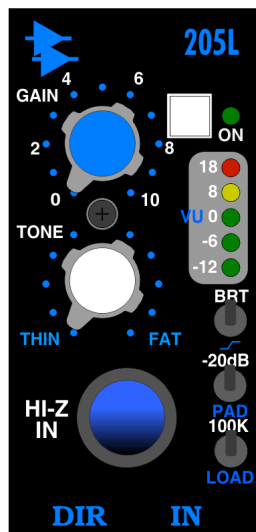

#### Features:

- High-impedance (Hi-Z) input
- Wide range gain control
- Thin-Fat tone control
- Bright switch boosts the presence
- -20dB pad
- 100K load control changes input impedance
- LED VU level meter
- Transformer coupled output to +28dBu
- Discrete circuit design

Refer to the 205L website for more information:  
<https://apiaudio.com/product/205l-direct-input/>

The controls for the 205L Direct Input function as follows:



**ON** (On/off switch): Activates the module

- A hard-wired bypass is active when **ON** is not engaged
- Illuminates in green when engaged



**GAIN**: Sets the preamplifier gain

- -40 to +20 dB

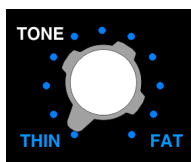

**TONE**: Adjusts the tonal characteristics of the amplified signal

- Useful to reduce "muddiness"
- **THIN**: - 12 at 150 Hz
- **FAT**: Flat (+/- 0 dB)



**BRT** (Bright): Activates a presence boost

- +6dB at 8kHz



**-20dB PAD**: Inserts a -20dB pad at the instrument input



**100K LOAD**: Engages a 100 KOhm load across the input

- Changes the tone of the pickup and tends to darken the high frequency content



**Hi-Z IN** (High Impedance ¼" Input Jack): Instrument input jack

- Illuminated in blue

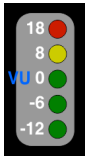

**VU** (Meter): 5-segment, multi-color LED meter

- Indicates 212L output level
- -12 to +18dBu

*NOTE: The switches on this module are not part of the automation, routing, or snapshot systems.*

## 3.3 Channel Signal Processing Modules

The lower 200L slot is the second section of a channel strip and provides additional signal processing options for the channel. There are three (3) 200L signal processing modules available for the channel strip:

- 225L Compressor/Limiter
- 215L Sweep Filter
- 235L Gate/Expander

Additional 215L, 225L, and 235L signal processing modules may be installed in the options bucket.

The following standard 500 Series module may also be installed in the options bucket to provide additional preamplification options: 525 Compressor, 525A FET Compressor, 527A Compressor/Limiter, and/or 529 Stereo Compressor.

### 3.3.1 Lower 200L Slot Channel Integration

Regardless of the module installed in the lower 200L slot, it is interfaced with the channel strip as follows:

- The lower 200L slot is routed to/from the MIC PATH and is associated with the Fader 2 audio path by default
- The lower 200L slot will be routed to/from the LINE PATH and Fader 1 if the **DYN TO FDR1** switch is engaged.
- The input of lower 200L slot is fed from the selected MIC PATH input (MIC PREAMP OUT or ALT MULTITRACK OUTPUT) via the DYNAMICS INPUT patch point
- The SIDE CHAIN patch point feeds the lower 200L slot side chain input
- The output of the lower 200L slot feeds the FADER 2 INSERT SEND patch point via the DYNAMICS OUTPUT patch point
- The FADER 2 INSERT SEND is half-normalled to the FADER 2 INSERT RETURN patch point and feeds the Fader 2 input of the 1068L input module
- If the Fader 2 **INS** switch is engaged the signal present at the FADER 2 INSERT RETURN patch point will feed the Fader 2 input of the 1068L input module

## 3.3.2 225L Compressor/Limiter

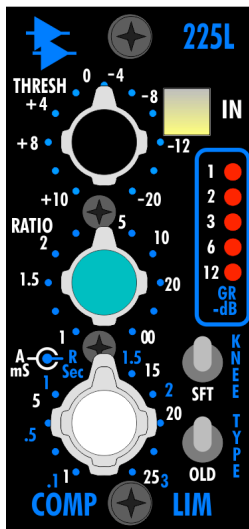

### Features:

- Threshold control from -20 to +10 dBu
- Variable compression ratio from 0 to infinity
- Fully variable attack times from 1 to 25ms
- Fully variable release times from .1 to 3 seconds
- Feed-forward (new) or feedback (old) circuit "type"
- Hard or soft compression knee
- Automatic make-up gain
- LED gain reduction meter
- Hard-wire bypass switch (**IN**)
- API 2510 and API 2520 op-amps
- Transformer output to +28dBu

Refer to the 225L website for more information:  
<https://apiaudio.com/product/225l-compressor/>

The controls for the 225L Compressor/Limiter function as follows:



**IN** (On/off switch): Activates the module

- A hard-wired bypass is active when **ON** is not engaged
- Illuminates when engaged



**THRESH** (Threshold): Sets the activation threshold for the compressor

- +10dBu to -20dBu range

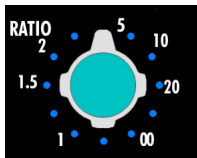

**RATIO**: Sets compression ratio applied after the threshold is exceeded

- 0 to  $\infty$  range
- 1 = 1:1... no gain reduction
- $\infty$  =  $\infty$ :1... hard limiting

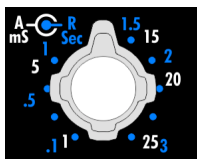

**A mS** (Attack Time): Sets the attack time

- 1 to 25 millisecond range

**R Sec** (Release Time): Sets the release time

- 1 to 3 second range



**KNEE** (HRD-SFT): Selects the curve or "knee" of the onset of compression

- HRD (Hard): Fast curve more useful for limiting applications
- SFT (Soft): Slower curve (acts as an "over-easy" compressor)



**TYPE** (New-OLD): TYPE: Selection between "new" and "old" types of compressors.

- NEW: "Feed-forward" compressor topology
- OLD: "Feed-back" compressor topology

*NOTE: The "SIDE CHAIN IN" patch point is only active when the NEW type is selected. This is due to path to the detector circuit being fed after the gain reduction element (VCA) when OLD type is selected.*

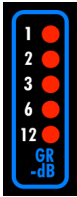

**GR -dB** (Gain-reduction Meter): 5-segment LED meter

- Indicates the amount of gain reduction
- 1, 2, 3, 6, and 12dB indications

*NOTE: The switches on this module are not part of the automation, routing, or snapshot systems.*

### 3.3.3 215L Sweep Filter

Some lower 200L slots may have 215L Sweep Filter modules installed.

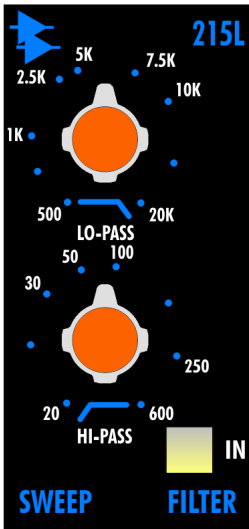

**Features:**

- Wide-range 6dB per octave LO-PASS control
- Wide-range 12dB per octave HI-PASS control
- Balanced input stage
- Passive filter design for smooth tone
- Unity gain throughout
- Hard-wire bypass switch (**IN**)
- Transformer coupled output to +28dBu
- Discrete circuit design

Refer to the 215L website for more information:  
<https://apiaudio.com/product/215l-hp-lp-sweep-filter/>

The controls for the 215L Sweep Filter function as follows:



**IN** (On/off switch): Activates the module

- A hard-wired bypass is active when **ON** is not engaged
- Illuminates when engaged

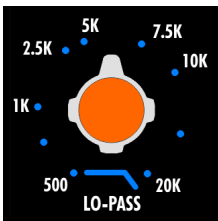

**LO-PASS**: Sets the frequency of the low-pass filter

- 500Hz to 20kHz
- 6dB per octave slope

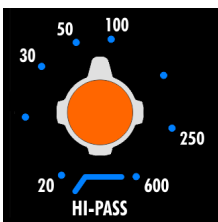

**HI-PASS**: Sets the frequency of the high-pass filter

- 20Hz to 600Hz
- 12dB per octave

*NOTE: The switches on this module are not part of the automation, routing, or snapshot systems.*

### 3.3.4 235L Gate/Expander

Some lower 200L slots may have 235L Gate/Expander modules installed.

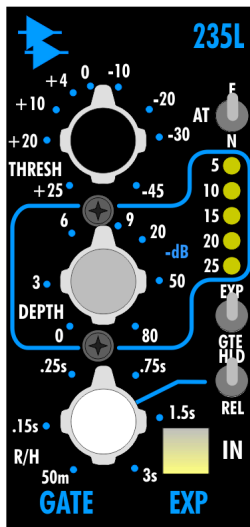

#### Features:

- Threshold control from -45 to +25dBu
- Variable adjustable depth to -80dB
- Fast and normal attack times
- Adjustable release/hold time from 50ms to 3 seconds
- 2:1 expander or gate selection
- Release or hold switch for release time control
- LED gain reduction meter
- Hard-wire bypass switch (**IN**)
- Uses the API 2510 and API 2520 op-amps
- Transformer output to +28dBu

Refer to the 235L website for more information:

<https://apiaudio.com/product/235l-noise-gate/>

The controls for the 235L Noise Gate/Expander function as follows:



**IN** (On/off switch): Activates the module

- A hard-wired bypass is active when **IN** is not engaged
- Illuminates when engaged



**EXP/GTE** (Expander/Gate): Selects the expander or gate function

- **EXP** (Expander): Selects the expander function (ratio to 1:2)
- **GTE** (Gate): Selects the gate function



**THRESH** (Threshold): Sets the activation threshold

- +25 to -45dB

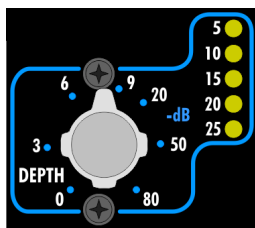

**DEPTH**: Sets the amount of attenuation (gain reduction)

- 0 to -80dB
- 5-segment LED gain-reduction meter



**AT** (Attack): Selects attack time

- **F** (Fast): Less than 100 microseconds
- **N** (Normal): 25ms (at 90% open)

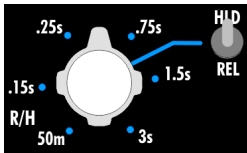

**HLD/REL (Hold/Release):** Switches between release time and hold time

- **HLD (Hold):** The R/H control determines hold time (release is set to 100ms)
- **REL (Release):** The R/H control determines Release time (hold is set to 100ms)

**R/H (Release/Hold Time):** Sets release or hold time

- The release or hold function is determined by the **HLD/REL** switch
- 50ms to 3 seconds

*NOTE: The switches on this module are not part of the automation, routing, or snapshot systems.*

## 3.4 Channel Equalization Modules

The 500L EQ slot is the third section of a channel strip and provides equalization options for the channel. There are three (3) 500L equalizer modules available for the channel strip:

- 550AL 3-band semi-parametric EQ
- 550L 4-band semi-parametric EQ
- 560L 10-band graphic EQ

Additional standard 500 Series modules may also be installed in the options bucket to provide additional equalization options: 550A Discrete 3-Band EQ, 550b 4-Band EQ, 560 Graphic EQ.

### 3.4.1 500L EQ Slot Channel Integration

Regardless of the module installed in the 500L EQ slot, it is interfaced with the channel strip as follows:

- The 500L EQ slot is routed to/from the LINE PATH and is associated with the Fader 1 audio path by default
- The 500L EQ slot will be routed to/from the MIC PATH and Fader 2 if the **EQ FDR2** switch is engaged.
- The input of 500L EQ slot of fed from the selected LINE PATH input via the EQ INPUT patch point
- The output of the 500L EQ slot feeds the FADER 1 INSERT SEND patch point via the EQ OUTPUT patch point
- The FADER 1 INSERT SEND is half-normalled to the FADER 1 INSERT RETURN patch point and feeds the Fader 1 input of the 1068L input module
- If the Fader 1 **INS** switch is engaged the signal present at the FADER 1 INSERT RETURN patch point will feed the Fader 1 input of the 1068L input module

## 3.4.2 550AL 3-Band Equalizer

The 550AL Equalizer is the console version of the famous API 550A discrete 3-band EQ.



### Features:

- 3-bands of classic API equalization
- Reciprocal and repeatable filtering
- "Proportional Q" narrows filter Q at extreme boosts and cuts
- Each band offers 7 API selected frequency centers
- Maximum 12 dB of boost/cut per band
- High and low bands can be peaking or shelving
- Mid-band is peaking only
- 50Hz to 15kHz band-pass filter
- High headroom +30dB clip level
- Hard-wired bypass with indicator

Refer to the 550a website for more information:

<https://apiaudio.com/product/550a-discrete-3-band-eq/>

The controls for the 550AL EQ function as follows:



**IN (In/out):** Activates the channel EQ

- A hard-wired bypass is active when **IN** is not engaged
- A red LED indicator illuminates when engaged



**HF (High Frequency) Frequency Selector (Center Knob):** Selects the fixed center frequency for the high band

- **2.5, 5, 7, 10, 12.5, 15, and 20 kHz**
- Frequencies are indicated in blue numbers

**HF (High Frequency) Boost/Cut (Ring):** Selects the amount of boost or cut for the selected high frequency

- **+/- 2, 4, 6, 9, and 12 dB**
- Boost and cut are indicated in white numbers

**HF (High Frequency) Peaking/Shelving Switch:** Selects between peaking and shelving EQ curves for the high frequency band

- Shelving is active when the switch is engaged

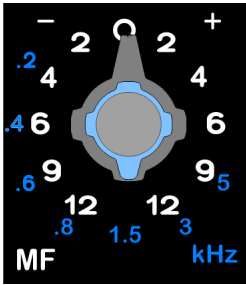

**MF (Mid Frequency) Frequency Selector (Center Knob):** Selects the fixed center frequency for the mid band

- **.2, .4, .6, .8, 1.5, 3, and 5 kHz**
- Frequencies are indicated in blue numbers

**MF (Mid Frequency) Boost/Cut (Ring):** Selects the amount of boost or cut for the selected mid frequency

- **+/- 2, 4, 6, 9, and 12 dB**
- Boost and cut are indicated in white numbers

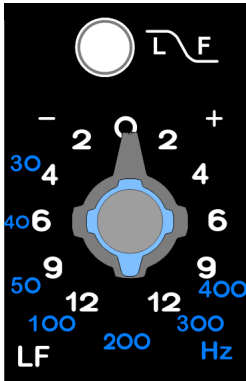

**LF (Low Frequency) Peaking/Shelving Switch:** Selects between peaking and shelving EQ curves for the low frequency band

- Shelving is active when the switch is engaged

**LF (Low Frequency) Frequency Selector (Center Knob):** Selects the fixed center frequency for the low band

- **10, 40, 50, 100, 200, 300, and 400 Hz**
- Frequencies are indicated in blue numbers

**LF (Low Frequency) Boost/Cut (Ring):** Selects the amount of boost or cut for the selected low frequency

- **+/- 2, 4, 6, 9, and 12 dB**
- Boost and cut are indicated in white numbers



**FLTR (Filter):** 50Hz to 15kHz band-pass filter

- The band-pass filter is active when engaged

*NOTE: The switches on this module are not part of the automation or routing or snapshot systems.*

**Boost and Cut (Ring):** Sets the amount of boost or cut for the selected band

- + 12dB of boost or -12dB of cut
- Decibels are indicated in white numbers

### 3.4.3 550L 4-Band Equalizer

The 550L Equalizer is the console version of the famous API 550b discrete 4-Band EQ.

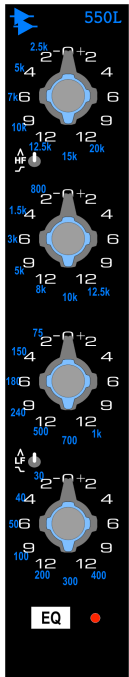

#### Features:

- 4-bands of classic API equalization
- Reciprocal and repeatable filtering
- "Proportional Q" narrows filter Q at extreme boosts and cuts
- Each band offers 7 API selected frequency centers
- Maximum 12 dB of boost/cut per band
- High and low bands can be peaking or shelving
- The high-mid and low-mid bands are peaking only
- High headroom +30dB clip level
- Hard-wired bypass with indicator
- Re-issue of 1967 API 550 EQ with an extra band

Refer to the 550b website for more information:  
<https://apiaudio.com/product/550b-4-band-eq/>

The controls for the 550: EQ function as follows:



#### **EQ (In/out):** Activates the channel EQ

- A hard-wired bypass is active when **EQ** is not engaged
- A red LED indicator illuminates when engaged

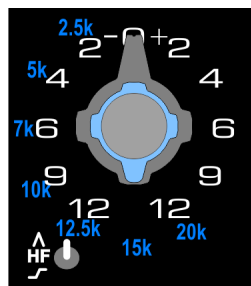

#### **HF (High Frequency) Frequency Selector (Center Knob):** Selects the fixed center frequency for the high band

- **2.5, 5, 7, 10, 12.5, 15, and 20 kHz**
- Frequencies are indicated in blue numbers

#### **HF (High Frequency) Boost/Cut (Ring):** Selects the amount of boost or cut for the selected high frequency

- **+/- 2, 4, 6, 9, and 12 dB**
- Boost and cut are indicated in white numbers

#### **HF (High Frequency) Peaking/Shelving Switch:** Selects between peaking and shelving EQ curves for the high frequency band

- Shelving is active when the switch is in the up position

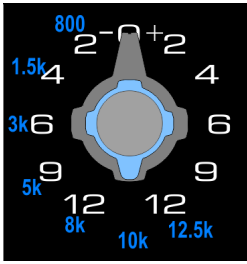

**HMF (High-Mid Frequency) Frequency Selector (Center Knob):** Selects the fixed center frequency for the high-mid band

- **.8, 1.5, 3, 5, 8, 10, and 12.5 kHz**
- Frequencies are indicated in blue numbers

**HMF (High-Mid Frequency) Boost/Cut (Ring):** Selects the amount of boost or cut for the selected high-mid frequency

- **+/- 2, 4, 6, 9, and 12 dB**
- Boost and cut are indicated in white numbers

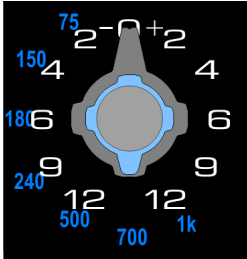

**LMF (Low-Mid Frequency) Frequency Selector (Center Knob):** Selects the fixed center frequency for the low-mid band

- **75, 150, 180, 240, 500, 700, and 1000 Hz**
- Frequencies are indicated in blue numbers

**LMF (Mid-Frequency) Boost/Cut (Ring):** Selects the amount of boost or cut for the selected low-mid frequency

- **+/- 2, 4, 6, 9, and 12 dB**
- Boost and cut are indicated in white numbers

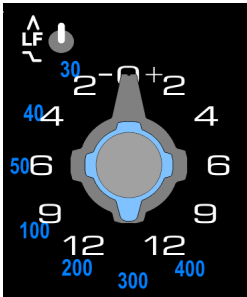

**LF (Low Frequency) Peaking/Shelving Switch:** Selects between peaking and shelving EQ curves for the low frequency band

- Shelving is active when the switch is in the up position

**LF (Low Frequency) Frequency Selector (Center Knob):** Selects the fixed center frequency for the low band

- **30, 40, 50, 100, 200, 300, and 400 Hz**
- Frequencies are indicated in blue numbers

**LF (High Frequency) Boost/Cut (Ring):** Selects the amount of boost or cut for the selected high frequency

- **+/- 2, 4, 6, 9, and 12 dB**
- Boost and cut are indicated in white numbers

*NOTE: The switches on this module are not part of the automation, routing, or snapshot systems.*

### 3.4.4 560L 10-Band Graphic Equalizer

The 560L Equalizer is the console version of the 560 discrete 10-Band Graphic EQ.

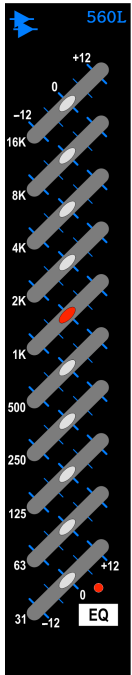

#### Features:

- 10 bands of API proprietary equalization
- Familiar graphics operation on one octave centers
- 12dB of boost/cut per band
- “Proportional Q” narrows filter Q at extreme boosts and cuts
- Additional resolution within the  $\pm 4$  region
- Center detent for reliable reset
- Silent bypass switch

Refer to the 560 website for more information:  
<https://apiaudio.com/product/560-graphic-eq/>

The controls for the 560L: EQ function as follows:



#### EQ (In/out): Activates the channel EQ

- A hard-wired bypass is active when **EQ** is not engaged
- A red LED indicator illuminates when engaged

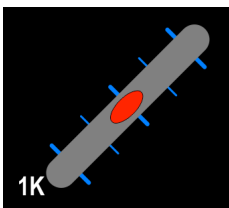

#### Boost and Cut (Slider): Sets the amount of boost or cut for the selected band

- 10-bands: 31Hz, 63Hz, 125Hz, 250Hz, 500Hz, 1kHz, 2kHz, 4kHz, 8kHz, and 16kHz
- +/- 12dB of boost or cut

*NOTE: The switch on this module is not part of the automation, routing, or snapshot systems.*

## 3.5 1068L V3 Input Module

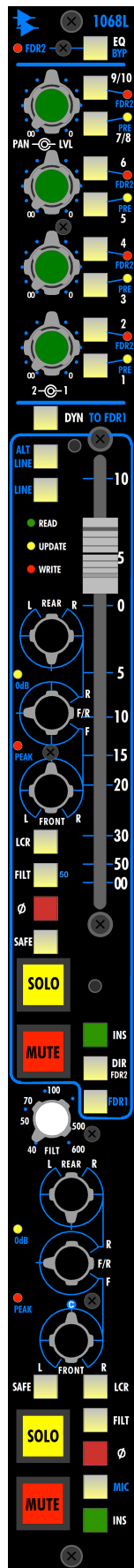

As mentioned earlier, the 1068L input module is the heart of the channel-strip. As the *Vision+* console has evolved over time, three different versions of the 1068L input module have been produced: the original 1068L (V1), the V2 version, and the most recent V3 version with enhanced features.

*NOTE: This chapter directly addresses the 1068L V3 Input Module. Original (V1) and V2 versions of the input modules will be address via notes and separate sections.*

1068L V3 is the most advanced version of the *Vision+* input module and is designed to support modern audio production as well as more traditional workflows. It also brings new features such as the alternate multitrack output to be used as an alternate line input and independent lower 200L slot routing on individual channels. As with all 1068L version, the 1068L V3 provides two fully-featured audio paths for multitrack recording (one for routing microphones to a multitrack and one for mixing the multitrack return) and/or two complete audio paths with automation and stereo/surround panning for mixing. A choice of inputs, a comprehensive set of channel patch points, and extensive output options combine with the other channel features to provide the flexibility needed to accomplish a host of audio production applications.

The 1068L V3 input module provides optimal integration with API's *Final Touch Automation*® system for easy project management, snapshots, and moving fader/switch automation. *Final Touch Automation*® includes channel routing/settings assignment function that can be used to setup, store, and recall snapshots of input/output assignments, fader positions, switch settings, auxiliary send routing, and global features for one or more channels. *Final Touch Automation*® also provides a comprehensive mixing automation system that records and plays back moves made to both channel faders, mutes, inserts, as well as the EQ bypass, and auxiliary send on/off switches.

Refer to the *Final Touch Automation*® manual for more information and operational details.

[https://www.apiaudio.com/docs/manuals/Final-Touch-Automation\\_user\\_2023-11-01.pdf](https://www.apiaudio.com/docs/manuals/Final-Touch-Automation_user_2023-11-01.pdf)

The illustration on the next page shows the 1068L V3 input module with a brief description of each control. This serves as a quick reference guide. A more detailed description of each control will follow.

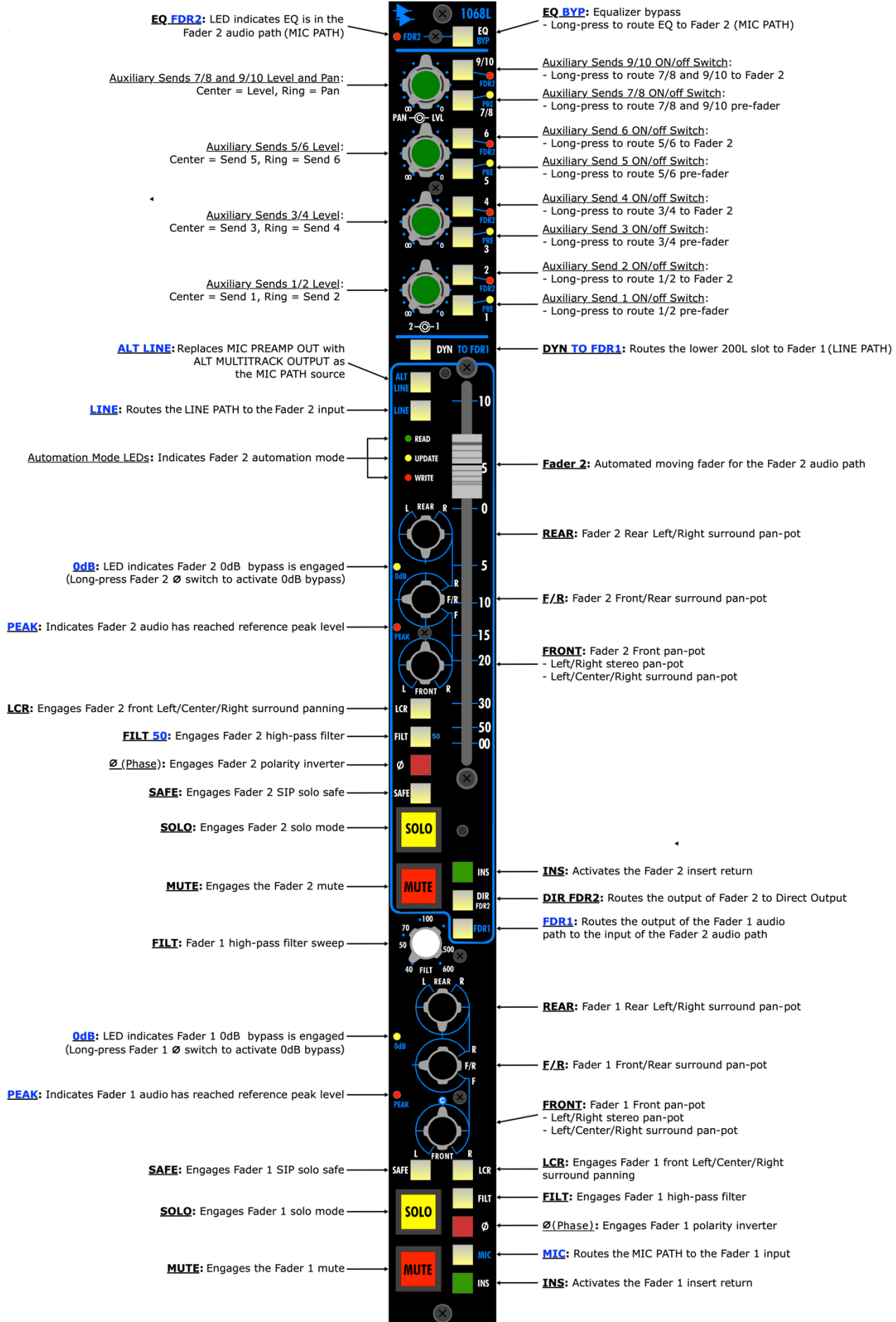

## 3.5.1 1068L V3 Input Module Controls

In this section, the controls on the 1068L V3 input module will be discussed in detail.

### 3.5.1.1 Equalizer Routing

The EQ module installed in the 500L EQ slot is assigned to the LINE PATH (Fader 1) by default.

The EQ module installed in the 500L EQ slot can be reassigned to the MIC PATH (Fader 2) using the **EQ FDR2** switch and/or bypassed completely using the **EQ BYP** switch.

In order for the EQ to be heard, the following conditions must be met:

- The EQ be assigned to the desired audio path
- The **EQ** or **IN** switch on the 500L equalizer itself must be engaged (ON)
- The **EQ BYP** switch must not be engaged

The **EQ BYP** (bypass) switch is a dual-function switch that functions as follows:

- **EQ BYP**: Removes the 500L EQ slot from the assigned audio path
  - Hard-wire bypass
  - Press and release to activate
  - Automation control
  - Switch illuminates when engaged
- **EQ FDR2**: Moves the EQ (and its patch points) from the LINE PATH (Fader 1) to the MIC PATH (Fader 2)
  - Long-press (press and hold) to activate
  - Routing/Snapshot control
  - Red LED illuminates when engaged

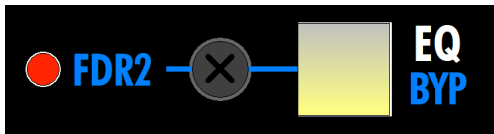

Assigning the EQ to MIC PATH (Fader 2) can be set on individual channels on the 1068L module or on multiple channels using the *Final Touch Automation*® routing system. EQ routing can also be stored and recalled using snapshots.

Refer to sections 18.0 Snapshots and 21.2 Vision Routing and Snapshots in the *Final Touch Automation*® manual for more information about routing, snapshots, and operational details. [https://www.apiaudio.com/docs/manuals/Final-Touch-Automation\\_user\\_2023-11-01.pdf](https://www.apiaudio.com/docs/manuals/Final-Touch-Automation_user_2023-11-01.pdf)

### 3.5.1.2 Auxiliary Sends

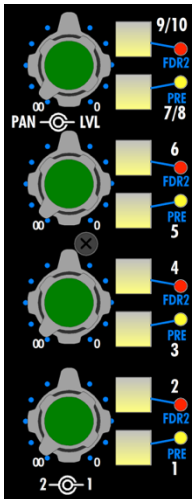

The *Vision+* console provides a powerful auxiliary send system that provides a comprehensive set of options for cue sends (headphone feeds), effects sends, and other auxiliary mix applications.

The 1068L V3 is equipped with a total of ten (10) auxiliary sends:

- Six (6) mono sends (1-6)
- Two (2) stereo sends (7/8 and 9/10)

Auxiliary sends 1-6 are primarily used as effects sends during recording and mixing, but may be also be used as cue sends during recording if needed.

Auxiliary sends 7/8 and 9/10 are intended for use as cue sends during recording and as stereo effects sends during mixing.

All auxiliary sends are routed post-fader from the Fader 1 audio path by default. All sends can be routed pre-fader and/or from Fader 2 in pairs (1-2, 3-4, etc.). Routing for sends 7/8 and 9/10 is always the same.

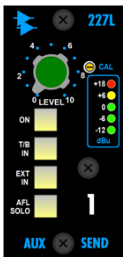

Each of the auxiliary sends feed their respective auxiliary summing bus. The output of each of these buses is fed to the corresponding 227L module in the center section. An external input source and talkback may be added before the module's output. **ON**/off, output level, AFL solo controls, and a level meter are also included on the 227L module.

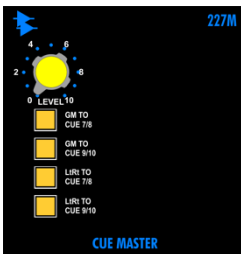

For increased flexibility, especially when used for cue sends, the following stereo audio sources may be added to the 7/8 and 9/10 auxiliary buses at the 227M cue master module:

- Grand Master output
- Lt Rt Fold Down Matrix output

Refer to section 9.0 Auxiliary Send Masters in this manual for further information.

Auxiliary sends 9/10 may be routed to multitrack summing buses 1-8 to provide additional summing outputs. This can be done on individual channels using the output assignment module or using global controls in the *Final Touch Automation*® routing system.

*NOTE: When auxiliary sends 9/10 are routed to the multitrack summing buses, the feed to auxiliary bus 9/10 from that channel is defeated.*

Refer to section 4.0 Output Assignment in this manual and/or sections 18.0 Snapshots and 21.2 Vision Routing and Snapshots in the *Final Touch Automation*® manual for more information about routing, snapshots, and operational details.

[https://www.apiaudio.com/docs/manuals/Final-Touch-Automation\\_user\\_2023-11-01.pdf](https://www.apiaudio.com/docs/manuals/Final-Touch-Automation_user_2023-11-01.pdf)

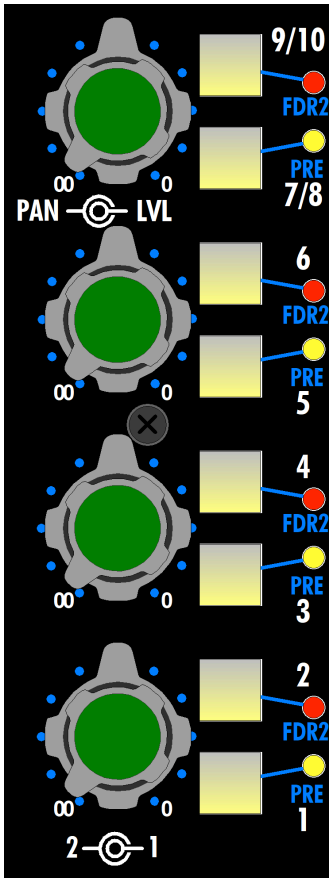

Auxiliary sends are organized in pairs and assigned in four groups:

- Mono 1 and 2
- Mono 3 and 4
- Mono 5 and 6
- Stereo 7/8 and 9/10

Each group of auxiliary sends may be sourced as follows:

- Fader 1 or Fader 2 audio path
- Pre or post the assigned fader

Routing assignments may be made:

- Locally on the 1068L input module
- Routing/Snapshot control

The status of each group of auxiliary sends is indicated as follows:

- **ON**/off switch illuminates when the send is ON
- Red **FDR2** LED illuminates when the pair is fed from Fader 2
- Yellow **PRE** LED illuminates when the pair is fed pre-fader

*IMPORTANT NOTE: Stereo auxiliary sends 7/8 and 9/10 may be used at the same time, but will have the same routing, level, and panning.*

Each auxiliary send in each group, mono or stereo, is equipped with a dual-function switch, labeled with its send number (1-6, 7/8, or 9/10). This send switch functions as follows:

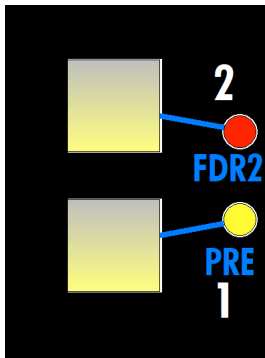

- **Send ON/off**: Activates the send
  - Press and release to activate
  - Automation control
  - Switch illuminates when engaged
- **FDR2**: Routes the pair of sends from the Fader 2 audio path
  - Long-press (press and hold) the **ON**/off switch for the higher, even-numbered send to activate
  - Routing/Snapshot control
  - Red LED illuminates when engaged
- **PRE**: Routes the pair of sends pre-fader from the assigned path
  - Long-press (press and hold) the **ON**/off switch for the lower send to activate
  - Routing/Snapshot control
  - Yellow LED illuminates when engaged



A dual-concentric pot is provided to control the levels for each pair mono auxiliary sends: 1-2, 3-4, 5-6. The inner knob controls the level of the lower odd-numbered send and the ring controls the level of the higher even-numbered send.

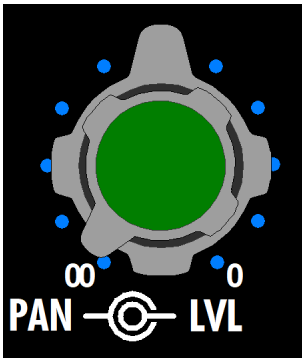

A single dual-concentric pot is provided to control the level and panning for the pair of stereo auxiliary sends: 7/8 and 9/10. The inner knob controls the level and the ring controls the panning for both stereo sends.

### Aux Pre Mute Function

The pre-fader auxiliary sends can be made to mute when the channel **MUTE** switch is engaged. This is accomplished by engaging the **AUX PRE MUTE** switch in the SOLO area of the center section.



**AUX PRE MUTE:** Links the 1068L **MUTE** switches with the **ON/off** switch on pre-fader auxiliary sends

- All pre-fader auxiliary sends turn off when a channel **MUTE** switch is engaged
- Illuminates in yellow when engaged

### 3.5.1.3 Lower 200L Slot (Dynamics) Routing

A 225L Compressor/Limiter is often installed in the lower 200L slot in order to provide dynamic processing to the channel. To this end, this 200L slot/module is referred to as "dynamics" or "DYN" on the 1068L V3 input module and in the *Vision+* channel patch bay.

The module installed in the lower 200L slot is assigned to the MIC PATH (Fader 2) by default.

In order for the DYN (lower 200L) module to be heard, the following conditions must be met:

- DYN (lower 200L slot) be assigned to the desired path
- The **IN** switch on the lower 200L module itself must be engaged (ON)

It can be assigned to the LINE PATH (Fader 1) using the **DYN TO FDR1** switch.



**DYN TO FDR1**: Routes the lower 200L slot to the LINE PATH (Fader 1)

- Routing/Snapshot control
- Switch illuminates when engaged

Assigning the lower 200L slot (**DYN**) to the LINE PATH (Fader 1) can be set on individual channels on the 1068L module or on multiple channels using the *Final Touch Automation*<sup>®</sup> routing system. DYN routing can also be stored and recalled using snapshots.

Refer to sections 18.0 Snapshots and 21.2 Vision Routing and Snapshots in the *Final Touch Automation*<sup>®</sup> manual for more information about routing, snapshots, and operational details. [https://www.apiaudio.com/docs/manuals/Final-Touch-Automation\\_user\\_2023-11-01.pdf](https://www.apiaudio.com/docs/manuals/Final-Touch-Automation_user_2023-11-01.pdf)

### 3.5.1.4 Fader 2 Controls

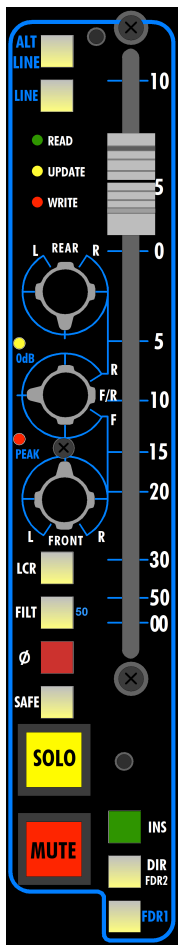

The 1068L V3 Fader 2 audio path (also referred to as “mic path”) is a complete audio channel designed to serve the following functions:

- Routing microphone and instrument inputs to a multitrack recorder
- Multitrack returns for additional inputs during mixdown
- Retuning effects, virtual tracks, and other sources during mixdown
- LFE send during mixdown
- Additional aux send during mixdown
- Creating stems and bouncing tracks
- Any other operation that needs a fully-featured audio path

Accordingly, the Fader 2 audio path is equipped with the following features (in the order they appear in the signal flow):

- MIC PATH (default), LINE PATH, or ALT LINE (ALT MULTITRACK OUTPUT) input source selection
- Fader 1 output is available as an alternate Fader 2 input option
- Assignable lower 200L slot processing (DYN)
- Assignable EQ
- Insert send with automatable return
- Phase reverse (polarity inverter)
- Peak indicator
- Full-sized automatable moving fader
- 0dB fader bypass function
- 50Hz high-pass filter
- Automatable mute
- Full solo functions with solo safe
- Assignable to the direct output
- Program and multitrack bus output routing
- Stereo/surround panning
- Auxiliary send routing
- Access to channel meter (depending on master meter selection)

In the section that follows, the controls for the MIC PATH and Fader 2 audio paths are described in detail in the order they appear in the signal flow.

The 1068L V3 Fader 2 audio path supports three inputs, all of which are accessible in the channel patch bay.

- **MIC**: The output of the MIC PATH (preamp output, lower 200L slot, and Fader 2 insert)
  - MIC PREAMP OUT half-normalled to MIC PATH INPUT patch points
- **LINE**: The output of the LINE PATH (multitrack output, 500L EQ, and Fader 1 insert)
  - MULTITRACK OUT half-normalled to LINE PATH INPUT patch points
- **ALT LINE**: Signals from the ALT MULTITRACK OUTPUT patch points

The MIC PATH is the default input for Fader 2. The LINE PATH can be selected for the Fader 2 source using the **LINE** switch. The ALT MULTITRACK OUTPUT can be selected for the Fader 2 source using the **ALT LINE** switch.

Inputs can be changed on individual channels using the following switches on the 1068L V3 input module:



**LINE**: Routes the LINE PATH (multitrack output) to the Fader 2 input

- Replaces MIC PATH or ALT LINE source as the Fader 2 input
- Routing/Snapshot control
- Illuminates when engaged

*NOTE: The input for Fader 2 may be set to the LINE PATH on all channels by engaging the **FDR2 LINE** master input selector switch (INPUT SELECT) in the center section.*

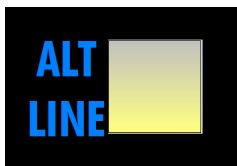

**ALT LINE**: Replaces the MIC PREAMP OUTPUT with the ALT MULTITRACK OUTPUT as the MIC PATH input source and routes patch point to the either audio path as follows:

- Fader 2: Replaces MIC PREAMP as the Fader 2 input source when engaged
- Fader 1: Replaces LINE PATH as the Fader 1 input source when engaged, along with the **MIC** switch
- Illuminates when engaged

*NOTE: There are no patch bay normals that feed the ALT MULTITRACK OUTPUT patch points. However, the signal is received from the 3-pin EDAC connectors associated with each point. Alternately, patching from a line-level source into these point will replace the alternate multitrack source.*



**FDR1**: Routes the output of the Fader 1 audio path to the Fader 2 input

- Replaces the MIC, LINE, or ALT LINE source as the Fader 2 input
- Routing/Snapshot control
- Illuminates when engaged



**DYN TO FDR1**: Routes the lower 200L slot to the LINE PATH (Fader 1)

- Lower 200L slot is routed to the MIC PATH by default
- Routing/Snapshot control
- Switch illuminates when engaged

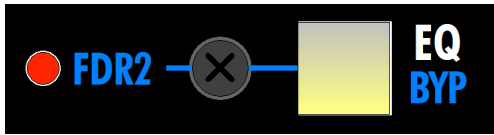

**EQ BYP** (bypass) is a dual-function switch that functions as follows:

- **EQ BYP**: Removes the 500L EQ slot from the assigned audio path
  - Hard-wire bypass
  - Press and release to activate
  - Automation control
  - Switch illuminates when engaged
- **EQ FDR2**: Moves the EQ (and its patch points) from the LINE PATH (Fader 1) to the MIC PATH (Fader 2)
  - Long-press (press and hold) to activate
  - Routing/Snapshot control
  - Red LED illuminates when engaged



**INS** (Insert): Activates the Fader 2 insert return

- Insert send is fed pre-fader from the output of the lower 200L slot in the PREAMP INPUT path
- Insert send feeds the FADER 2 INSERT SEND patch point and is always active
- Insert return is located before the 1068L Fader 2 input in the PREAMP INPUT path
- Insert return is fed from the FADER 2 INSERT RETURN patch point
- Insert return is active only when the **INS** switch is engaged
- Automation control
- Illuminates in green when engaged



**Ø** (Phase Reverse): Inserts a polarity inverter in the Fader 2 audio path

- Located at 1068L Fader 2 input
- Routing/Snapshot control
- Illuminates in red when engaged

Long-pressing (press and hold) the **Ø** switch will active the 0dB fader bypass in the Fader 2 audio path.



**FDR1** (Fader 1 Output): Routes the output of Fader 1 audio path to the Fader 2 audio path input

- Fader 1 output is routed to the Fader 2 audio path input, post the polarity inverter (phase reverse) and before the fader
- Useful for creating a LFE feed or an additional auxiliary send using the Fader 2 audio path
- Useful for creating stems and bouncing tracks
- Routing/Snapshot control
- Illuminates when engaged



**PEAK**: A red LED illuminates when the preset peak reference level is reached in the Fader 2 audio path

- Peak level is selected by the **PEAK REFERENCE** control in the center section

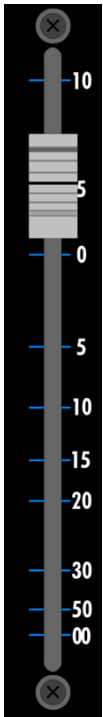

**FADER 2:** Controls the output level of the Fader 2 audio path

- 0dB is unity gain
- Touch sensitive, full-sized 100mm, motorized moving fader
- Automation control



**0dB:** Illuminates in yellow when the Fader 2 0dB bypass is engaged

- Long-press (press and hold) the  $\emptyset$  switch to activate

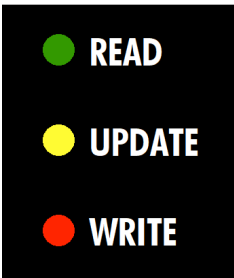

**READ, UPDATE, WRITE:** Automation mode indicators

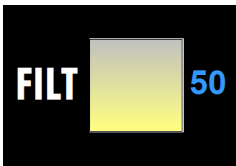

**FILT (Filter):** Activates the Fader 2 high-pass filter

- -3 dB at 50Hz (fixed)
- 12dB/octave slope
- Located post-fader, pre-mute
- Routing/Snapshot control
- Illuminates when engaged



**MUTE:** Cuts the Fader 2 audio output

- **MUTE** switch is the on/off switch for the Fader 2 audio path
- Automated with *Final Touch Automation*<sup>®</sup>
- Illuminates in red when engaged



**DIR FDR2 (Direct Output Fader 2):** Routes the output of Fader 2 audio path to the direct output

- Direct output is fed POST the MUTE switch
- Direct output is fed from Fader 1 by default
- Feeds the DIRECT OUTPUT patch point, which is half-normalled to the MULTITRACK INPUT patch point
- Illuminates when engaged

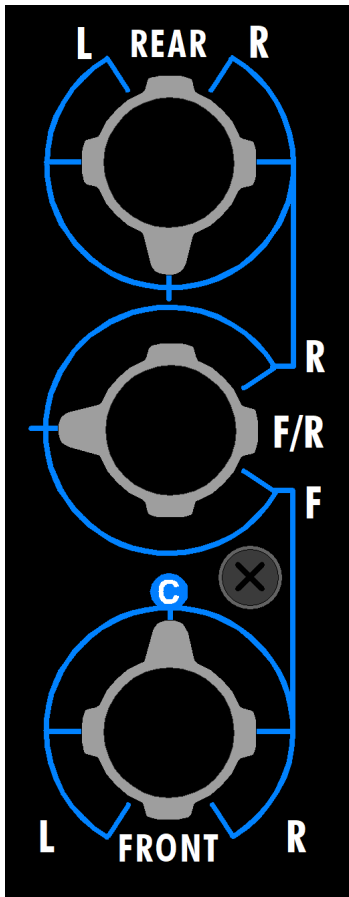

## Fader 2 Pan-Pots

### **REAR (Left-Right):** Rear left-right pan-pot

- Sets the rear left-right pan position to the surround program buses
- Center detent

### **F/R (Front/Rear):** Front-Rear pan-pot

- Sets the front/rear pan position to the surround program buses
- Center detent

### **FRONT (Left-Right):** Stereo left-right and front surround left-right pan-pot

- Dual independent pan-pots on one shaft
- One sets the left-right panning to the stereo program buses
- One sets the front panning to the FRONT surround program buses
- Left-right panning is selected by default for surround panning
- Front left-center-right panning can be enabled for surround mixing by engaging the **LCR** switch
- Center detent

*IMPORTANT NOTE: The **FRONT** pan-pot is two pan-pots ganged together to a single knob. When assigned, one pan-pot feeds the left-right stereo program buses A, B, and C, and the other feeds the front left-right or left-center-right surround program buses. Because of this innovative design, the **F/R** pan-pot has no affect on the feed to the stereo program buses, allowing simultaneous stereo and surround mixing without using the Lt Rt fold down matrix.*

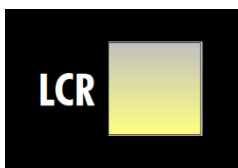

### **LCR (Left Center Right):** Activates left-center-right panning for Fader 2

- Activates feed to center program bus from the **FRONT** pan-pot
- Audio panned front and center **C** is fed to the center surround program bus when engaged
- Audio panned front and center **C** is not fed to the surround left and surround right program buses
- Stereo left-right front surround panning is selected by default
- Routing/Snapshot control
- Illuminates when engaged



**SOLO:** Activates the selected solo function for Fader 2

- The following solo functions may be selected in the center section:
  - Pre-fader Listen (PFL): Non-destructive, mono, solo bus
  - After Fader Listen (AFL): Non-destructive, stereo, solo bus
  - Solo-In-Place (SIP): Destructive, panned, post-fader, program bus
- Illuminates in yellow when engaged

*NOTE: AFL is the default solo mode.*



**SAFE:** Activates the solo safe mode for Fader 2

- Inhibits Fader 2 muting when Solo-In-Place is active and another channel is soloed
- Routing/Snapshot control
- Illuminates when engaged

### 3.5.1.5 Fader 1 Controls

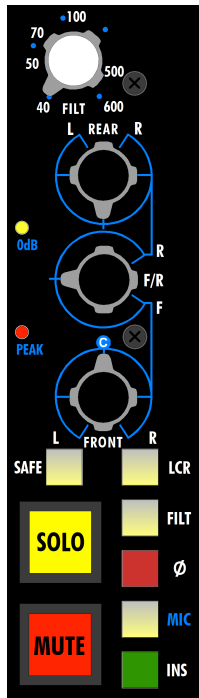

Coupled with a 1044L fader pack, the 1068L V3 Fader 1 audio path is a complete audio channel designed to serve the following functions:

- Multitrack returns during tracking and mixdown
- Retuning effects, virtual tracks, and other sources during mixdown
- Routing microphone and instrument inputs to a live stereo and/or surround mix
- Routing microphone and instrument inputs to a multitrack recorder
- Creating stems and bouncing tracks
- Any other operation that needs a fully-featured audio path

Accordingly, the Fader 1 audio path is equipped with the following features (in the order they appear in the signal flow):

- LINE PATH (default), MIC PATH, or ALT LINE (ALT MULTITRACK OUTPUT) input source selection
- Assignable EQ
- Insert send with automatable return
- Phase reverse (polarity inverter)
- Touch sensitive, full-sized 100mm, motorized moving fader (1044L)
- 0dB fader bypass function
- Peak Indicator
- High-pass sweep filter
- Automatable mute
- Direct output
- Stereo/surround panning
- Program and multitrack bus output routing
- Auxiliary send routing
- Full solo functions with solo safe
- Access to channel meter (depending center section METER SELECTION)

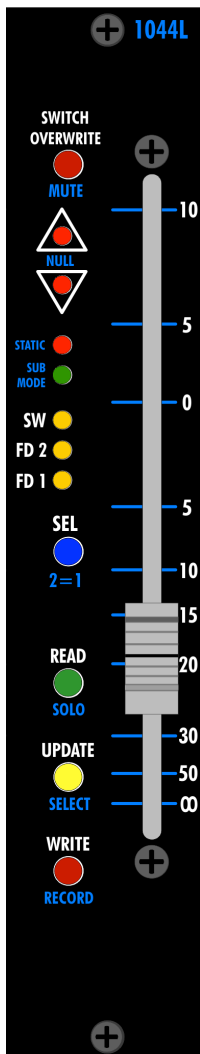

In the section that follows, the controls for the LINE PATH and Fader 1 audio path are described in detail in the order they appear in the signal flow.

The 1068L V3 Fader 1 audio path supports three inputs, all of which are accessible in the channel patch bay.

- **MIC**: The output of the MIC PATH (preamp, lower 200L slot, and Fader 2 insert)
  - MIC PREAMP OUT half-normalled to MIC PATH INPUT patch points
- **LINE**: The output of the LINE PATH (line in, 500L EQ, and Fader 1 insert)
  - MULTITRACK OUT half-normalled to LINE PATH INPUT patch points
- **ALT LINE**: Signals from the ALT MULTITRACK OUTPUT patch points

The LINE PATH is the default input for Fader 1. The MIC PATH can be selected as the Fader 1 source using the **MIC** switch. The ALT MULTITRACK OUTPUT can be selected as the Fader 1 source using both the **MIC** and **ALT LINE** switches.

Inputs can be changed on individual channels using the following switches on the 1068L V3 input module:

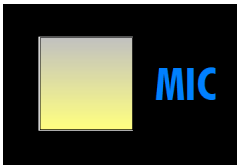

**MIC**: Routes the MIC PATH (preamp out) to the Fader 1 input

- Replaces the LINE PATH as the Fader 1 input
- Routing/Snapshot control
- Illuminates when engaged

*NOTE: The input for Fader 1 may be set to the MIC PATH on all channels by engaging the **FDR1 MIC** master input selector switch (INPUT SELECT) in the center section.*

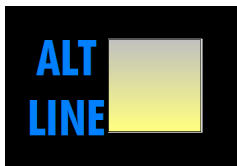

**ALT LINE**: Replaces the MIC PREAMP OUTPUT with the ALT MULTITRACK OUTPUT as the MIC PATH input source and routes patch point to the either audio path as follows:

- Fader 2: Replaces MIC PREAMP as the Fader 2 input source when engaged
- Fader 1: Replaces LINE PATH as the Fader 1 input source when engaged, along with the **MIC** switch
- Illuminates when engaged

*NOTE: There are no patch bay normals that feed the ALT MULTITRACK OUTPUT patch points. However, the signal is received from the 3-pin EDAC connectors associated with each point. Alternately, patching from a line-level source into these point will replace the alternate multitrack source.*



**DYN TO FDR1**: Routes the lower 200L slot to the LINE PATH (Fader 1)

- Lower 200L slot is routed to the MIC PATH by default
- Routing/Snapshot control
- Switch illuminates when engaged

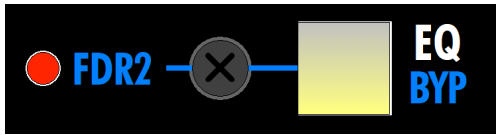

**EQ BYP** (bypass) is a dual-function switch that functions as follows:

- **EQ BYP**: Removes the 500L EQ slot from the assigned audio path
  - Hard-wire bypass
  - Press and release to activate
  - Automation control
  - Switch illuminates when engaged
- **EQ FDR2**: Moves the EQ (and its patch points) from the LINE PATH (Fader 1) to the MIC PATH (Fader 2)
  - Long-press (press and hold) to activate
  - Routing/Snapshot control
  - Red LED illuminates when engaged



**INS** (Insert): Activates the Fader 1 insert return

- Insert send is fed pre-fader from the output of the 500L EQ slot in the LINE INPUT path
- Insert send feeds the FADER 1 INSERT SEND patch point and is always active
- Insert return is located before the 1068L Fader 1 input in the LINE INPUT path
- Insert return is fed from the FADER 1 INSERT RETURN patch point
- Insert return is active only when the **INS** switch is engaged
- Automation control
- Illuminates in green when engaged



**Ø** (Phase Reverse): Inserts a polarity inverter in the Fader 1 audio path

- Located at 1068L Fader 1 input
- Routing/Snapshot control
- Illuminates in red when engaged

Long-pressing (press and hold) the **Ø** switch will activate the 0dB fader bypass in the Fader 1 audio path.



**PEAK**: A red LED illuminates when the preset peak reference level is reached in the Fader 1 audio path

- Peak level is selected by the **PEAK REFERENCE** control in the center section

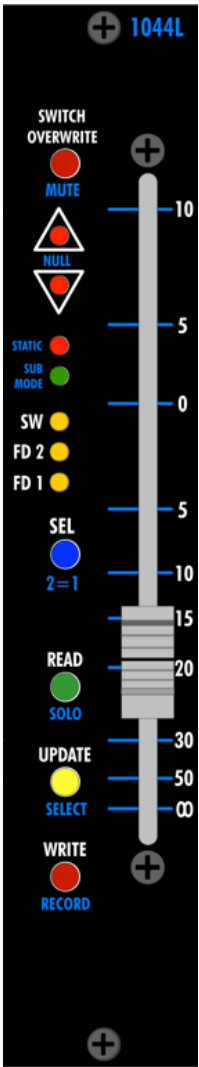

**FADER 1:** Controls the output level of the Fader 1 audio path

- 0dB is unity gain
- Touch sensitive, full-sized 100mm, motorized fader
- Automation control
- 0dB fader bypass (long-press the Ø switch to activate)



**0dB:** Illuminates in yellow when the Fader 1 0dB bypass is engaged

- Long-press (press and hold) the Ø switch to activate



Automation Switches and Indicators



**FILT (Filter) Switch:** Activates the Fader 1 high-pass sweep filter

- 12dB/octave slope
- Located post-fader, pre-mute
- Routing/Snapshot control
- Illuminates when engaged

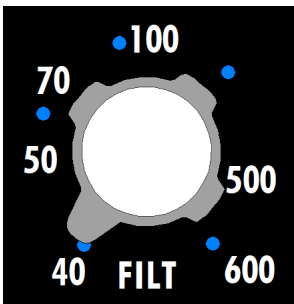

**FILT (Filter) Sweep:** Sets the Fader 1 high-pass filter frequency

- 40Hz to 600Hz sweep
- 12dB/octave slope
- Located Post-Fader
- Active when **FILT** switch is engaged



**MUTE:** Cuts the Fader 1 audio output

- **MUTE** switch is the on/off switch for the Fader 1 audio path
- Automation control
- Illuminates in red when engaged

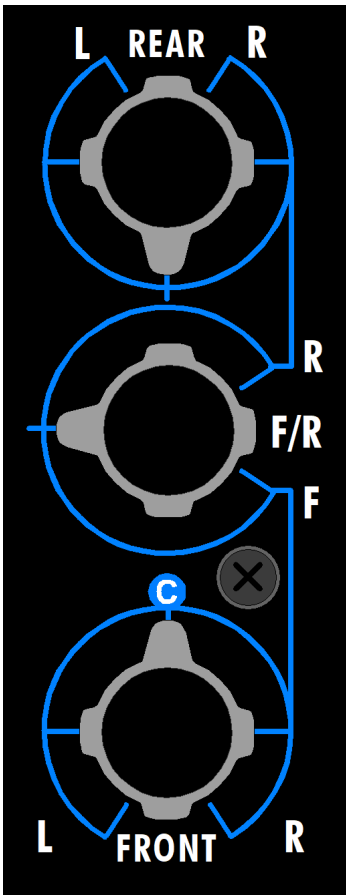

### Fader 1 Pan-Pots

**REAR (Left-Right):** Rear left-right pan-pot

- Sets the rear left-right pan position to the surround program buses
- Center detent

**F/R (Front/Rear):** Front-Rear pan-pot

- Sets the front/rear pan position to the surround program buses
- Center detent

**FRONT (Left-Right):** Stereo left-right and front surround left-right pan-pot

- Dual independent pan-pots on one shaft
- One sets the left-right panning to the stereo program buses
- One sets the front panning to the FRONT surround program buses
- Left-right panning is selected by default for surround panning
- Front left-center-right panning can be enabled for surround mixing by engaging the **LCR** switch
- Center detent

*IMPORTANT NOTE: The **FRONT** pan-pot is two pan-pots ganged together to a single knob. When assigned, one pan-pot feeds the left-right stereo program buses A, B, and C, and the other feeds the front left-right or left-center-right surround program buses. Because of this innovative design, the **F/R** pan-pot has no affect on the feed to the stereo program buses, allowing simultaneous stereo and surround mixing without using the Lt Rt fold down matrix.*

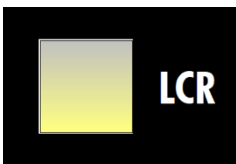

**LCR (Left Center Right):** Activates left-center-right panning for Fader 1

- Activates feed to center program bus from the **FRONT** pan-pot
- Audio panned front and center **C** is fed to the center surround program bus when engaged
- Audio panned front and center **C** is not fed to the surround left and surround right program buses
- Stereo left-right front surround panning is selected by default
- Routing/Snapshot control
- Illuminates when engaged



**SAFE:** Activates the solo safe mode for Fader 1

- Inhibits Fader 1 muting when Solo-In-Place is active and another channel is soloed
- Routing/Snapshot control
- Illuminates when engaged



**SOLO:** Activates the selected solo function for Fader 1

- The following solo functions may be selected in the center section:
  - Pre-fader Listen (PFL): Non-destructive, mono, solo bus
  - After Fader Listen (AFL): Non-destructive, stereo, solo bus
  - Solo-In-Place (SIP): Destructive, panned, post-fader, program bus
- Illuminates in yellow when engaged

*NOTE: AFL is the default solo mode.*

### 3.5.1.6 1068L Routing/Snapshot Control

In addition to being controlled directly from the console controls, the positions of several switches on the 1068L V3 input module may be set, stored, and recalled using the routing and snapshot systems in the *Final Touch Automation*® system.

#### 1068L V3 Routing/Snapshot Controls:

The positions of the following switches may be set, stored, and recalled using the routing or snapshot systems:

##### Channel:

- **EQ TO FDR2** (EQ to Fader 2)
- **DYN TO FDR1** (Dynamics to Fader 1)
- **ALT LINE** (alternate multitrack output)
- **Pan to 24** (Odd/even panning to multitrack summing buses)
- **9/10 to 1-8** (Aux 9/10 to multitrack summing buses 1-8)
- **F2 to 24** (Fader 2 to multitrack summing buses)
- **DIR FDR2** (Fader 2 to direct output)

##### Fader 1:

- Fader position (snapshot only)
- 0dB bypass (long-press Ø)
- Solo **SAFE**
- Ø (polarity inverter)
- **FILT** (high-pass filter)
- **STA, STB, STC, 5.1** (program bus assignment)
- **PAN** (stereo pan-pot engage)
- **LCR** (Left, Center, Right front surround panning)
- **MIC** (MIC PATH input)
- **2=1** (Fader 2 follows Fader 1 position)

### Fader 2:

- Fader position (snapshot only)
- 0dB bypass (long-press **Ø**)
- Solo **SAFE**
- **Ø** (polarity inverter)
- **FILT** (high-pass filter)
- **STA, STB, STC, 5.1** (program bus assignment)
- **PAN** (stereo pan-pot engage)
- **LCR** (Left, Center, Right front surround panning)
- **LINE** (LINE PATH input)
- **FDR1** (Fader 2 input feed from Fader 1 output)

### Auxiliary Send Routing:

The following auxiliary send and global routing options may be set, stored, and recalled using the routing or snapshot systems:

- Auxiliary Send 1 **ON/off**
- Auxiliary Send 2 **ON/off**
- Send 1/2 -> PRE
- Send 1/2 -> FDR 2
- Auxiliary Send 3 **ON/off**
- Auxiliary Send 4 **ON/off**
- Send 3/4 -> PRE
- Send 3/4 -> FDR 2
- Auxiliary Send 5 **ON/off**
- Auxiliary Send 6 **ON/off**
- Send 5/6 -> PRE
- Send 5/6 -> FDR 2
- Auxiliary Send 7/8 **ON/off**
- Auxiliary Send 9/10 **ON/off**
- Send 7/8 and 9/10 -> PRE
- Send 7/8 and 9/10 -> FDR 2
- 9/10 to Bus 1-8

*NOTE: Auxiliary sends 9/10 follow the same routing as auxiliary sends 7/8.*

### Multitrack Bus Assignments:

- 1-24

Refer to sections 18.0 Snapshots and 21.2 Vision Routing and Snapshots in the *Final Touch Automation*® manual for more information about routing, snapshots, and operational details. [https://www.apiaudio.com/docs/manuals/Final-Touch-Automation\\_user\\_2023-11-01.pdf](https://www.apiaudio.com/docs/manuals/Final-Touch-Automation_user_2023-11-01.pdf)

### 3.5.1.7 1068L Automation Controls

In addition to being controlled from the console control surface, the positions of several 1068L V3 input module controls may be automated using the *Final Touch Automation*<sup>®</sup> system.

The positions of the following 1068L may be automated using the automation system:

- **EQ BYP** (EQ bypass)
- Fader 1 **INS** (insert)
- Fader 2 **INS** (insert)
- Fader 1 (1044L module)
- Fader 1 **MUTE**
- Fader 2
- Fader 2 **MUTE**
- Auxiliary Send 1 **ON/off**
- Auxiliary Send 2 **ON/off**
- Auxiliary Send 3 **ON/off**
- Auxiliary Send 4 **ON/off**
- Auxiliary Send 5 **ON/off**
- Auxiliary Send 6 **ON/off**
- Auxiliary Send 7/8 **ON/off**
- Auxiliary Send 9/10 **ON/off**

Refer to sections 18.0 Snapshots and 21.2 Vision Routing and Snapshots in the *Final Touch Automation*<sup>®</sup> manual for more information about routing, snapshots, and operational details.

[https://www.apiaudio.com/docs/manuals/Final-Touch-Automation\\_user\\_2023-11-01.pdf](https://www.apiaudio.com/docs/manuals/Final-Touch-Automation_user_2023-11-01.pdf)

## 3.6 Channel Faders

Each audio path has its own output fader:

- Fader 1 (LINE path)
- Fader 2 (MIC path)

Each fader is a touch-sensitive, full-sized (100mm), moving fader with automation control.

Fader 1 and/or Fader 2 faders can be set to a common position on a global basis via the *Final Touch Automation*<sup>®</sup> position faders function.

Each fader is located before the high-pass filter and mute switch at the end of each audio path.

Details pertaining to each individual fader are included in the following sections.

### 3.6.1 Fader 1

The fader for the Fader 1 audio path is located in the four-channel 1044L fader module located at the bottom of each group of four channel strips. The Fader 1 faders in the 1044L module are the primary level controls for the Fader 1 audio paths for the corresponding group of channels.

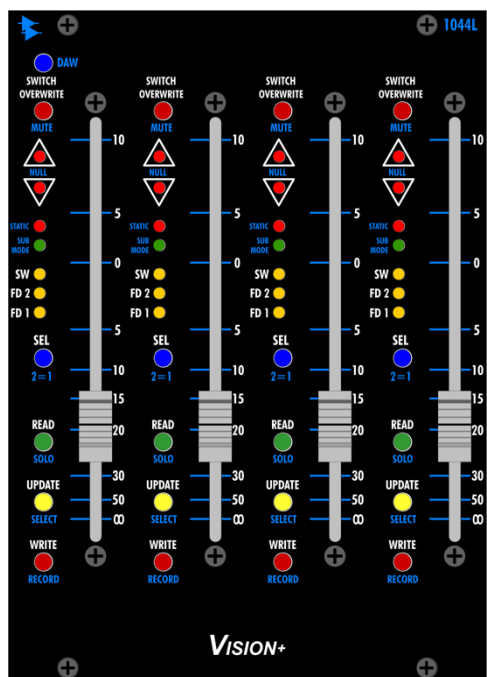

**FADER 1:** Controls the output level of the Fader 1 audio path

- 0dB is unity gain
- Automation control
  - Full-sized 100mm motorized moving fader
  - Touch sensitive automation control
  - Controls for fader and switch automation (both paths)
- DAW control
- 0dB fader bypass

The diagram on the next page illustrates the 1044L fader controls in more detail.

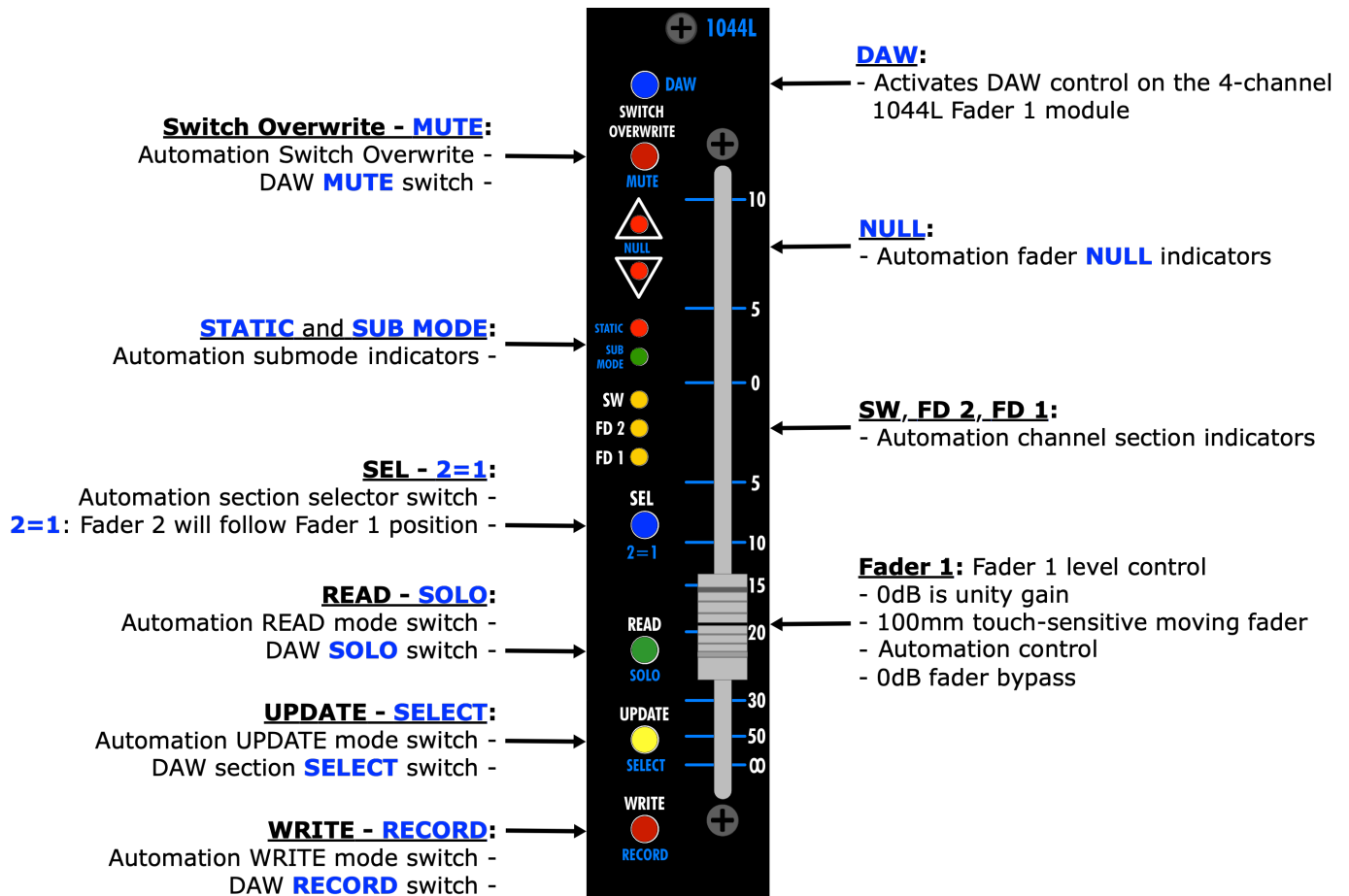

### 3.6.2 Fader 2

The Fader 2 fader is an integral part of the 1068L input module and is the primary level control for the Fader 2 audio path.

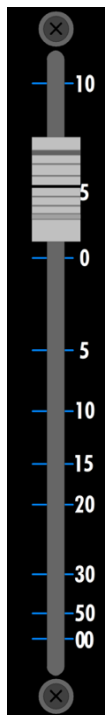

**FADER 2:** Controls the output level of the Fader 2 audio path

- 0dB is unity gain
- Full-sized 100mm motorized moving fader
- Automation control
- Touch sensitive automation control
- 0dB fader bypass



**0dB:** Illuminates in yellow when the Fader 2 0dB bypass is engaged

- Long-press (press and hold) the  $\emptyset$  switch to activate



**READ, UPDATE, WRITE:** Automation mode indicators

### 3.6.3 Position Faders

Fader 1 and/or Fader 2 faders can be set to a common position on an individual, subset, or global basis using API's *Final Touch Automation*®. The selected faders will all be set to same position.

Use the "Position Faders" function to set a specified set of faders to a specific level.

To initiate the "Position Faders" function, open the Main menu in the ACM (Automation Control Module) and select "Position Faders" from the "Faders" menu. The "Position Faders" dialog box will open.

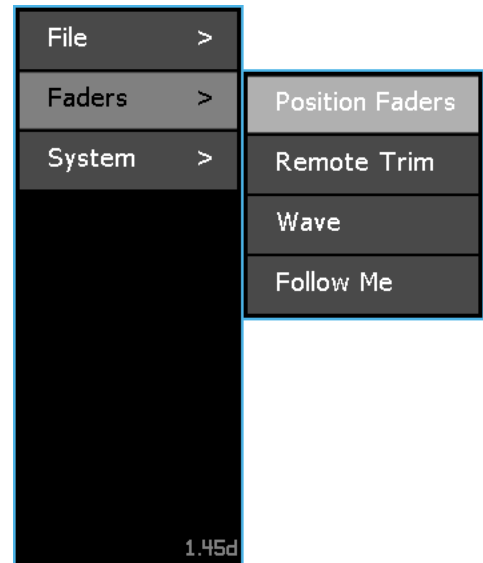

The "Position Faders" dialog box allows a specific fader position to be selected and applied to all faders or a specified set of faders.

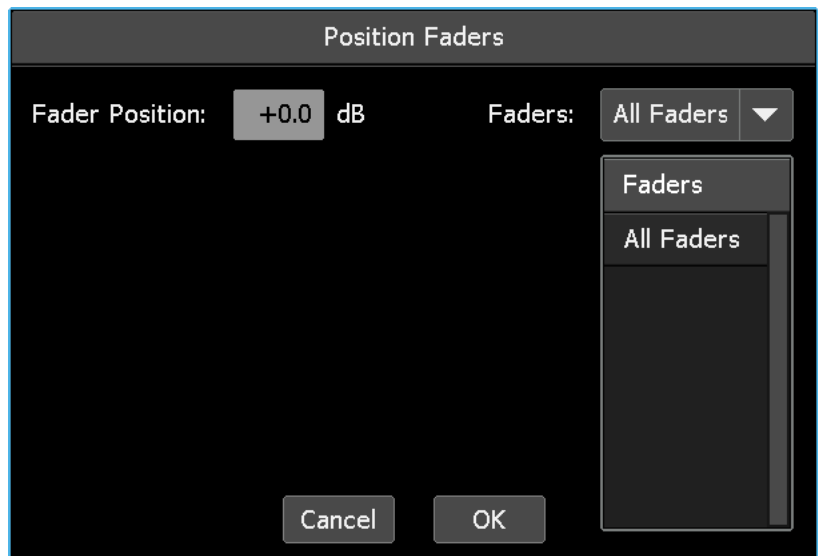

Select the faders to be positioned using the "Faders" pull-down menu. The menu choices are:

- **All**: All channels, Stereo Returns, Group Masters, and Program Masters
- **Selected**: A specified subset of faders



If "All" is selected, the Faders window will display "All Faders." This will include all Fader 1 and Fader 2 faders, as well as all program and group master faders.

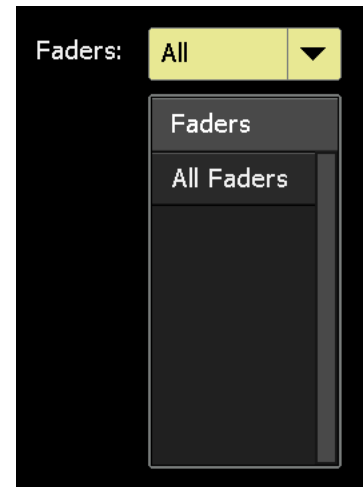

If "Selected" is chosen, the Faders window will display the faders that will be set to the specified position.

To select faders, touch the faders on channels to be positioned. Faders can be toggled in and out of the selection as long as the dialog box is open. To provide an audio alert, the beeper will sound each time a fader is selected.

As faders are selected, they will be displayed in the Faders window.

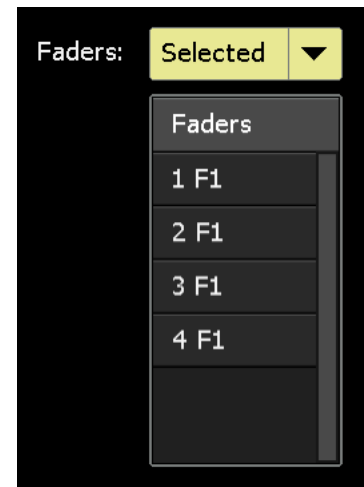

Press in the "Fader Position" field to activate its entry-field and enter the desired fader position in dB (decibels). Drag to scroll to the desired value in .5dB increments.

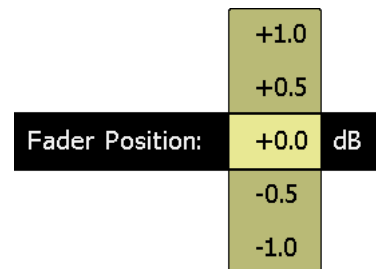

**OK** Once all the desired faders and specified fader position have been selected, press "OK" to move the selected faders to the specified position.

**WARNING:** Previous fader positions will be lost when the new positions are applied and this action cannot be undone.

**Cancel** Press "Cancel" to cancel.

Refer to section 20.1 Position Faders in the *Final Touch Automation*® manual for more information and operational details.

[https://www.apiaudio.com/docs/manuals/Final-Touch-Automation\\_user\\_2023-11-01.pdf](https://www.apiaudio.com/docs/manuals/Final-Touch-Automation_user_2023-11-01.pdf)

## 3.7 Channel Meters and Peak Indicators

For channel level indication, a routable VU meter is provided for each channel, along with a LED peak indicator for each audio path (Fader 1 and Fader 2).

### 3.7.1 Channel VU Meters

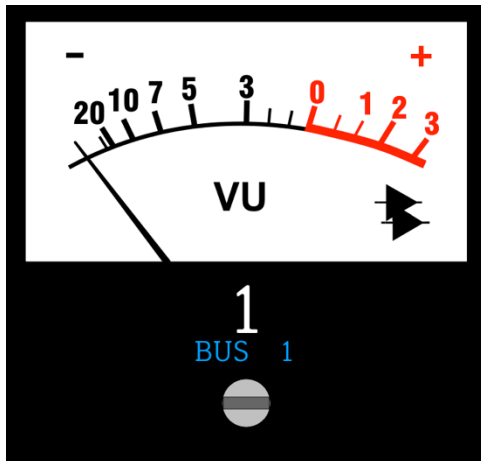

The channel VU meter can be fed from the following points:

- Fader 1 channel input
- Fader 2 channel input
- Direct output
- Multitrack summing buses 1-24

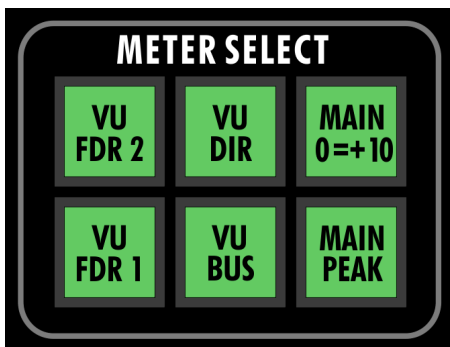

**METER SELECT:** The source feeding the channel VU meters is determined by the selection made using the **METER SELECT** controls in the center section.

The **METER SELECT** controls function as follows:



**VU FDR 2 (Fader 2):** Assigns the meters to the Fader 2 channel input

- Illuminates in green when engaged



**VU FDR 1 (Fader 1):** Assigns the meters to the Fader 1 channel input

- Illuminates in green when engaged



**VU DIR (Direct Output):** Assigns the meters to the channel direct output

- Illuminates in green when engaged



**VU BUS** (Multitrack Summing Buses 1-24): Assigns the meters 1-24 to the outputs of multitrack summing buses 1-24

- Illuminates in green when engaged

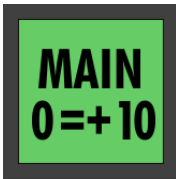

**MAIN VU 0 = +10**: Sets the main meters VU scale to 0VU equals +14dBu

- A -10dB pad is inserted before the meter
- 0VU equals +14dBu when engaged
- 0VU equals +4dBu when not engaged
- Illuminates in green when engaged



**MAIN VU PEAK**: Changes the main meter ballistics from VU to peak

- A fixed peak hold circuit feeds the meter
- Illuminates in green when engaged

### 3.7.2 1068L Channel Peak Indicators

Each 1068L is equipped with a LED peak indicator in each audio path, Fader 1 and Fader 2. The peak reference level is set by the **PEAK REFERENCE** control in the center section.



**PEAK**: The red LED illuminates when the **PEAK REFERENCE** level is reached in the respective audio path, Fader 1 or Fader 2

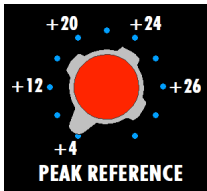

**PEAK REFERENCE**: Sets the peak reference level for all channel peak indicators (both audio paths)

- +4dBu to +28dBu Range
- Continuously variable potentiometer

# 3.8 Channel Patch Points

A comprehensive set of patch points associated with all *Vision+* channel audio paths (MIC PATH-Fader 2, LINE PATH-Fader 1) is provided and includes the following:

- Microphone tie-lines
- Upper 200L slots (preamp inputs and outputs)
- Lower 200L slots (dynamics inputs, side chain, and outputs)
- 500L EQ slot (equalization inputs and outputs)
- Fader 1 and Fader 2 insert (sends and returns)
- 1068L module inputs: Fader 1 and Fader 2 audio paths
- Direct outputs
- Primary multitrack recorder inputs and outputs
- Alternate multitrack recorder outputs
- EDAC connections for studio integration

## Channel Patch Bay

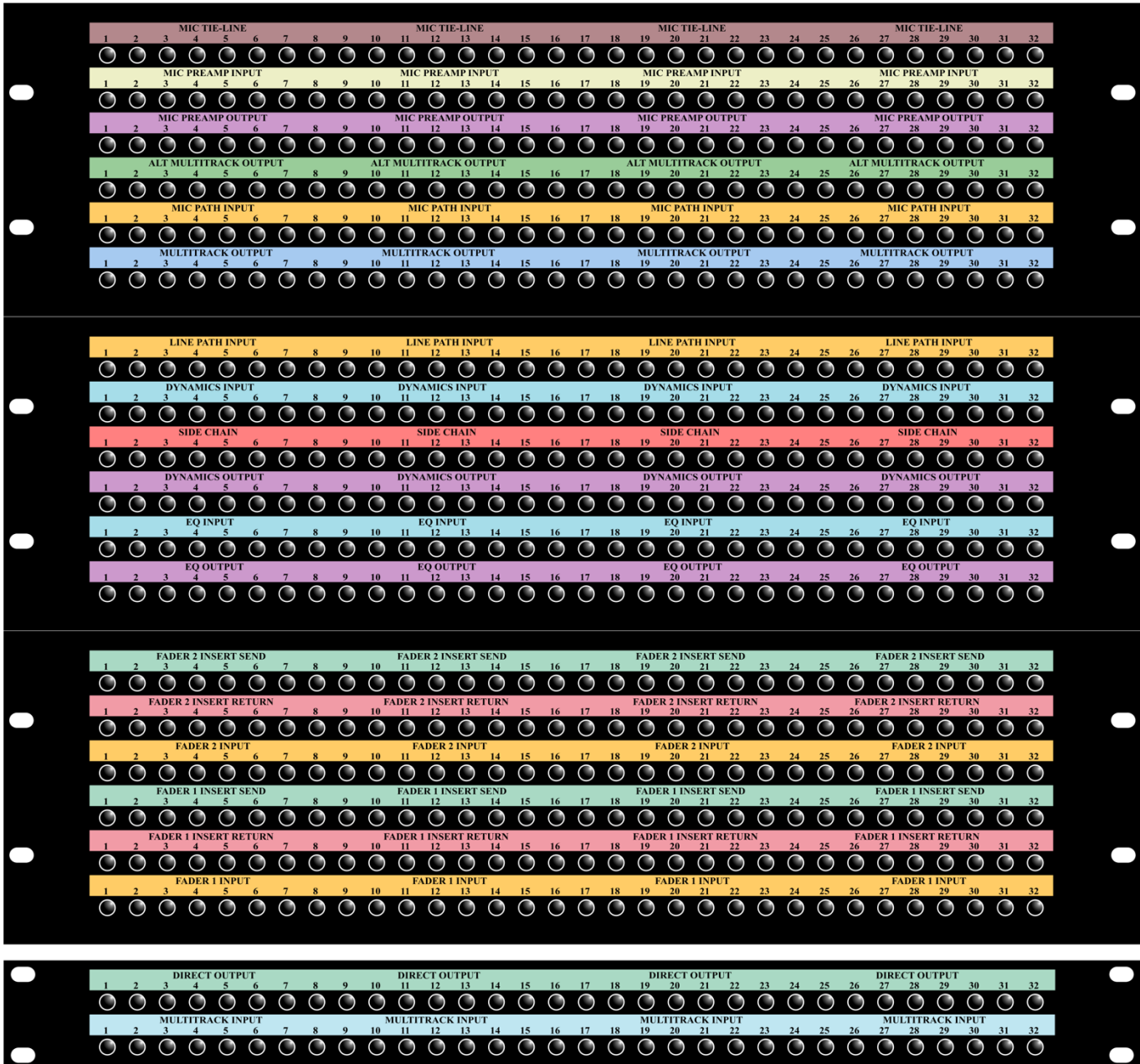

### 3.8.1 Patch Bay Normals

Patch bay “normals” are used to facilitate typical signal through the console and studio. For example, the DIRECT OUTPUT patch points are “normally” patched to the MULTITRACK INPUTS for most applications, so the patch bay is internally wired to make this and other normally used connections so extensive patching can be avoided.

Two types of patch bay normals are employed: half-normals and full-normals. The behavior of each is determined by their application and are describe as follows:

Half-Normalled Outputs: All line-level output patch points are half-normalled to their functional destinations. Their signals are “split” when a patch cord is inserted. In other words, when a patch cord is inserted in a line-level output, the signal is available at the patch cord, but it also continues to its normalled destination, in essence creating a “Y-cord.”

Full-Normalled Outputs: Only the MIC TIE-LINE patch points are full-normalled to their functional destinations, the MIC PREAMP INPUTS. Their signals are “broken” when a patch cord is inserted. In other words, when a patch cord is inserted in a MIC TIE-LINE, the signal is available at the patch cord, but does not continue to the MIC PREAMP INPUTS.

*NOTE: The MIC TIE-LINE patch points are the only patch points that “break” when a patch cord is inserted.*

Normalled Inputs: All normalled input patch points “break” when a patch cord is inserted. In other words, the signal is received from the inserted patch cord and does not get its signal from its normalled source. The connection with its normalled source is broken.

### 3.8.2 Channel Patch Point Details and Normals

The following section outlines the channel patch points for each audio path in default signal flow order.

*IMPORTANT NOTE: To accommodate the space restrictions of this manual, only the first eight (8) Patch Points are shown for each row and a smaller font is used in the following section. The total number of channel points in an actual patch bay will is determined by frame size. For example, the channel bays for a 48-channel frame will accommodate 48 sets of channel patch points.*

#### 3.8.2.1 Mic Path and Fader 2 Patch Points

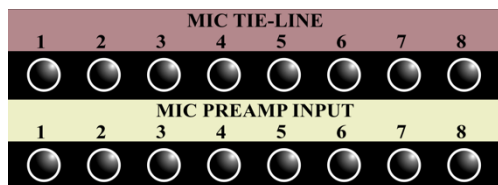

MIC TIE LINE: Studio microphone tie-line outputs

- Fully-normalled to MIC PREAMP INPUT
- EDAC connection for studio integration

MIC PREAMP INPUT: Upper 200L slot module input

- Fully-normalled from MIC TIE LINE
- Patching will replace the MIC TIE-LINE feed to the preamp
- **CAUTION:** Can carry 48v phantom power

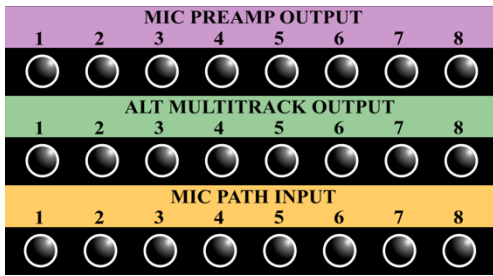

**MIC PREAMP OUTPUT:** Upper 200L slot module output

- Half-normalled to MIC PATH INPUT

**ALT MULTITRACK OUTPUT:** Alternate DAW/multitrack output

- Replaces MIC PATH signal when **ALT LINE** switch is engaged
- EDAC connection for studio integration

**MIC PATH INPUT:** Input to the MIC PATH front-end signal flow

- Feeds the Fader 2 audio path by default
- Also selectable as the Fader 1 audio path input
- Feeds DYNAMICS INPUT by default

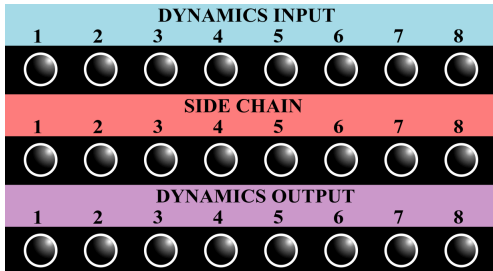

**DYNAMICS INPUT:** Lower 200L slot module input (often 225L Compressor)

- Fed from Fader 2 mic/**LINE** switch
- Half-normalled to SIDE CHAIN

**SIDE CHAIN:** Lower 200L slot module side chain or key input

- Half-normalled from DYNAMICS INPUT

**DYNAMICS OUTPUT:** Lower 200L slot module output

- Feeds the FADER 2 INSERT SEND in the Mic Path

*NOTE: Engaging the **DYN TO FDR1** switch will move the lower 200L slot to the LINE PATH (Fader 1) before the EQ.*

*NOTE: Patching into the **SIDE CHAIN** input will replace the **DYNAMICS INPUT** as the source for the module's detection path (side-chain).*

*NOTE: When a 225L Compressor/Limiter is installed in the lower 200L slot, the **SIDE CHAIN** patch point is only active when the **NEW TYPE** is selected. This is due to path to the detector circuit being fed after the gain reduction element (VCA) when **OLD TYPE** is selected.*

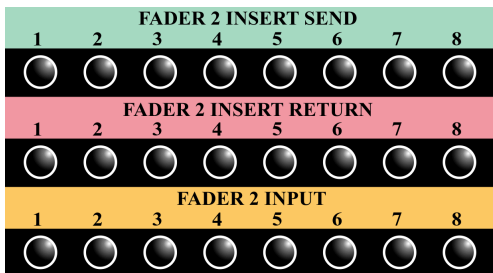

**FADER 2 INSERT SEND:** Fader 2 insert send (always active)

- Half-normalled from DYNAMICS OUTPUT
- Feeds FADER 2 INPUT when the Fader 2 **INS** switch *is not* engaged

**FADER 2 INSERT RETURN:** Fader 2 insert return

- Half-normalled from FADER 2 INSERT SEND
- Feeds channel FADER 2 INPUT when the Fader 2 **INS** switch *is* engaged

**FADER 2 INPUT:** 1068L Fader 2 input

- Half-normalled from FADER 2 INSERT SEND/RETURN

### 3.8.2.2 Line Path and Fader 1 Patch Points

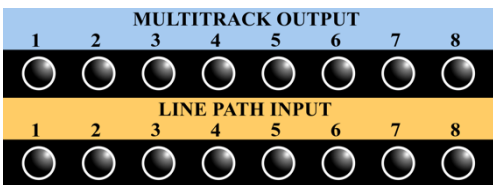

**MULTITRACK OUTPUT:** Primary DAW/multitrack output (multitrack return)

- Half-normalled to the LINE PATH INPUT patch point
- EDAC connection for studio integration

**LINE PATH INPUT:** Input to the LINE PATH front-end signal flow

- Feeds the Fader 1 audio path by default
- Also selectable as the Fader 2 audio path input
- Feeds EQ INPUT by default

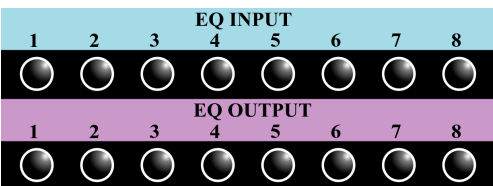

**EQ INPUT:** 500L EQ slot module input

- Fed from Fader 1 line/**MIC** switch

**EQ OUTPUT:** 500L EQ slot module output

- Feeds the FADER 1 INSERT SEND in the Line Path

*NOTE: Engaging the **EQ FDR2** switch will move the 500L EQ slot to the MIC PATH (Fader 2) after the lower 200L slot.*

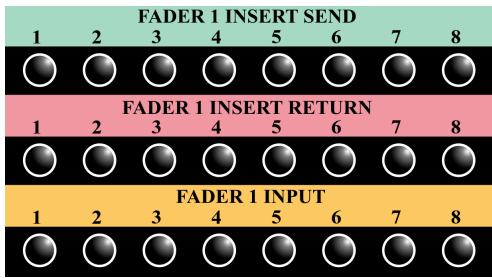

FADER 1 INSERT SEND: Fader 1 insert send

- Half-normalled from DYNAMICS OUTPUT
- Feeds FADER 1 INPUT when the Fader 1 **INS** switch *is not* engaged Always active
- Always active

FADER 1 INSERT RETURN: Fader 1 insert return

- Half-normalled from FADER 1 INSERT SEND
- Feeds channel FADER 1 INPUT when the Fader 1 **INS** switch *is* engaged

FADER 1 INPUT: 1068L Fader 1 input

- Half-normalled from FADER 1 INSERT SEND/RETURN

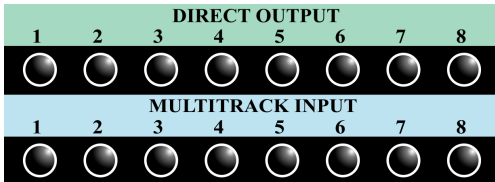

DIRECT OUTPUT: Channel direct output

- Fed from FADER 1 by default
- Will be fed from Fader 2 if the **DIR FDR2** switch is engaged
- Half-normalled to MULTITRACK INPUT

MULTITRACK INPUT: DAW/multitrack recorder input (multitrack send)

- Half-normalled from DIRECT OUTPUT
- EDAC connection for studio integration

# 4.0 Channel Output Routing

The output of each audio path (Fader 1 and Fader 2) may be routed to the following destinations:

- Channel direct output
- Multitrack summing buses 1-24
- Stereo program bus A
- Stereo program bus B
- Stereo program bus C
- Surround program bus

*IMPORTANT NOTE: If no output assignments have been made, the output of the Fader 1 will feed the direct output and the Fader 2 will not be routed anywhere.*

In a simple tracking session, it is typical for Fader 2 to be assigned to the direct output or a multitrack summing bus and Fader 1 to feed the Stereo A (STA) program bus. In a simple mixing session, Fader 1 remains assigned to feed the Stereo A (STA) program bus, but in more complex mixes, it is typical for both paths on most channels to be assigned to one or more Program Bus (Stereo A, B, C, and/or Surround). The Fader 2 audio path may be used as addition multitrack, virtual, or effects returns and/or to create additional sends during a mix. Fader 2 might also be used to create a LFE send for a surround mix.

The direct output will be fed from the output of the Fader 1 by default. It may alternatively be fed from Fader 2 when the **DIR FDR2** switch on the 1068L input module is engaged. The direct output cannot be fed from both audio paths simultaneously.

Assignments to the multitrack summing buses can be made from only one audio path at a time (Fader 1 or Fader 2). In other words, the multitrack summing buses cannot be accessed from both paths simultaneously.

Assignments to any or all program buses may be made from both paths simultaneously. This allows both the Fader 1 and Fader 2 audio paths to contribute to the program buses during mix down. This means a *Vision+* console with 48 channels provides 96 automated channels with surround panning while mixing (not counting any E1068L effects return modules).

Assignments to the multitrack summing and program buses may be made in two ways:

- Hardware: Using the 16-channel output assignment module
- Software: Using the *Final Touch Automation*<sup>®</sup> routing and snapshot systems

Input assignments may also be stored and recalled using the snapshot system

Section 4.1 will explain how to assign the direct output.

Section 4.2 will explain how to make output assignments using the 16-channel output assignment modules.

Section 4.3 will explain how to make output assignments using the routing and snapshot systems in the *Final Touch Automation*<sup>®</sup> software.

# 4.1 Channel Direct Output

The channel direct output may be fed from the output of the Fader 1 or Fader 2 audio paths, but not both simultaneously.

The direct output is fed from the Fader 1 path output by default. It may be fed from the Fader 2 path if the **DIR FDR2** switch is engaged on the 1068L V3 input module.



**DIR FDR2 (Direct Output Fader 2):** Routes the output of Fader 2 audio path to the direct output

- Direct output is fed POST the MUTE switch
- Direct output is fed from Fader 1 by default
- Feeds the DIRECT OUTPUT patch point, which is half-normalled to the MULTITRACK INPUT patch point
- Routing/Snapshot control
- Illuminates when engaged

*NOTE: There is not a direct output switch for Fader 1. The **DIR FDR2** switch is included with the Fader 2 controls and toggles the direct output from one fader output or the other. When the **DIR FDR2** switch is not engaged, the direct output is fed from Fader 1.*

The direct output feeds the DIRECT OUTPUT patch points.

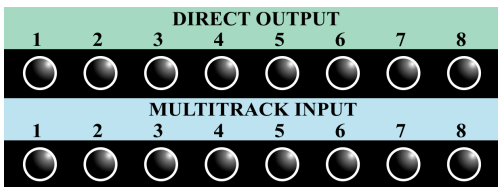

**DIRECT OUTPUT:** Channel direct output

- Fed from FADER 1 by default
- Will be fed from Fader 2 if the **DIR FDR2** switch is engaged
- Half-normalled to MULTITRACK INPUT

**MULTITRACK INPUT:** DAW/multitrack recorder input (multitrack send)

- Half-normalled from DIRECT OUTPUT
- EDAC connection for studio integration

# 4.2 Channel Output Assignment Module

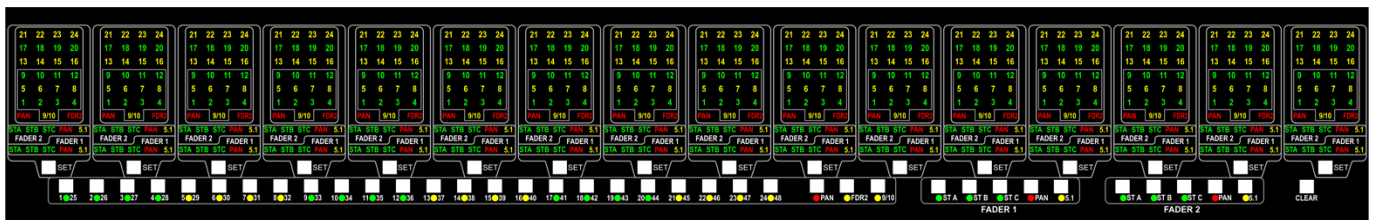

There is one (1) channel output assignment module for every 16-channel bucket. This output assignment module supports the sixteen channels installed in its bucket.

The output assignment module allows the assignment of the Fader 1 and Fader 2 outputs to the following multitrack summing and program buses:

- Multitrack summing buses 1-24
- Stereo program bus A
- Stereo program bus B
- Stereo program bus C
- Surround program bus

## 4.2.1 Channel Output Assignment Display

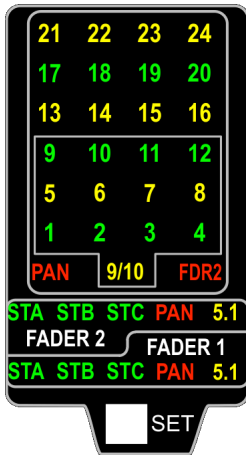

There is a output assignment display for every channel. It displays the current output routing assignments for the Fader 1 and Fader 2 audio paths:

- Multitrack summing bus assignments (1-24)
- Stereo program bus assignments (ST A, ST B, ST B)
- Surround program bus assignments (5.1)
- Pan-pot assignment
- Auxiliary send 9/10 assignments

When assignments are made, the associated indicator illuminates.

**SET:** Assigns the associated channel to the selections made using the bus assignment switches

- Press and release to assign selections
- Long-press (press and hold) to restore current assignments to the display and selector switches

*NOTE: Current channel output assignments will be reset whenever the **SET** switch is pressed and released and the current selections will be assigned. To avoid inadvertent loss of current assignments when adding new assignments, press and hold the **SET** switch to restore current output assignments before adding new ones.*

## 4.2.2 Multitrack Summing Bus Assignments

Channel output assignments may be made to any of the twenty-four (24) multitrack summing buses (1-24).

Multitrack summing bus assignments are made in the multitrack routing section of the output assignment module. Assignment and routing switches provide full access to the multitrack summing buses from Fader 1 or Fader 2.

*NOTE: The multitrack summing buses cannot be accessed from both channel audio paths (Fader 1 and Fader 2) simultaneously.*



The assignment switches in the multitrack routing section of the output assignment module function as follows:



1 thru 24 (Multitrack Summing Bus): Readies the selected multitrack summing buses for assignment

- Channel assignments are not made until a channel **SET** switch is pressed
- A green or yellow LED indicator illuminates when selected



**PAN:** Readies the pan-pot for assignment

- Facilitates odd/even panning to the multitrack summing buses
- Assignments are not made until a channel **SET** switch is pressed
- A red LED indicator illuminates when selected



**FDR2 (Fader 2):** Selects the output of Fader 2 as the source for multitrack summing bus assignments

- The multitrack summing buses are fed from Fader 1 by default
- Assignments are not made until a channel **SET** switch is pressed
- A yellow LED indicator illuminates when selected



**9/10 (Auxiliary Send 9/10):** Selects stereo auxiliary send 9/10 as the source when assignments are made

- Allows auxiliary send 9/10 to feed multitrack summing buses 1-8
- Assignment to the desired multitrack summing buses must be made
- Assignments are not made until the channel **SET** switch is pressed
- A yellow LED indicator illuminates when selected

*NOTE: When auxiliary sends 9/10 are routed to the multitrack summing buses, the feed to auxiliary bus 9/10 from that channel is defeated.*

### 4.2.3 Program Bus Assignments

Channel output assignments may be made to three (3) stereo program buses and one (1) set of surround program buses.

Both audio paths, Fader 1 and Fader 2, may feed all program buses simultaneously.



The Fader 1 and Fader 2 audio paths each have a program bus assignment section. Assignments may be made to the following program buses:

- ST A: Stereo A
- ST B: Stereo B
- ST C: Stereo C
- 5.1: Surround



For stereo panning, the pan-pots in each path may also be engaged using the **PAN** switch.

The assignment switches in the Fader 1 and Fader 2 program bus routing sections of the output assignment module function as follows:

*NOTE: The program bus assignment switches for Fader 1 and Fader 2 operate identically, so only one set of assignment switches is shown here.*



**ST A (Stereo A):** Readies stereo program bus A for assignment

- Assignments are not made until a channel **SET** switch is pressed
- A green LED indicator illuminates when selected



**ST B (Stereo B):** Readies stereo program bus B for assignment

- Assignments are not made until a channel **SET** switch is pressed
- A green LED indicator illuminates when selected



**ST C (Stereo C):** Readies stereo program bus C for assignment

- Assignments are not made until a channel **SET** switch is pressed
- A green LED indicator illuminates when selected



**PAN:** Readies the Left/Right pan-pot for assignment to the stereo program buses

- Facilitates Left/Right panning to the assigned program buses
- Assignments are not made until a channel **SET** switch is pressed
- A red LED indicator illuminates when selected

*NOTE: The Fader 1 and Fader 2 stereo pan-pots are not engaged by default and must be activated when output assignments are made.*

*NOTE: The Fader 1 and Fader 2 Pan-pots always feed the surround program bus.*



**5.1 (Surround):** Readies the surround program bus for assignment

- Feeds L, R, C, SI, and Sr program buses
- Does not feed the LFE filter or A/B program buses
- Surround pan-pots are always active
- Assignments are not made until a channel **SET** switch is pressed
- A yellow LED indicator illuminates when selected



**CLEAR:** Clears/sets all assignment selectors

- Press and release to clear all current assignment selections
- Long-press (press and hold) to set all assignment selections

## 4.2.4 Multitrack Summing Bus Assignment Procedure

To assign channels to multitrack summing buses, perform the following procedure:

1. Press **CLEAR** to clear any previous assignment selections.

**OR**

Long-press **SET** on a channel to load current the channel assignments to the switches.

2. Press **FDR2** (Fader 2) if the assignments are to be fed from Fader 2.
3. Press the **PAN** assignment switches if necessary (for odd/even panning).
4. Press the assignment switches for the desired multitrack summing bus(es) to select them for assignment.
5. Press the **SET** switch on the channels to be assigned.

*NOTE: The multitrack summing buses cannot be accessed from both channel audio paths (Fader 1 and Fader 2) simultaneously.*

## 4.2.5 Program Bus Assignment Procedure

To assign channels to program buses, perform the following procedure:

1. Press **CLEAR** to clear any previous assignment selections.

**OR**

Long-press **SET** on a channel to load current the channel assignments to the switches.

2. Press the **PAN** assignment switches for stereo panning.
3. Press the assignment switches for the desired program bus(es) to select them for assignment.
4. Press the **SET** switch on the channels to be assigned.

## 4.2.6 Aux 9/10 to Multitrack 1-8 Assignment Procedure

To assign auxiliary sends 9/10 to multitrack summing buses 1-8, perform the following procedure:

1. Press **CLEAR** to clear any previous assignment selections.

**OR**

Long-press **SET** on a channel to load current the channel assignments to the switches.

2. Press the **9/10** assignment switch to select stereo auxiliary sends 9/10 to feed multitrack summing buses 1-8.
3. Press the assignment switches for the desired multitrack summing buses (1-8 only) to select them for assignment.
4. Press the **SET** switch on the channels to be assigned.

*NOTE: When aux sends 9/10 are routed to the multitrack summing buses, the feed to auxiliary bus 9/10 from that channel is defeated.*

## 4.3 Channel Setup and Routing Via Software

Vision+ consoles are equipped with API's *Final Touch Automation*® system, which provides channel control setup and output routing via software. This is accomplished by using the Channels page and the Routing page on the automation control module (ACM) in combination.

The positions of the following switches may be set using the routing system and stored and recalled using the snapshot system:

### Channel:

- **EQ TO FDR2** (EQ to Fader 2)
- **DYN TO FDR1** (Dynamics to Fader 1)
- **ALT LINE** (alternate multitrack output)
- **Pan to 24** (Odd/even panning to multitrack summing buses)
- **9/10 to 1-8** (Aux 9/10 to multitrack summing buses 1-8)
- **F2 to 24** (Fader 2 to multitrack summing buses)
- **DIR FDR2** (Fader 2 to direct output)

### Fader 1:

- Fader position (snapshot only)
- 0dB bypass (long-press Ø)
- Solo **SAFE**
- Ø (polarity inverter)
- **FILT** (high-pass filter)
- **STA, STB, STC, 5.1** (program bus assignment)
- **PAN** (stereo pan-pot engage)
- **LCR** (Left, Center, Right front surround panning)
- **MIC** (MIC PATH input)
- **2=1** (Fader 2 follows Fader 1 position)

### Fader 2:

- Fader position (snapshot only)
- 0dB bypass (long-press Ø)
- Solo **SAFE**
- Ø (polarity inverter)
- **FILT** (high-pass filter)
- **STA, STB, STC, 5.1** (program bus assignment)
- **PAN** (stereo pan-pot engage)
- **LCR** (Left, Center, Right front surround panning)
- **LINE** (LINE PATH input)
- **FDR1** (Fader 2 input feed from Fader 1 output)

### Auxiliary Send Routing:

The following auxiliary send and global routing options may be set, stored, and recalled using the routing or snapshot systems:

- Auxiliary Send 1 **ON/off**
- Auxiliary Send 2 **ON/off**
- Send 1/2 -> PRE
- Send 1/2 -> FDR 2
- Auxiliary Send 3 **ON/off**

- Auxiliary Send 4 **ON**/off
- Send 3/4 -> PRE
- Send 3/4 -> FDR 2
- Auxiliary Send 5 **ON**/off
- Auxiliary Send 6 **ON**/off
- Send 5/6 -> PRE
- Send 5/6 -> FDR 2
- Auxiliary Send 7/8 **ON**/off
- Auxiliary Send 9/10 **ON**/off
- Send 7/8 and 9/10 -> PRE
- Send 7/8 and 9/10 -> FDR 2
- 9/10 to Bus 1-8

*NOTE: Auxiliary sends 9/10 follow the same routing as auxiliary sends 7/8.*

Multitrack Bus Assignments:

- 1-24

To assign channel control settings and output destinations, first access the Channels page in the ACM by pressing the Channels tab on the second display. Select the channel(s) for assignment by pressing on them using the channel grid.

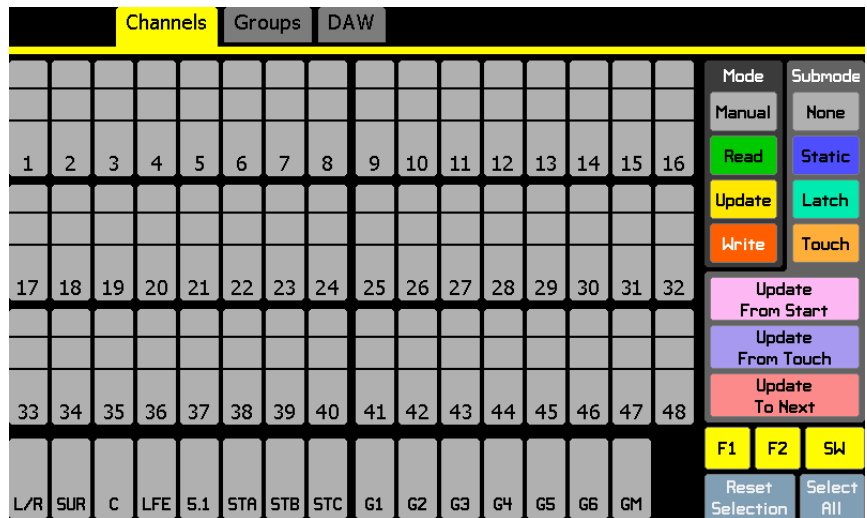

Once the channel(s) have been selected, open the Routing page, but pressing the Routing tab on the main display.

Press the controls to be set and/or the needed output assignments on the Routing page. These selections will be applied to the channels selected on the Channels page.

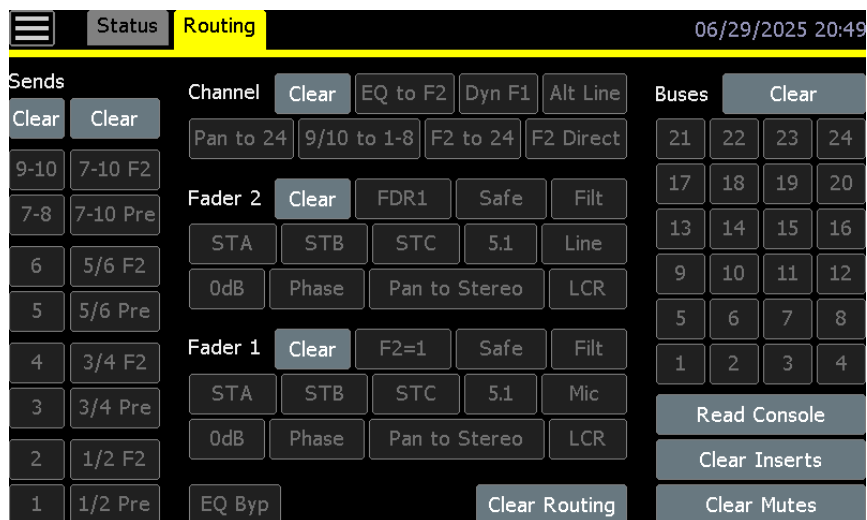

*NOTE: It may be preferable to assign common channel control settings to many channels as a first step before making multitrack bus assignments for individual channels.*

Refer to sections 18.0 Snapshots and 21.2 Vision Routing and Snapshots in the *Final Touch Automation*® manual for more information about routing, snapshots, and operational details. [https://www.apiaudio.com/docs/manuals/Final-Touch-Automation\\_user\\_2023-11-01.pdf](https://www.apiaudio.com/docs/manuals/Final-Touch-Automation_user_2023-11-01.pdf)

# 5.0 Multitrack Summing Buses

DAWs and other multitrack recorders receive their input signals in one of two ways:

- **Direct Outputs**: Non-summing output direct from individual channels
- **Multitrack Summing Bus Outputs**: Multitrack summing bus outputs 1-24

Direct outputs are a mono only, single-source to the multitrack directly from the channel, without summing. Direct outputs have the advantage of a short, minimal audio signal path.

Multitrack summing bus outputs have the ability to blend together sources from multiple input channels and route them to one or more tracks. The pan-pot can be assigned to provide odd/even stereo panning to a pair of tracks.

This section will discuss the multitrack summing buses and signal flow in detail.

## 5.1 Multitrack Summing Buses

Vision+ consoles are twenty-four (24) multitrack summing buses:

- 1-24

Multitrack summing buses 1-24 may be fed the following sources:

- Fader 1 output
- Fader 2 output

*NOTE: The multitrack summing buses cannot be accessed from both channel audio paths (Fader 1 and Fader 2) simultaneously.*

Multitrack summing buses 1-8 may also be fed from stereo auxiliary sends 9/10.

*NOTE: When auxiliary sends 9/10 are routed to the multitrack summing buses, the feed to auxiliary bus 9/10 from that channel is defeated.*

Multitrack summing bus assignments may be made:

- Locally on the 16-channel output assignment module (1-24 switches)
- Via the *Final Touch Automation*<sup>®</sup> routing system

Each of the multitrack summing bus assignments is internally routed to its respective multitrack summing bus. The output of these buses is fed to the corresponding multitrack output module in the center section.

*NOTE: A multitrack recorder may alternately be fed from the channel direct outputs by patching the DIRECT OUT patch points to the desired multitrack recorder input interface.*

## 5.2 Multitrack Output Modules

Each multitrack summing bus feeds a multitrack output module just before its BUS OUTPUT patch points.

The multitrack output modules are located in the center section.

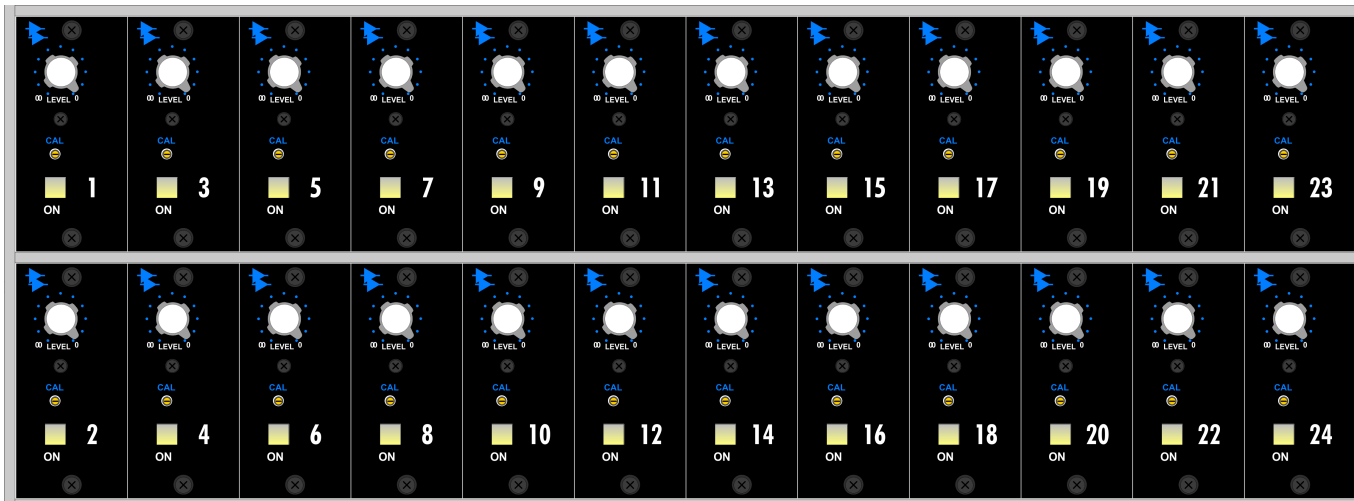

### 5.2.1 Multitrack Output Controls

Controls for the multitrack output modules are as follows:

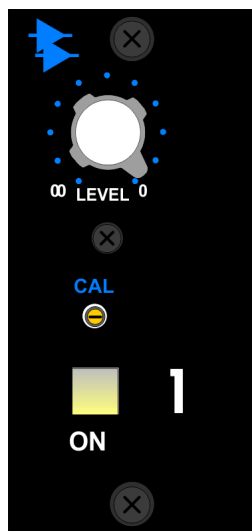

**LEVEL:** Sets the amount of trim (attenuation) for the multitrack output

- $-\infty$  to 0dB range
- 0dB is unity gain
- $-\infty$ dB is full attenuation

**CAL:** Trim pot for 0dB calibration

**ON (On/off switch):** Activates the multitrack output

- Illuminates when engaged

The output of the multitrack output modules feed the BUS OUT patch points. These patch points are half-normalled to the MULTITRACK IN patch points.

# 5.3 Multitrack Patch Points

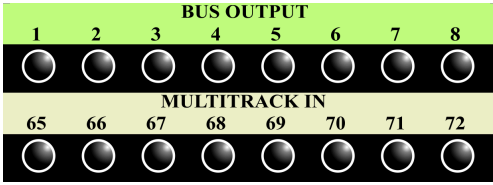

**BUS OUTPUT:** Multitrack summing bus outputs

- Half-normalled to MULTITRACK IN

**MULTITRACK IN:** Input to the multitrack recorder(s)

- Half-normalled from BUS OUTPUT
- Patching to these points will replace the feed to the multitrack recorder with the patch cord signal
- EDAC connection for studio integration

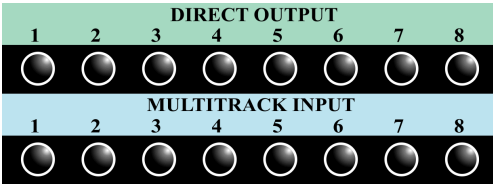

**DIRECT OUTPUT:** Channel direct output

- Fed from FADER 1 by default
- Will be fed from Fader 2 if the **DIR FDR2** switch is engaged
- Half-normalled to MULTITRACK INPUT

**MULTITRACK INPUT:** DAW/multitrack recorder input (multitrack send)

- Half-normalled from DIRECT OUTPUT
- EDAC connection for studio integration

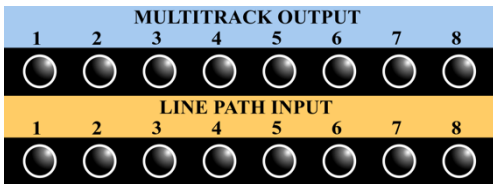

**MULTITRACK OUTPUT:** Primary DAW/multitrack output (multitrack return)

- Half-normalled to the LINE PATH INPUT patch point
- EDAC connection for studio integration

**LINE PATH INPUT:** Input to the LINE PATH front-end signal flow

- Feeds the Fader 1 audio patch by default
- Also selectable for as the Fader 2 input
- Feeds EQ INPUT



**ALT MULTITRACK OUTPUT:** Alternate DAW/multitrack output

- Replaces MIC PATH signal when **ALT LINE** switch is engaged
- EDAC connection for studio integration

# 5.4 Multitrack Summing Bus Signal Flow

The diagram below shows the basic multitrack summing bus signal flow. Only the first eight patch points are shown for each row.

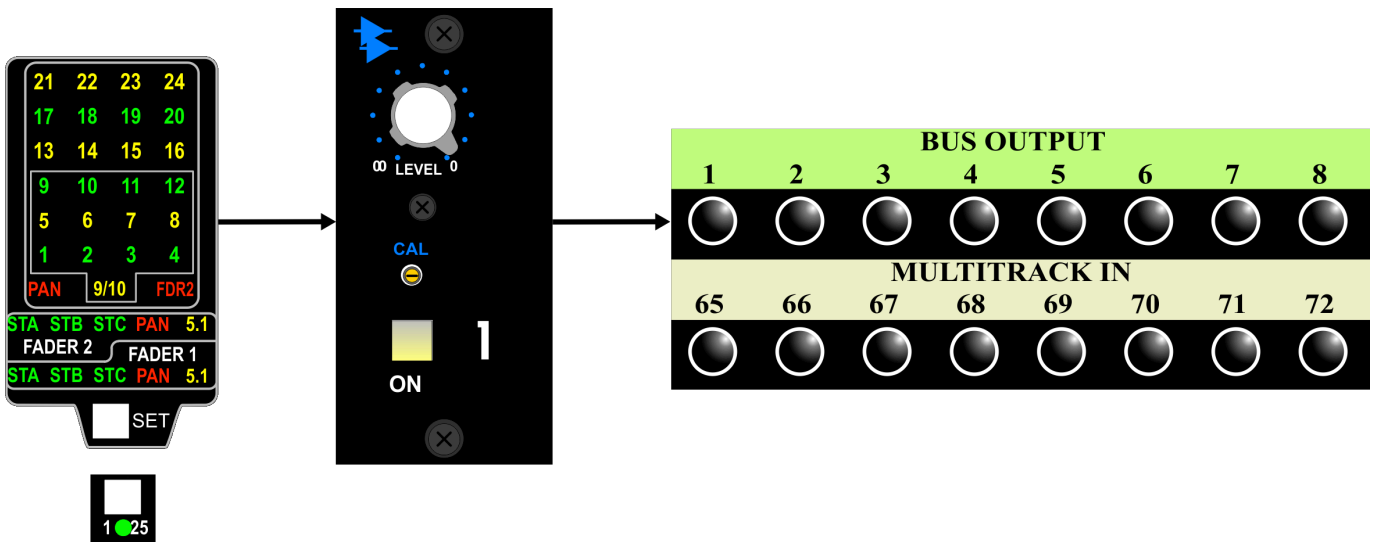

# 6.0 Stereo Program Masters

*Vision+* consoles are equipped with four (4) independent, full-featured, left-right stereo program masters:

- **ST A**: Stereo program bus A
- **ST B**: Stereo program bus B
- **ST C**: Stereo program bus C
- **GM**: Stereo program grand master bus

The three stereo masters can be combined to the grand master (**GM**) bus, along with an external input and the Lt Rt fold-down, to facilitate easy sub-mixing, parallel processing, and other applications. Stereo bus compression can also be applied with an optional 2500+C Bus Compressor.

It should be noted that the stereo program masters are separate and fully independent from the surround program masters, so unlike other console architectures, the stereo program buses are not needed for surround mixing. So, simultaneous mixing to all three stereo program masters and the surround program masters is possible and not functionally compromised. A real-time fold-down of the surround mix to a stereo Lt Rt mix is also possible. Surround mixing and fold-down will be covered in subsequent sections.

The structure of the stereo program masters include the three stereo buses, their associated active combining amplifiers (ACA), output modules, automated master faders, and a comprehensive set of patch points.

This program bus architecture, combined with a comprehensive set of program bus output modules and patch points provides many routing capabilities including:

- Three independent stereo mixes with simultaneous outputs
- Summed stereo grand master output
- Stereo bus compression with an optional 2500+C Bus Compressor
- Parallel processing
- Sub-mixing and processing
- Stem mixing
- Mix minus stems (clean channel feed)
- Simultaneous surround and stereo mixing
- Surround to stereo fold-down
- Other applications

## 6.1 Stereo Program Buses A, B, and C

As mentioned above, *Vision+* consoles have three (3) independent stereo program buses:

- **ST A**: Stereo program bus A
- **ST B**: Stereo program bus B
- **ST C**: Stereo program bus C

The Fader 1 and Fader 2 outputs of all 1068L channel input modules can be independently routed to these program buses, so up to three separate stereo mixes may be created simultaneously.

To activate Left-Right panning the following conditions must be met:

- The channel must be assigned to one or more of the stereo program buses (**ST A**, **ST B**, and/or **ST C**)
- The pan-pot (**PAN**) must be engaged in the assignment section

The 1068L modules feed the stereo program buses as assigned, (ST A, ST B, and/or ST C). These buses feed their associated active combining amplifiers (ACA).

The patch points from the stereo bus ACA outputs (STEREO ACA OUTPUTS) are half-normalled to the stereo master fader inputs (STEREO FADER INPUTS).

Signals from the STEREO SUM BUS ACCESS IN patch points will be added the bus feed from the channels before the ACA.

Boosters calibrate the outputs of each stereo master fader. The outputs of the stereo master fader boosters (STEREO BSTR OUT) feed the stereo program output modules. These modules contain an **ON**/off switch and **CAL** trim pot to calibrate the master fader booster for each output. **The STEREO BSTR OUT patch points are the main stereo mix outputs from the console.**

The booster output patch points (STEREO BSTR OUTPUTS) are half-normalled to the external 2-track recorder input patch points as follows:

- STEREO BSTR OUTPUTS ST A (L-R) are half-normalled to 2T1 IN (L-R): 2-track 1 input
- STEREO BSTR OUTPUTS ST B (L-R) are half-normalled to 2T2 IN (L-R): 2-track 2 input
- STEREO BSTR OUTPUTS ST C (L-R) are half-normalled to 2T3 IN (L-R): 2-track 3 input
- GM BSTR OUT (L-R) are half-normalled to 2T4 IN (L-R): 2-track 4 input

*NOTE: Patching is required to record a mix to more than one external 2-track recorder.*

Stereo program bus assignments from 1068L input modules may be made:

- Locally on the 16-channel output assignment modules (**ST A**, **ST B**, **ST C** switches)
- Via the *Final Touch Automation*<sup>®</sup> Routing/Snapshot control

## 6.2 Stereo Grand Master

A stereo grand master summing bus is provided to facilitate a wide range of applications including sub-mixing and processing, stereo stem mixing, mix minus stems (clean channel feed) and other operations.

The structure of the grand master output includes the grand master source selectors (GRAND MASTER SELECT), stereo grand master bus, the associated active combining amplifiers (ACA), output module, automated master fader, and a comprehensive set of patch points.

## 6.2.1 Grand Master Select

The up to five (5) stereo sources can be selected for stereo grand master summing. These sources are assigned with the **GRAND MASTER SELECT** selectors in the center section.

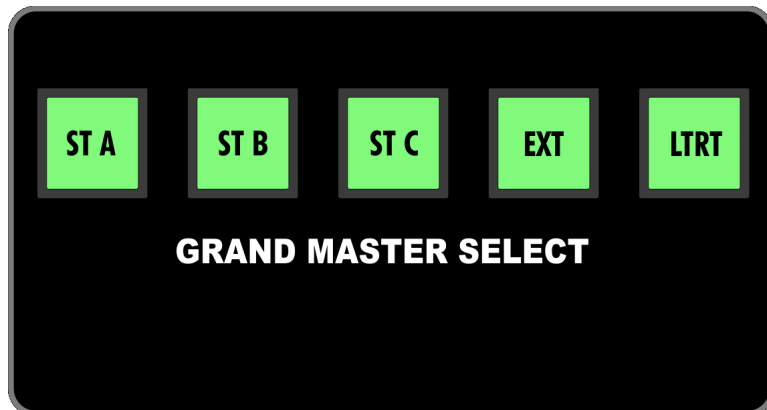

The stereo grand master may be fed from the following stereo sources:

- **ST A:** Stereo A BSTR OUTPUTS
- **ST B:** Stereo B BSTR OUTPUTS
- **ST C:** Stereo C BSTR OUTPUT
- **EXT:** EX GM IN patch points
- **LTRT:** Lt Rt fold-down matrix

The controls for the Grand Master Select function as follows:



**ST A (Stereo A):** Routes the output of the stereo A output module to the grand master bus

- Illuminates when engaged



**ST B (Stereo B):** Routes the output of the stereo B output module to the grand master bus

- Illuminates when engaged



**ST C (Stereo C):** Routes the output of the stereo C output module to the grand master bus

- Illuminates when engaged



**EXT (External):** Routes the output of the stereo GM EXT IN patch points to the grand master bus

- Illuminates when engaged



**LTRT (Left-total and Right-total):** Routes the output of the Left-total and Right-total fold down matrix to the grand master bus

- Illuminates when engaged

The selected grand master sources are routed to the grand master summing bus and mixed together at the GM ACA to create a grand master stereo program.

The patch points from the grand master ACA outputs (GM ACA OUT L-R) are half-normalled to the stereo grand master fader inputs (GM FDR IN L-R).

The grand master booster output patch points (GM BSTR OUT) are half-normalled to 2T4 IN (L-R): 2-track 4 input

*NOTE: Patching is required to record a mix to more than one external 2-track recorder.*

## 6.3 Stereo Program Master Faders

Vision+ consoles are equipped with three (3) stereo master faders and one (1) grand master fader. All have automation control.

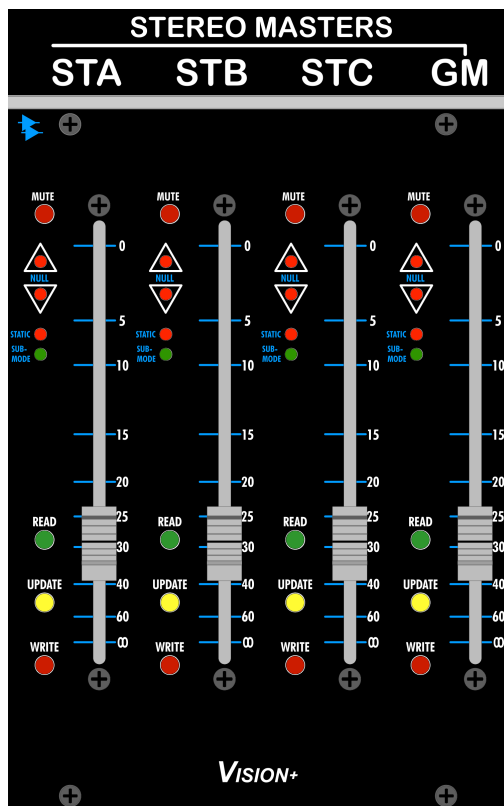

Stereo program master faders and sources:

- **ST A:** Stereo A ACA OUTPUTS
- **ST B:** Stereo B ACA OUTPUTS
- **ST C:** Stereo C ACA OUTPUTS
- **GM:** Grand Master ACA OUTPUTS

**STA, STB, STC, GM:** Stereo master faders that are the primary level control the main stereo program outputs

- 0dB is unity gain
- Automation control
  - Full-sized 100mm motorized moving fader
  - Touch sensitive automation control

The diagram below illustrates the stereo master fader controls in more detail.

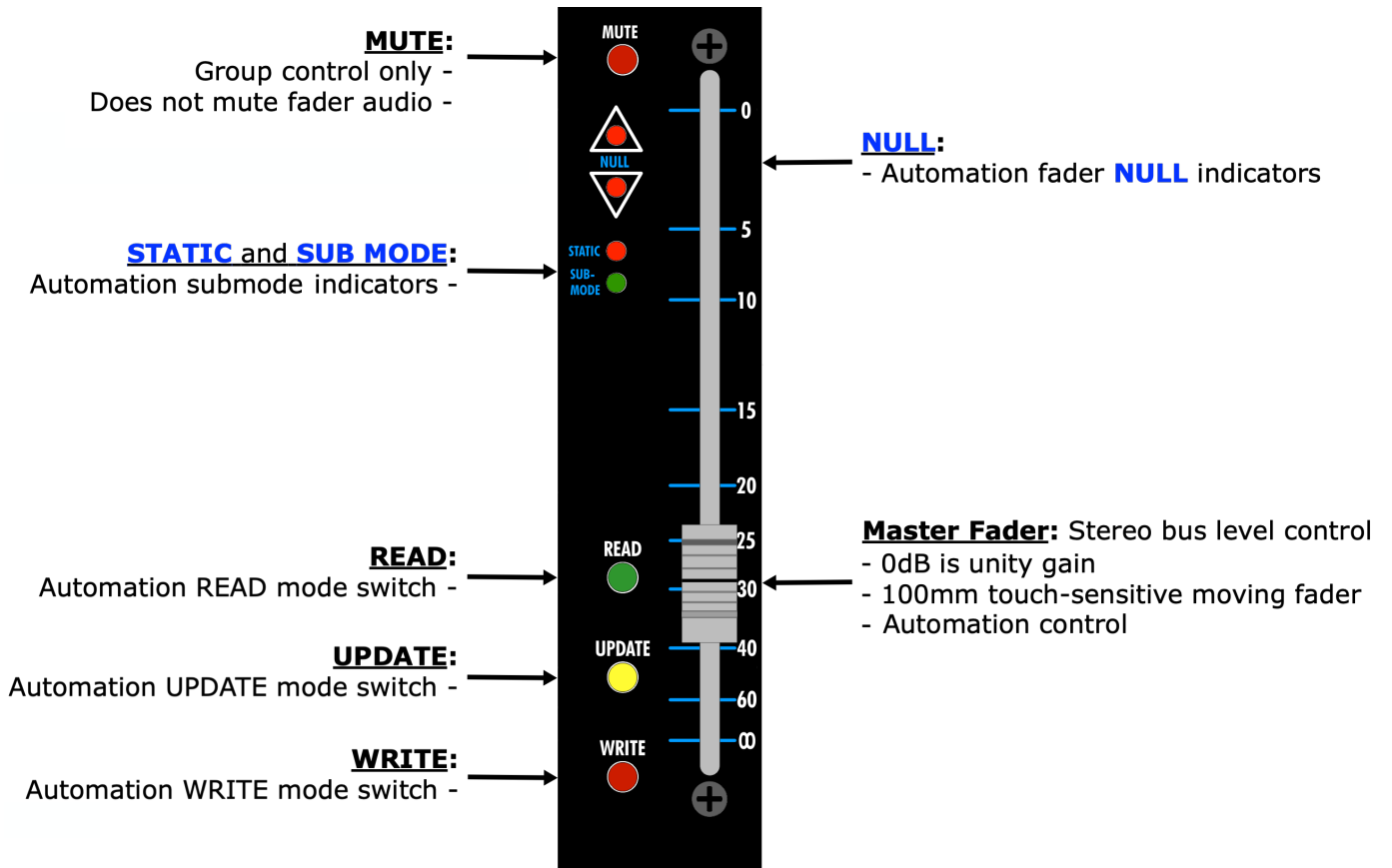

## 6.4 Optional 2500+C Stereo Bus Compressor

Vision+ console can be equipped with an optional API 2500+C Bus Compressor, the console version of the famous API 2500+ stereo bus compressor.

Refer to the 2500+ website for more information:

<https://apiaudio.com/product/2500-stereo-bus-compressor/>

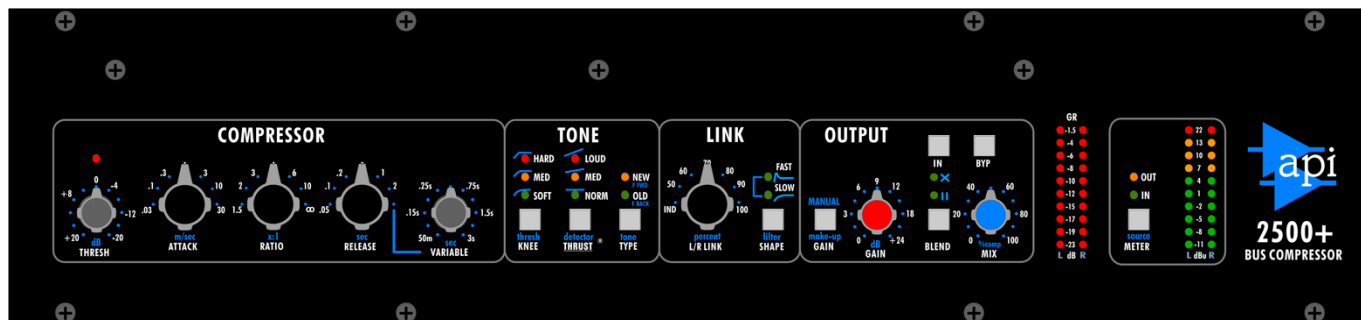

If equipped, the 2500+C is accessible via patch points in the system 2 patch bay.

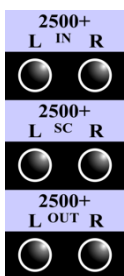

**2500+ IN L-R:** Optional 2500+C stereo bus compressor inputs

- Half-normalled to 2500+ SC L-R

**2500+ SC L-R:** Optional 2500+C stereo bus compressor side chain inputs

- Half-normalled from 2500+ IN L-R

**2500+ OUT L-R:** Optional 2500+C stereo bus compressor outputs

Stereo inputs, side chain, and output patch points are provided. Typical patching for stereo program bus compression using the 2500+C is as follows:

- Patch STEREO ACA OUT L-R to 2500+ IN L-R
- Patch 2500+ OUT L-R to STEREO FADER INPUTS L-R

Apply this patch on the desired stereo program masters **STA**, **STB**, **STC**, or **GM**, as well as any needed side chain patches.

Keep in mind that the 2500+C compressor can be applied to pairs of channels as well for stereo processing during tracking and mixing. This is typically accomplished using the channel inserts and insert patch points.

For complete operating instructions for the 2500+C Bus Compressor, please refer to the 2500+ manual at this link: <https://www.apiaudio.com/docs/manuals/2500+ user 23-01-09.pdf>

## 6.5 Stereo Program Output Modules

Each stereo program bus is integrated with a program output module in the center section. Each side of each stereo program bus, Left and Right, has an **ON**/off switch and output calibration trim pot.

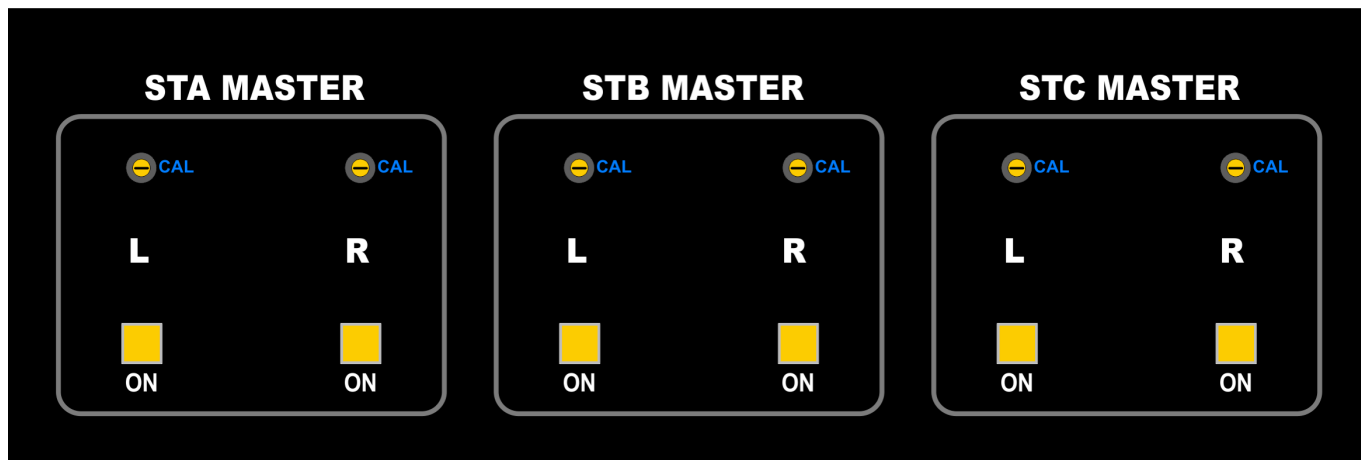

### 6.5.1 Stereo Program Output Controls

Controls for the stereo program output modules are as follows:

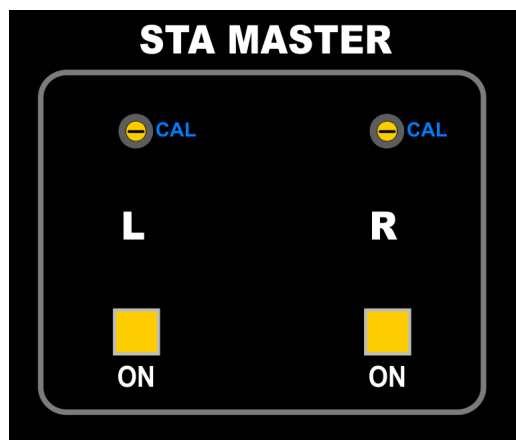

**CAL**: Trim pot for 0dB calibration

**ON (On/off switch)**: Activates the program output

- Illuminates when engaged

The output of the stereo program master output modules feed the BSTR OUT L-R patch points. These patch points are half-normalled to the 2T1 IN thru 2T4 IN patch points.

The output module for stereo grand master is located between the LT RT fold down matrix and the **TALKBACK** controls in the center section.

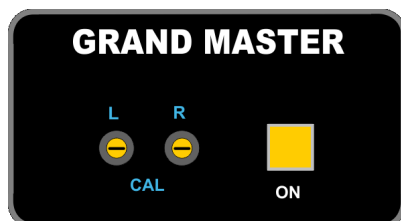

**L-R CAL**: Trim pot for grand master 0dB calibration

**ON (On/off switch)**: Activates the grand master output

- Illuminates when engaged

# 6.6 Stereo Program Patch Points



STEREO/SOLO SUM BUS ACCESS IN L-R: Stereo and solo summing bus access inputs

- Injected into the stereo buses A, B, C, and the solo buses
- Signals patched to these patch points will be added the bus feed before the ACA



STA, STB, STC, & GM Booster Output: Program booster outputs in system bay 3

- Parallel with program booster outputs



STEREO ACA OUTPUTS L-R: Stereo active combining amplifier outputs

- Half-normalled to STEREO FADER INPUTS L-R



STEREO FADER INPUTS L-R: Stereo master fader inputs

- Half-normalled from STEREO ACA OUTPUTS L-R
- Patching to these points will replace the feed to the stereo master faders with the patch cord signals



STEREO BSTR OUTPUTS L-R: Stereo master fader booster outputs

- Fed from **CAL** trim pot in the master stereo program output modules
- Half-normalled to 2T1 thru 2T3 IN L-R



2T1 thru 2T3 IN L-R: Stereo inputs to the 2-track recorder(s) 1 thru 3

- Patching to these points will replace the feed to the 2-track recorder with the patch cord signal
- EDAC connection for studio integration



GM ACA OUT L-R: Stereo grand master active combining amplifier output

- Half-normalled to GM FDR IN L-R



GM FDR IN L-R: Stereo grand master fader inputs

- Half-normalled from GM ACA OUT L-R
- Patching to these points will replace the feed to the grand master fader with the patch cord signal



GM BSTR OUT: Stereo Grand Master Booster output

- Primary Stereo Program Output
- Half-normalled to 2T FEED IN



2T4 IN L-R: Stereo inputs to the 2-track recorder 4

- Patching to these points will replace the feed to the 2-track recorder with the patch cord signal
- EDAC connection for studio integration



EXT GM IN L-R: Stereo external grand master inputs

- Allows an external stereo source to be added to the grand master mix
- Feeds the grand master ACA when the **EXT** switch in the grand master select section is engaged

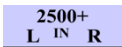

2500+ IN L-R: Optional 2500+C stereo bus compressor inputs

- Half-normalled to 2500+ SC L-R

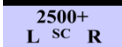

2500+ SC L-R: Optional 2500+C stereo bus compressor side chain inputs

- Half-normalled from 2500+ IN L-R

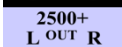

2500+ OUT L-R: Optional 2500+C stereo bus compressor outputs

# 6.7 Stereo Program Signal Flow

The diagram below shows the basic stereo program bus signal flow from the 1068L through the stereo masters and grand master, to the 2-Track inputs.

NOTE: The normals shown in this diagram are all half-normals.

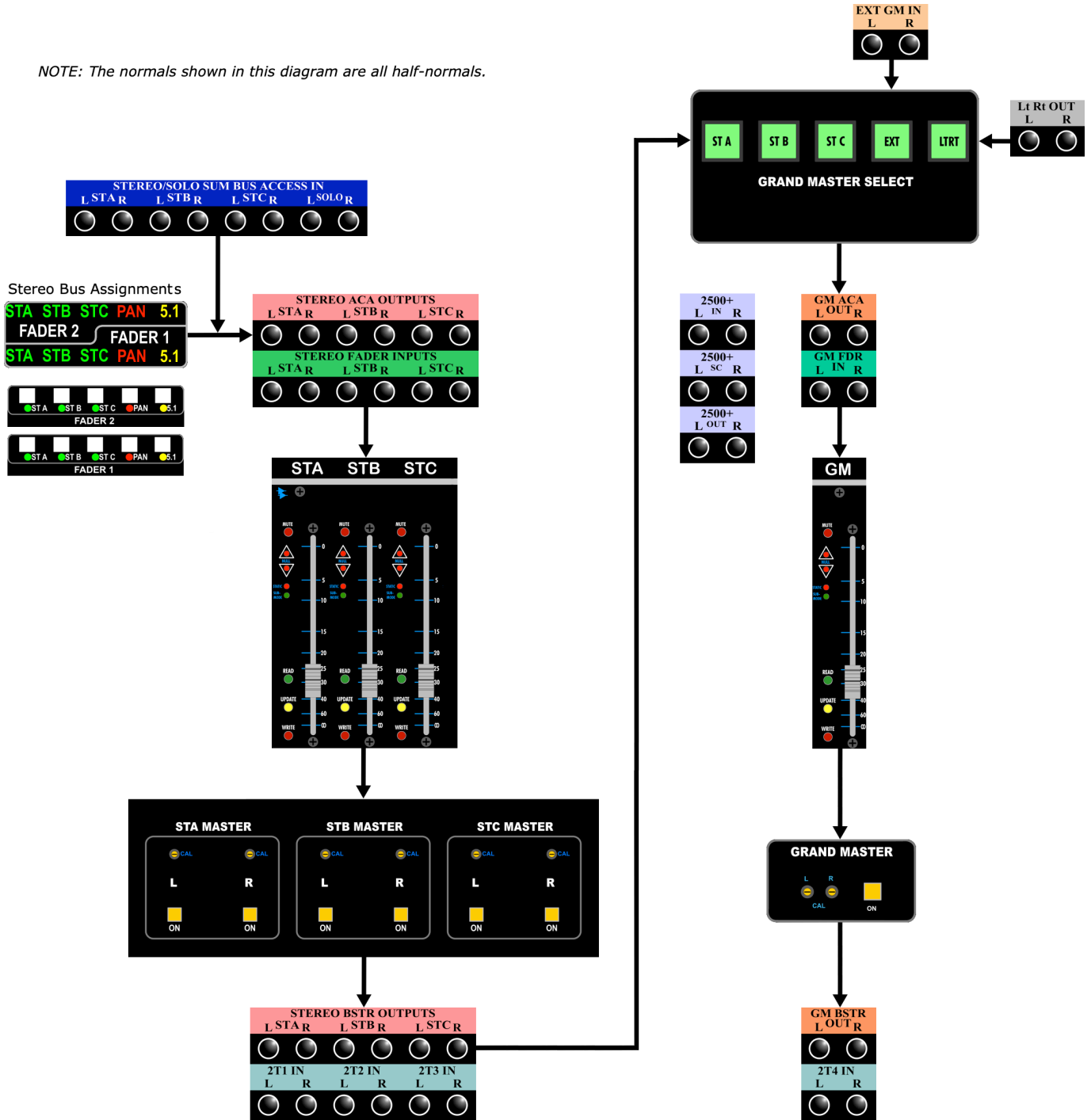

# 7.0 Surround Program Masters

*Vision+* consoles are equipped with 5.1 program masters for surround mixing. Other multichannel surround configurations can be accomplished through the use of auxiliary send and multitrack summing bus outputs. Simultaneous mixing to the surround program masters and all three stereo program masters is also possible. Facilities are provided for real-time fold down of the surround mix to a stereo mix.

*Vision+* consoles are equipped with one (1) set of independent, full-featured, six-channel (5.1), surround program masters:

- **L:** Front Left
- **R:** Front Right
- **Sl:** Surround Left
- **Sr:** Surround Right
- **C:** Center
- **LFE:** Low frequency effect (subwoofer)

It should be noted that the surround program masters are separate and fully independent from the stereo program masters, so unlike other console architectures, the stereo program buses are not needed for surround mixing. So, simultaneous mixing to the surround program masters and all three stereo program buses is possible and not functionally compromised. A real-time fold-down of the surround mix to a stereo Lt Rt mix is also possible. Surround-to-stereo fold-down will be covered later in this chapter.

The structure of the surround program masters include the five (5) surround program buses, their associated active combining amplifiers (ACA), a LFE filter, 5.1 surround output modules, stereo L-R and Sl-Sr (SUR) automated master faders, mono C (center) and LFE automated master faders, an automated 5.1 control group master fader, and a comprehensive set of patch points.

This program bus architecture, combined with a comprehensive set of program bus output modules and patch points provides many routing capabilities including:

- 6-channel 5.1 surround mixing
- Simultaneous surround and stereo mixing
- Surround to stereo fold-down
- Sub-mixing and processing
- Stem mixing
- Mix minus stems (clean channel feed)
- Other applications

## 7.1 5-Channel Surround Program Buses

The *Vision+* consoles are equipped with five (5) independent surround program buses:

- **L**: Front Left
- **C**: Front Center
- **R**: Front Right
- **Sl**: Surround Left
- **Sr**: Surround Right

While the surround program bus assignment is labeled “**5.1**,” assignments are actually made to a 5-channel program bus with five (5) total surround buses and active combining amplifiers (ACAs) as noted above.

*IMPORTANT NOTE: It should be noted that Vision+ consoles are not equipped with a LFE surround program bus. The LFE master is fed via another path such as an auxiliary send or multitrack bus via the patch bay.*

The Fader 1 and Fader 2 outputs of all 1068L channel input modules and the E1068L stereo/surround effects modules can be independently routed to the surround program buses. For the purposes of assigning 1068L modules to the surround program buses, the buses are grouped together using the **5.1** assignment switch in the output assignment module and routing/snapshot control.

The Fader 1 and Fader 2 channel pan-pots and E1068L pan-pots are 5-channel pan-pots:

- **Front**: Left/Right or Left/Center/Right (with the LCR switch engaged)
- **F/R**: Front/Rear panning is provided
- **Rear**: Surround Left/Surround Right

To activate full 5-channel surround panning, the following conditions must be met:

- The channel must be assigned to the surround program bus (5.1)
- The **LCR** pan-pot switch must be engaged

With the **LCR** switch engaged and the pan-pot is panned front and center, the signal will be routed to the center program bus and the feed to the front left and right program buses will be defeated.

If the **LCR** switch is not engaged, the center program bus will not be fed. Signals panned front and center will feed the front left and right surround program buses (-3 dB per side) and will create “phantom center image” between the speakers.

The surround program buses feed their associated active combining amplifiers (ACA).

The outputs of the 5-channel surround ACAs feed the SURROUND ACA OUT patch points. These points are half-normalled to the surround master fader inputs via the SURROUND FADER IN patch points.

Signals from the 5-channel SURR SUM BUS ACCESS INPUT patch points will be added the bus feed from the channels before the surround ACAs.

To complete a 5.1 program output, a low-pass LFE filter is provided to create the low frequency effects surround channel (.1). Because a LFE bus doesn't exist, an LFE feed must be created. To do so patch the output of an auxiliary send or multitrack summing bus master

to one of the LFE FILTER IN patch points. Alternately, engaging the **5 To LFE** switch will feed a sum of the surround program bus booster outputs to the LFE filter input. In either case, the filter must be engaged using the **LFE FLTR** switch and the desired low pass frequency, 80Hz or 120Hz selected. The FILT OUT patch point is half-normalled to the SURROUND FADER IN LFE patch point. From this point forward in the signal flow, the LFE channel is the same signal flow as the other surround program masters.

Boosters calibrate the outputs of the surround program masters. The outputs of the surround master faders feed the surround program output modules (SURROUND BSTR OUT). These modules contain an **ON**/off switch and **CAL** trim pot to calibrate the surround master fader booster for each output. **The SURROUND BSTR OUT patch points are the main 5.1 mix outputs from the console.**

The SURROUND BSTR OUT patch points are half-normalled to the 6 TRACK IN patch points that feed a 6-channel (5.1) surround mix recorder.

The SURROUND BSTR OUT patch points also feed the Lt Rt fold down matrix for creating stereo mixes from surround mixes in real-time. An external surround source may also be added to the fold down mix. The resultant mix available at the Lt Rt OUT patch points and the stereo grand master selectors.

Surround program bus assignments from 1068L input modules may be made:

- Locally on the 16-channel output assignment modules (**5.1** switch)
- Via Routing/Snapshot control

An automated 5.1 control group master fader that groups the surround master faders is provided for easy overall control of the surround mix outputs from a single fader.

# 7.2 Surround Program Master Faders

Vision+ consoles are equipped with one (1) stereo L-R and one (1) stereo SI-Sr (SUR) automated master faders, one (1) mono center master fader, one (1) mono LFE automated master faders, and one (1) automated 5.1 control group master fader. All have automation control.

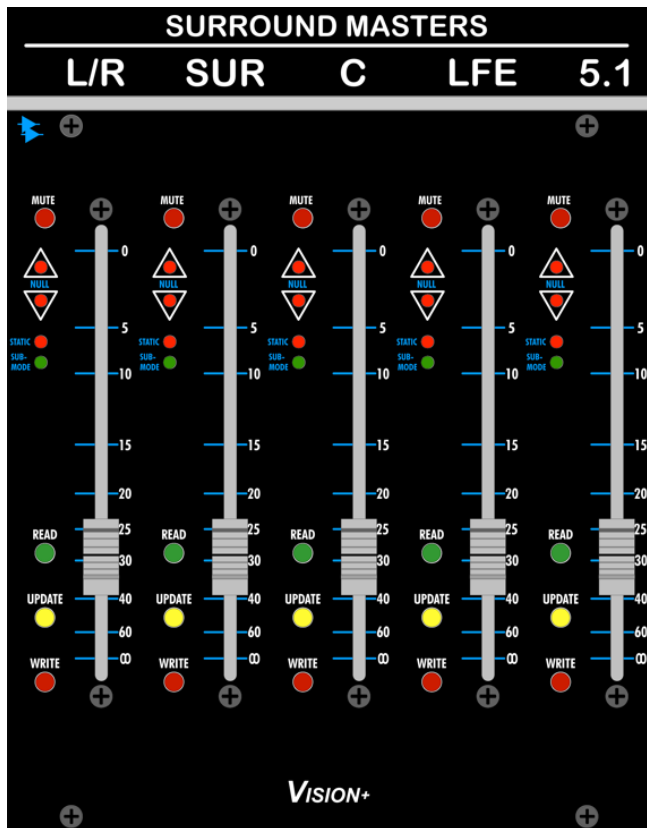

Surround program master faders and sources:

- **L/R**: Front Left-Right ACA OUTPUTS
- **SUR**: Surround Rear SI-Sr ACA OUTPUTS
- **C**: Surround Center ACA OUTPUTS
- **LFE**: Surround Low Frequency effects FILTER OUTPUT

**L/R, SUR, C, LFE**: Stereo and mono surround master faders that are the primary level controls the main surround program outputs

- 0dB is unity gain
- Automation control
  - Full-sized 100mm motorized moving fader
  - Touch sensitive automation control

**5.1**: Surround control group master fader

- Provides 6-channel surround mix output control from a single fader
- Control device only: Does not carry audio
- Automation control
  - Full-sized 100mm motorized moving fader
  - Touch sensitive automation control

The diagram below illustrates the surround master fader controls in more detail.

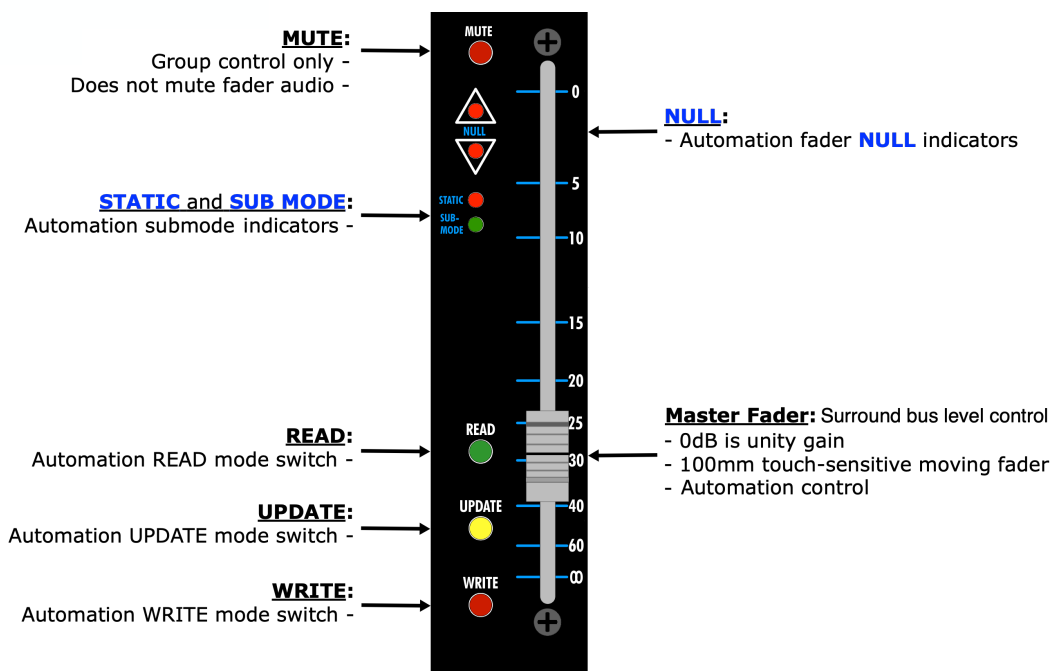

## 7.3 LFE Feed

As mentioned previously, in order to create a complete 5.1 program output, a LFE (low frequency effects or subwoofer) feed must be created. Accordingly, a low-pass LFE filter, LFE surround master fader and LFE surround output module are provided to support the LFE or Low Frequency Effects (subwoofer) channel ... the .1 of a 5.1 mix. However, audio is NOT routed to the LFE filter unless a feed is created and its return is not active unless the filter is engaged. In other words, the surround program outputs will not have a LFE channel unless one is created through proper procedures.

*To be clear, Vision+ consoles are not equipped with a LFE surround program bus or ACA and there is no access to the LFE program outputs from the 1068L channel or E1068L pan-pots.*

Because a LFE surround program bus doesn't exist, an LFE feed must be created using one of the following methods:

- **5 TO LFE:** Feeds a sum of the L, C, R, Sl, and Sr surround program outputs to the LFE filter
- **Auxiliary Send:** Create a LFE on auxiliary sends and patch the auxiliary master output of one of the LFE FILTER IN patch points
- **Multitrack Summing Bus:** Create a LFE using Fader 2 and route it to a multitrack summing bus and patch the bus output to one of the LFE FILTER IN patch points
- **Unfiltered External Source:** Patch the output of an external unfiltered LFE feed to the to one of the LFE FILTER IN patch points
- **Filtered External Source:** Patch the output of an external filtered LFE feed to the SURROUND FADER IN LFE patch point

Use of an auxiliary send is common. If a multitrack summing bus is used, in a typical work flow feed Fader 2 from Fader 1 using the **FDR1** switch so the audio from Fader 1 will be the source of the feed. Then assign Fader 2 to the desired multitrack bus.

When using an auxiliary send or multitrack bus, patch the output of the auxiliary master or multitrack bus master to one of the LFE FILTER IN (1, 2 or 3) patch points (they're wired in parallel). The FILT OUT (filter output) patch point (on the same row as the surround ACAs) is half-normalled to the SURROUND FADER IN LFE patch point.

Use the **LFE FLTR** switch to engage the LFE filter. If this switch is not engaged, unfiltered audio will be routed to the LFE filter outputs.

Use the **120 Hz (80)** switch to select the desired LFE filter frequency, 80Hz (default) or 120Hz.

If using an externally processed source, patch the output of the filtered feed to the SURROUND FADER IN LFE patch point.

From this point forward in the surround mix output, the LFE channel has the same signal flow as the other surround program masters.

## 7.3.1 LFE Filter

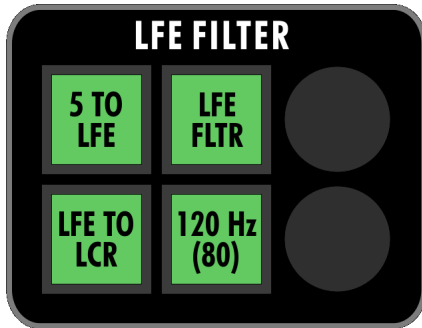

The low-pass **LFE FILTER** is located in the monitor control area of the center section. It is available for use in the surround program bus master system to process a LFE feed for 5.1 surround mix. However it is not automatically engaged in the surround bus structure. Procedures for its use are mentioned briefly above and in detail below.

The controls for the **LFE FILTER** function as follows:



**LFE FLTR** (Low Frequency Effects Filter): Routes the output of the LFE filter to the FILT OUT patch point

- The FILT OUT patch point is half-normalled to the SURROUND FADER IN LFE patch point
- Illuminates when engaged

*NOTE: Unfiltered audio feeding the LFE filter will pass to its output when the **LFE FLTR** switch is not engaged. Engage **LFE FLTR** to hear the properly filtered LFE feed.*

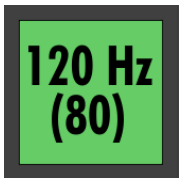

**120 Hz (80)**: Selects the LFE filter frequency

- 80Hz (default) or 120Hz (engaged)
- Illuminates when engaged



**5 TO LFE**: Adds a sum of the L, C, R, Sl, and Sr surround program outputs to the LFE filter

- The summed signal is added to patched LFE inputs before the filter
- Illuminates when engaged



**LFE TO LCR**: Adds the output of the LFE filter to the L, C, R control room monitor outputs

- Illuminates when engaged

### 7.3.1.1 LFE Feed from 5 TO LFE

Engaging the **5 TO LFE** switch will add a sum of the Left, Center, Right, Surround Left and Surround Right surround program outputs to the LFE filter input. This provides a fast means of creating a simple LFE feed based on the 5-channel surround content. The level of the LFE contribution to the surround mix is controlled using the LFE surround master fader.

*NOTE: Be aware that the sum of the Left, Center, Right, Surround Left and Surround Right program outputs is added to the signals from the LFE FILTER IN before the filter circuit when **5 TO LFE** is engaged.*

To create a LFE feed using **5 TO LFE**, use the following procedure:

1. Mute the source feeding the LFE FILTER IN patch points if necessary.
2. Engage the **5 TO LFE** switch.
3. Engage the **LFE FLTR** (LFE filter) switch to activate the LFE filter.
4. Use the **120 Hz (80)** switch to select the LFE frequency: 80Hz (default) or 120Hz
5. Adjust the LFE surround master fader as needed.

The output of the LFE filter is split to feed two patch points, both labeled FILT OUT:



**FILT OUT (Filter Output):** Located with the LFE filter inputs

- Not normalled

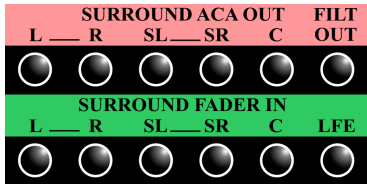

**FILT OUT (Filter Output):** Located with the surround ACA outputs

- Half-normalled to SURROUND FADER IN LFE

From this point forward the LFE signal flow is the same as the other surround masters including the LFE master fader, output module, and patch points.

The diagram below shows the routing for a LFE feed using **5 TO LFE**.

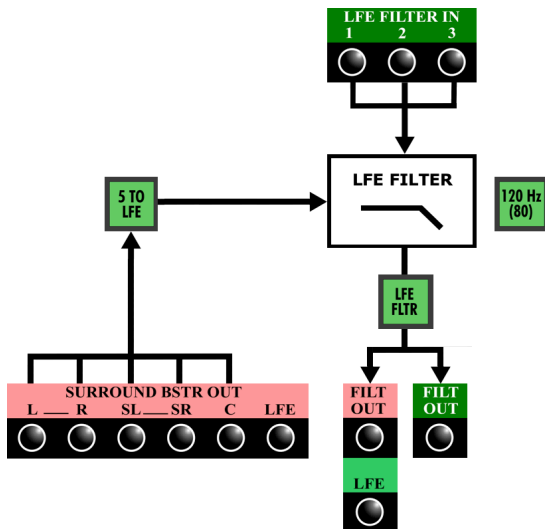

In this scenario, the **5 to LFE** is engaged and a sum of the five channel surround program buses is added to the LFE filter feed. The output of the LFE filter feeds the LFE surround master fader via the FILT OUT to SURROUND FADER IN LFE patch bay half-normal. From here, the normal surround master signal flow is followed including the LFE master fader, output module, and patch points.

The **LFE FILT** switch must be engaged and the desired filter frequency (80Hz or 120Hz) selected using the **120 Hz (80)** switch.

### 7.3.1.2 LFE Feed from a Mono Auxiliary Send

Feeding the LFE from a mono auxiliary send provides a LFE feed that can follow fader moves (post) or operate independently of the fader level (pre). In either case, an individual LFE level control can be provided from each channel.

To create a LFE feed from a mono auxiliary send, use the following procedure:

1. Patch the output of a mono auxiliary send master (227L AUX SEND OUT) to one of the LFE filter inputs (LFE FILTER IN 1, 2, 3) patch points.
2. Make sure the 227L aux send master is turned on and turned up.
3. Engage the **LFE FLTR** (LFE filter) switch in the center section to activate the LFE filter.
4. Select the LFE frequency, 80Hz (default) or 120Hz, using the **120 Hz (80)** switch.
5. Use the aux sends on desired channels to create the LFE feed.
6. Adjust the LFE surround master fader as needed.

The output of the LFE filter is split to feed two patch points, both labeled FILT OUT:

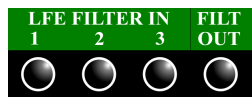

**FILT OUT (Filter Output):** Located with the LFE filter inputs

- Not normalled

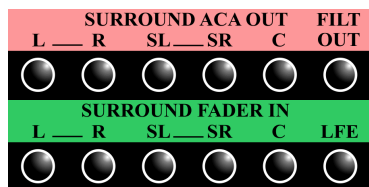

**FILT OUT (Filter Output):** Located with the surround ACA outputs

- Half-normalled to SURROUND FADER IN LFE

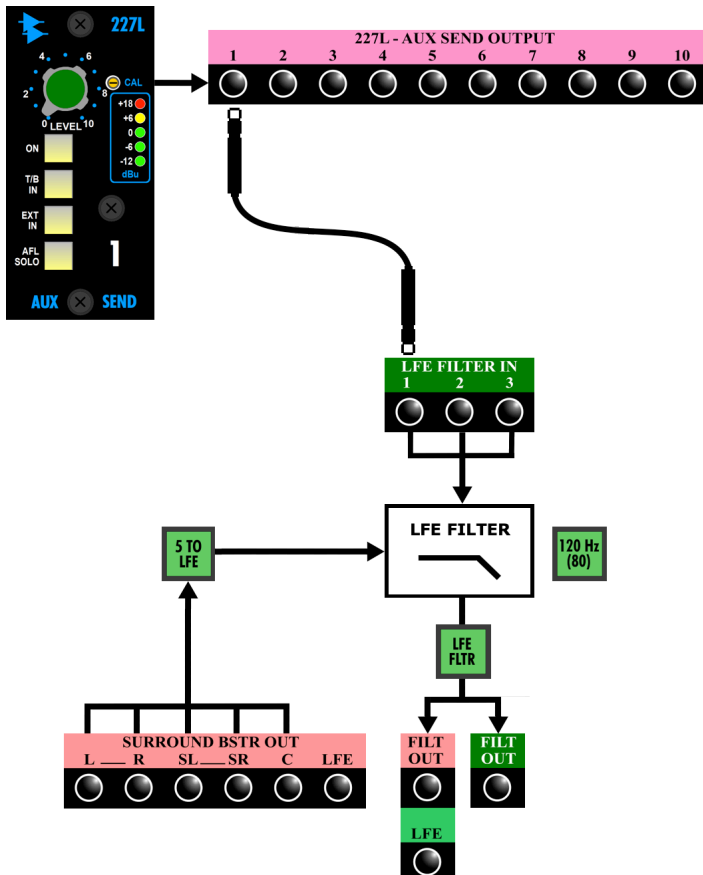

The diagram to the left shows the routing for a LFE feed from mono auxiliary send 1.

In this scenario, mono auxiliary send 1 on desired channels is used to create a mix for an LFE feed the LFE filter. AUX SEND OUTPUT 1 is patched to LFE FILTER IN 1. The output of the LFE filter feeds the LFE surround master fader via the FILT OUT to SURROUND FADER IN LFE patch bay half-normal. From here, the normal surround master signal flow is followed including the LFE master fader, output module, and patch points.

The **LFE FILT** switch must be engaged and the desired filter frequency (80Hz or 120Hz) selected using the **120 Hz (80)** switch.

### 7.3.1.3 LFE Feed from a Multitrack Summing Bus

Feeding the LFE from a multitrack summing bus provides a LFE feed that will follow fader moves (post). If a multitrack summing bus is used, in a typical work flow feed Fader 2 from Fader 1 using the **FDR1** switch so the audio from Fader 1 will be the source of the feed. Then assign Fader 2 to the desired multitrack bus. This will provide an independent LFE feed that will follow the Fader 1 source levels, but can be automated.

To create a LFE feed from a multitrack summing bus, use the following procedure:

1. Patch the output of a multitrack summing bus master (MULTITRACK OUTPUT) to one of the LFE filter inputs (LFE FILTER IN 1, 2, 3) patch points.
2. Make sure the multitrack summing bus master is turned on and turned up
3. Engage the **LFE FLTR** (LFE filter) switch in the center section to activate the LFE filter.
4. Select the LFE frequency, 80Hz (default) or 120Hz, using the **120 Hz (80)** switch.

The output of the LFE filter is split to feed two patch points, both labeled FILT OUT:

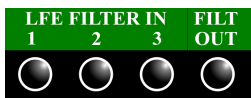

**FILT OUT (Filter Output):** Located with the LFE filter inputs

- Not normalled

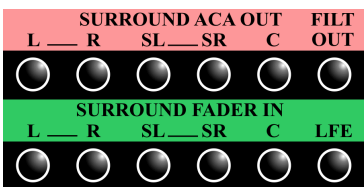

**FILT OUT (Filter Output):** Located with the surround ACA outputs

- Half-normalled to SURROUND FADER IN LFE

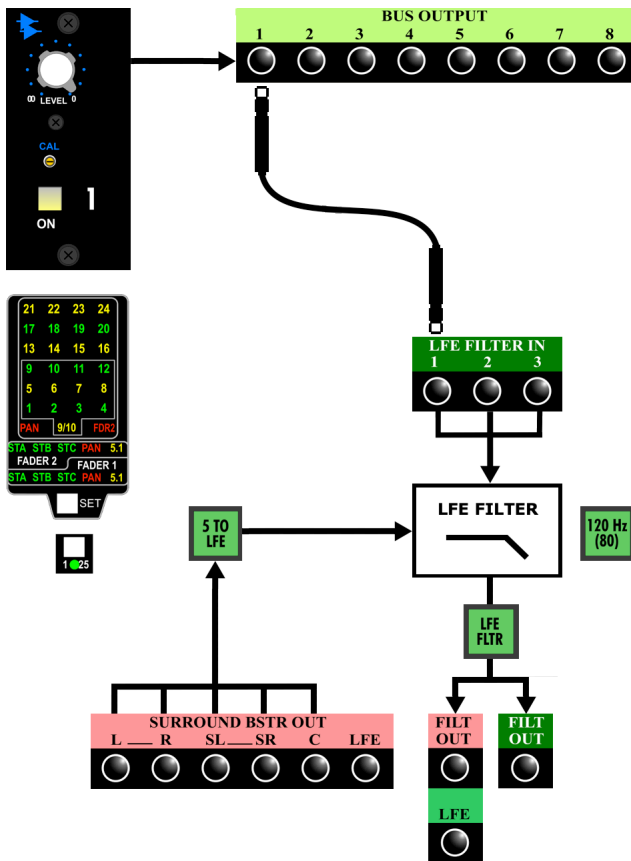

The diagram to the left shows the routing for a LFE feed from multitrack summing bus 1.

In this scenario, Fader 1 is Routed to Fader 2 using the **FDR1** switch. Fader 2 is assigned to multitrack summing bus 1. The output of bus 1 feeds the LFE filter. The output of the LFE filter feeds the LFE surround master fader via the FILT OUT to SURROUND FADER IN LFE patch bay half-normal. From here, the normal surround master signal flow is followed including the LFE master fader, output module, and patch points.

The **LFE FILT** switch must be engaged and the desired filter frequency (80Hz or 120Hz) selected using the **120 Hz (80)** switch.

### 7.3.1.4 LFE Feed from an Unfiltered External Source

The LFE program feed can be created from an unfiltered external source (such as a DAW).

To use an unfiltered external LFE source, use the following procedure:

1. Patch the output of the source to one of the LFE Filter Input (LFE FILT IN) patch points.
2. Engage the **LFE FLTR** (LFE filter) switch in the center section to activate the LFE filter.
3. Select the LFE frequency, 80Hz (default) or 120Hz, using the **120 Hz (80)** switch.

In this scenario, the LFE filter is fed from the unfiltered external source. The output of the LFE filter feeds the LFE surround master fader via the FILT OUT to SURROUND FADER IN LFE patch bay half-normal. From here, the normal surround master signal flow is followed including the LFE master fader, output module, and patch points.

### 7.3.1.5 LFE Feed from a Filtered External Source

The LFE program feed can be created from a properly filtered external source (such as a DAW).

To use a filtered external LFE source, use the following procedure:

1. Patch the output of the source to the LFE surround master fader input (SURROUND FADER IN LFE) patch point

In this scenario, the LFE filter is fed from the filtered external source. The external source feeds the LFE surround master fader via the SURROUND FADER IN LFE patch point. From here, the normal surround master signal flow is followed including the LFE master fader, output module, and patch points.

### 7.3.1.6 LFE Patch Points

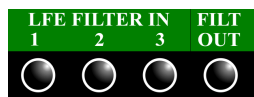

LFE FILT IN 1, 2, 3: Three parallel LFE filter inputs

- Not normalled

FILT OUT (Filter Output): Located with the LFE filter inputs

- Not normalled

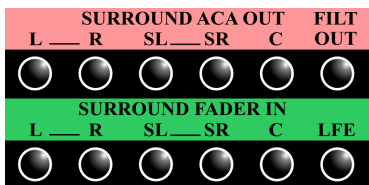

FILT OUT (Filter Output): Located with the surround ACA outputs

- Half-normalled to SURROUND FADER IN LFE

## 7.4 E1068L Surround Effects Return Module

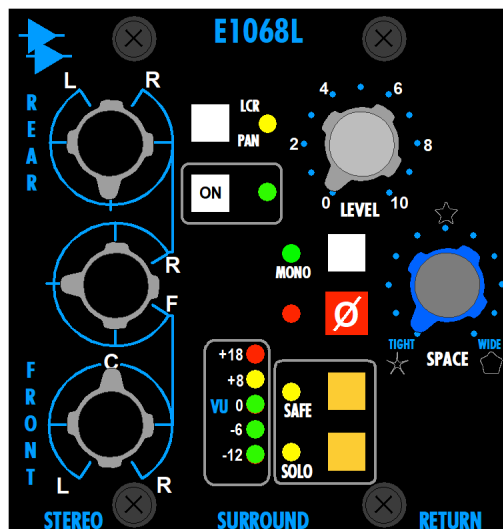

*Vision+* consoles can be equipped with up to six (6) E1068L stereo-to-surround effects returns modules in the options bucket. The E1068L module is a fully featured echo return with surround panning capabilities. It offers a powerful suite of controls that provides the flexibility to handle a wide range of applications.

### Features

- **ON**/off switch
- Output level control
- Surround panning with LRC option
- Panning divergence control (SPACE)
- Mono/stereo input routing
- Phase reverse (polarity inverter)
- Solo with solo safe
- 5-segment LED VU level meter

*NOTE: The E1068L module is two (2) units wide. Each one occupies two (2) 200L options bucket slots and can only be install in the top two rows of the options bucket.*

The stereo L-R outputs of external effects devices (or other sources) are patched to the E1068L SURROUND RETURN INPUT L-R patch points.

*NOTE: The E1068L modules do not feed the stereo program buses. The outputs of external effects devices are patched to channel inputs and routed to the needed stereo program buses when creating stereo mixes.*

### 7.4.1 E1068L Surround Return Controls

The controls on the E1068L Stereo/Surround Return function as follows:



**ON** (ON/off switch): Activates the E1068L module

- A green LED indicator illuminates when engaged



**MONO**: Sums the Left and Right inputs to the E1068L to mono

- A green LED indicator illuminates when engaged



**∅** (Phase Reverse): Inserts a polarity inverter at the E1068L inputs

- A red LED indicator illuminates when engaged

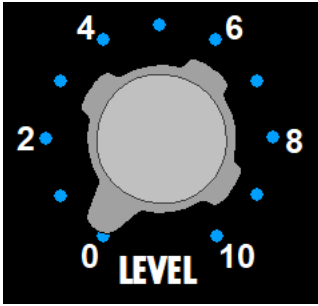

- LEVEL:** Sets the E1068L output level
- Feeds the 5-channel surround program bus

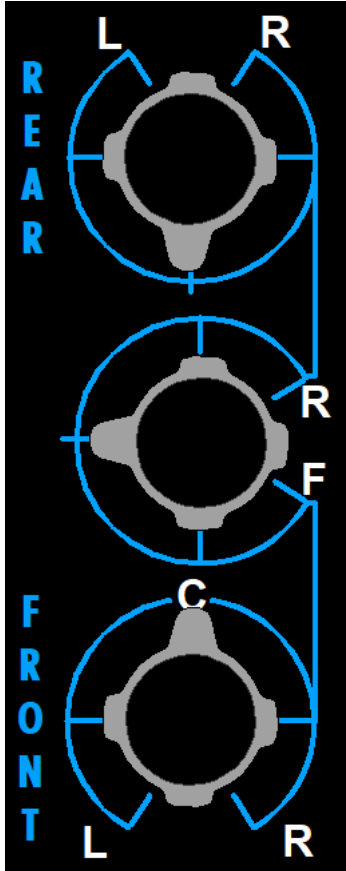

**E1068L Pan-pots**

- REAR (Left-Right):** Rear left-right pan-pot
- Sets the rear left-right pan position to the surround ACAs
  - Center detent

- F/R (Front/Rear):** Front-Rear pan-pot
- Sets the front/rear pan position to the surround ACAs
  - Center detent

- FRONT (Left-Right):** Front left-right pan-pot
- sets the front panning to the front surround ACAs
  - Left-right panning is selected by default for surround panning
  - Front left-center-right panning can be enabled for surround mixing by engaging the **LCR** switch
  - Center detent

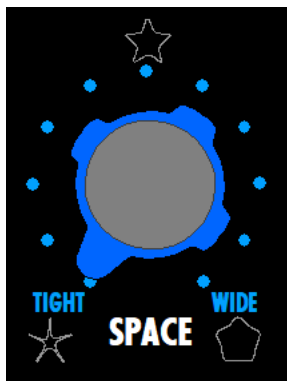

- SPACE:** Sets the amount of divergence in surround pan-pots
- **TIGHT:** Minimum divergence (pan-pot focus is more diffuse or softer)
  - **WIDE:** Maximum divergence (normal panning range)
  - Applied to the **FRONT L-R** and **REAR L-R** pan-pots

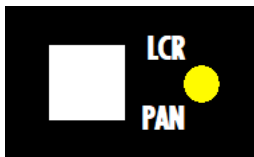

- LCR PAN (Left Center Right):** Activates Left-Center-Right panning
- Left-Right panning is selected by default

- Feeds front/center-panned audio to the center surround buses and removes the signal from the surround left and right buses when engaged
- A yellow LED indicator illuminates when engaged

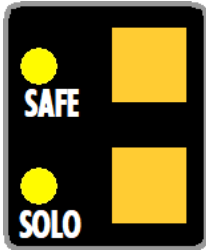

**SAFE:** Activates the solo safe mode

- Inhibits E1068L muting when Solo-In-Place is active and another channel is soloed
- A yellow LED indicator illuminates when engaged

**SOLO:** Activates the selected solo function

- The following solo functions may be selected in the center section:
  - Pre-fader Listen (PFL): Non-destructive, mono, solo bus
  - After Fader Listen (AFL): Non-destructive, stereo, solo bus
  - Solo-In-Place (SIP): Destructive, panned, post-fader, program bus
- A yellow LED indicator illuminates when engaged

*NOTE: AFL is the default solo mode.*

*NOTE: When the **SOLO** switch is engaged the **SOLO CLR** switch in the center section will flash indicating a solo is engaged. HOWEVER, pressing the **SOLO CLR** switch will not clear **SOLO** on the E1068L modules since the E1068L solo switches are hard switches, not soft switches.*



**VU** (meter): Indicates E1068L output level

- 5-segment LED meter

## 7.4.2 E1068L Surround Return Patch Points

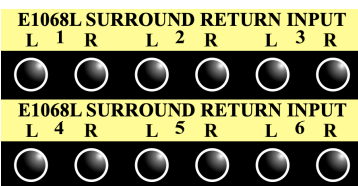

E1068L SURROUND RETURN INPUT 1-6: Inputs to the E1068L modules

- Stereo Left-Right external effects device inputs
- One stereo input per E1068L module

### 7.4.3 E1068L Surround Return Signal Flow

The diagram below shows the routing of the E1068L surround returns for surround mixing applications. Only the first three E1068L modules are shown in this example, but as many as six (6) E1068L modules can be installed and feed the 5-channel surround program bus.

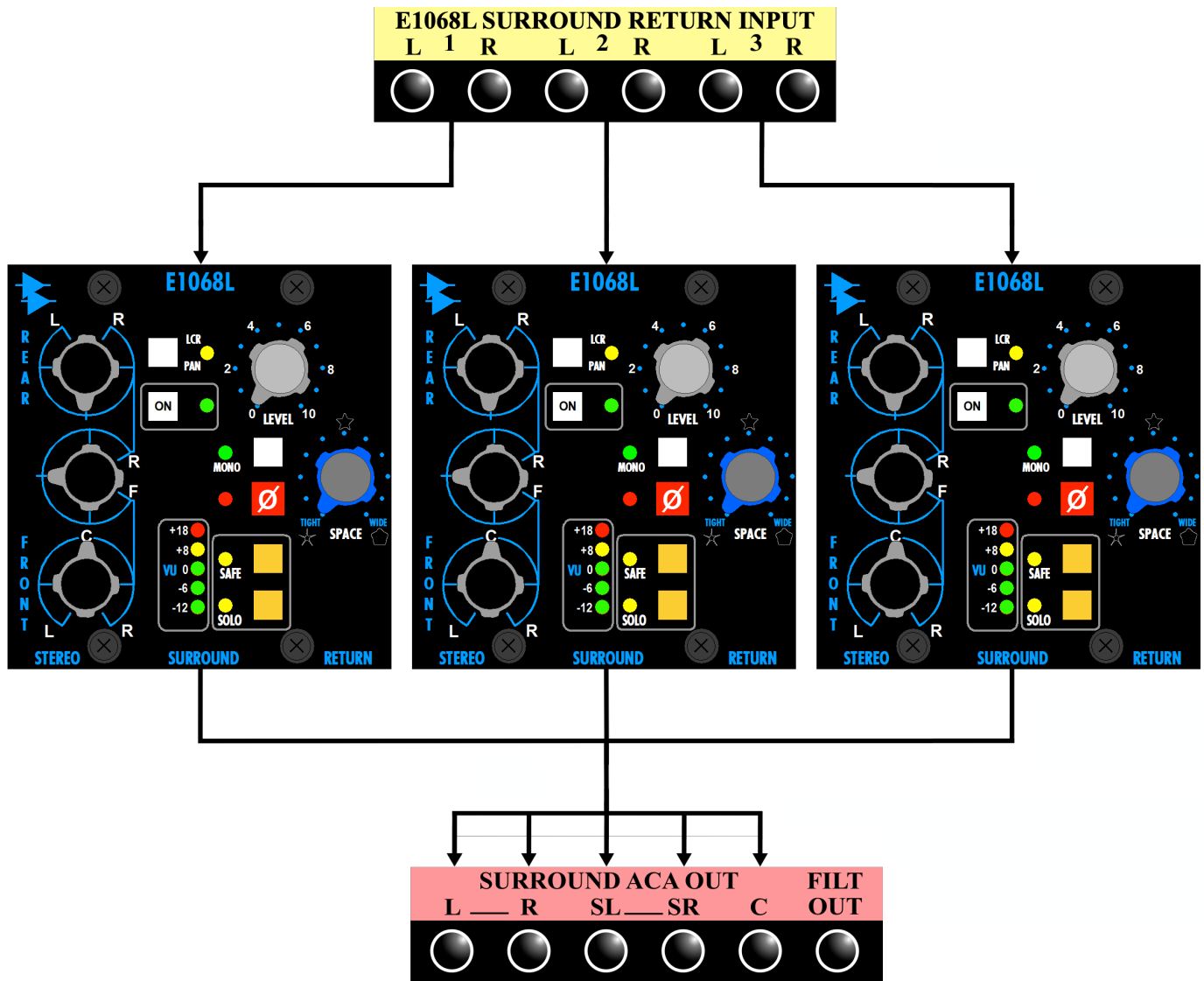

## 7.5 Surround Program Output Modules

Each surround program bus is integrated with a program output module in the center section. Each channel of surround program bus, Left, Right, Surround Left, Surround Right, Center, and LFE has an **ON**/off switch and output calibration trim pot.

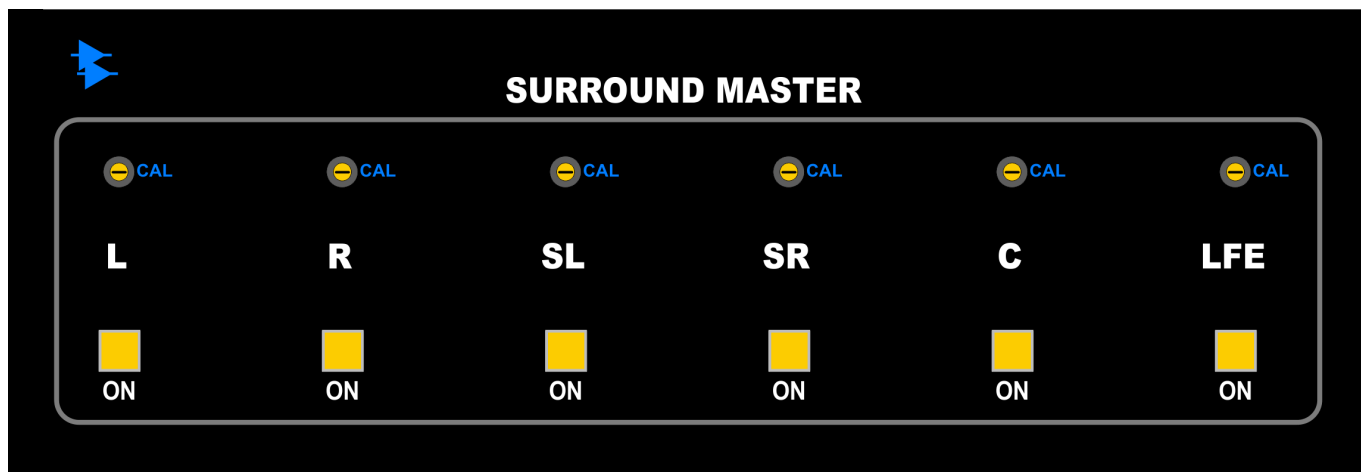

### 7.5.1 Surround Program Output Controls

The controls for the surround program output modules are as follows:

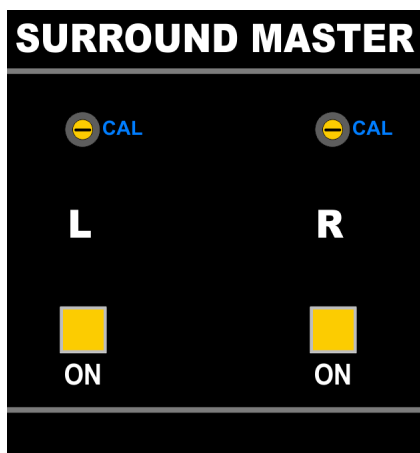

**CAL**: Trim pot for 0dB calibration

**ON** (On/off switch): Activates the program output

- Illuminates when engaged

The output of the surround master output modules feed the SURROUND BSTR OUT patch points. These patch points are half-normalled to the 6 TRACK IN patch points.

# 7.6 Surround Program Patch Points



**SURROUND SUM BUS ACCESS INPUT:** Surround summing bus access inputs

- Normalled to the surround program buses
- Signals patched into the SURROUND SUM BUS ACCESS INPUT patch points will be added to the bus before the surround program ACAs

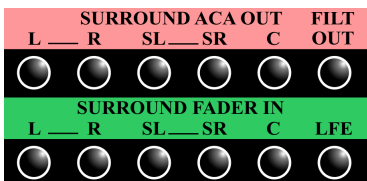

**SURROUND ACA OUT:** Surround active combining amplifier outputs

- Half-normalled to SURROUND FADER IN
- Row includes LFE filter output

**SURROUND FADER IN:** Surround master fader inputs

- Half-normalled from SURROUND ACA OUT
- Patching to these points will replace the feed to the surround master faders with the patch cord signal



**SURROUND BSTR OUTPUTS:** Surround master fader booster outputs

- Fed from **CAL** trim pot in the master surround output modules
- Half-normalled to the 6 TRACK IN patch points

**6 TRACK IN:** Surround inputs to the 6-track recorder

- Patching to these points will replace the feed to the 6-track recorder with the patch cord signal
- EDAC connection for studio integration



**LFE FILTER IN:** Three parallel LFE filter inputs

- Not normalled

**FILT OUT (Filter Output):** Located with the LFE filter inputs

- Not normalled

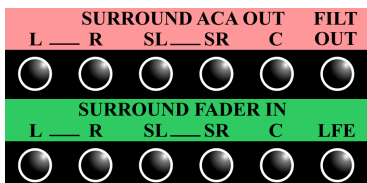

**FILT OUT (Filter Output):** Located with the surround ACA outputs

- Half-normalled to SURROUND FADER IN LFE

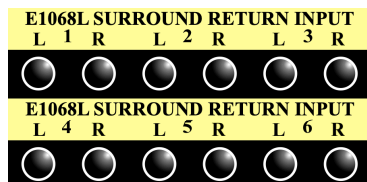

**E1068L SURROUND RETURN INPUT 1-6:** Inputs to the E1068L modules

- Stereo Left-Right external effects device inputs
- One stereo input per E1068L module

# 7.7 Surround Program Signal Flow

The diagram below shows a 5.1 surround program signal flow, including E1068L surround returns, and a LFE feed. A LFE feed may be created by engaging the **5 to LFE** switch or patching the output of a mono auxiliary send or a multitrack summing bus output to one of the LFE FILTER IN patch-points.

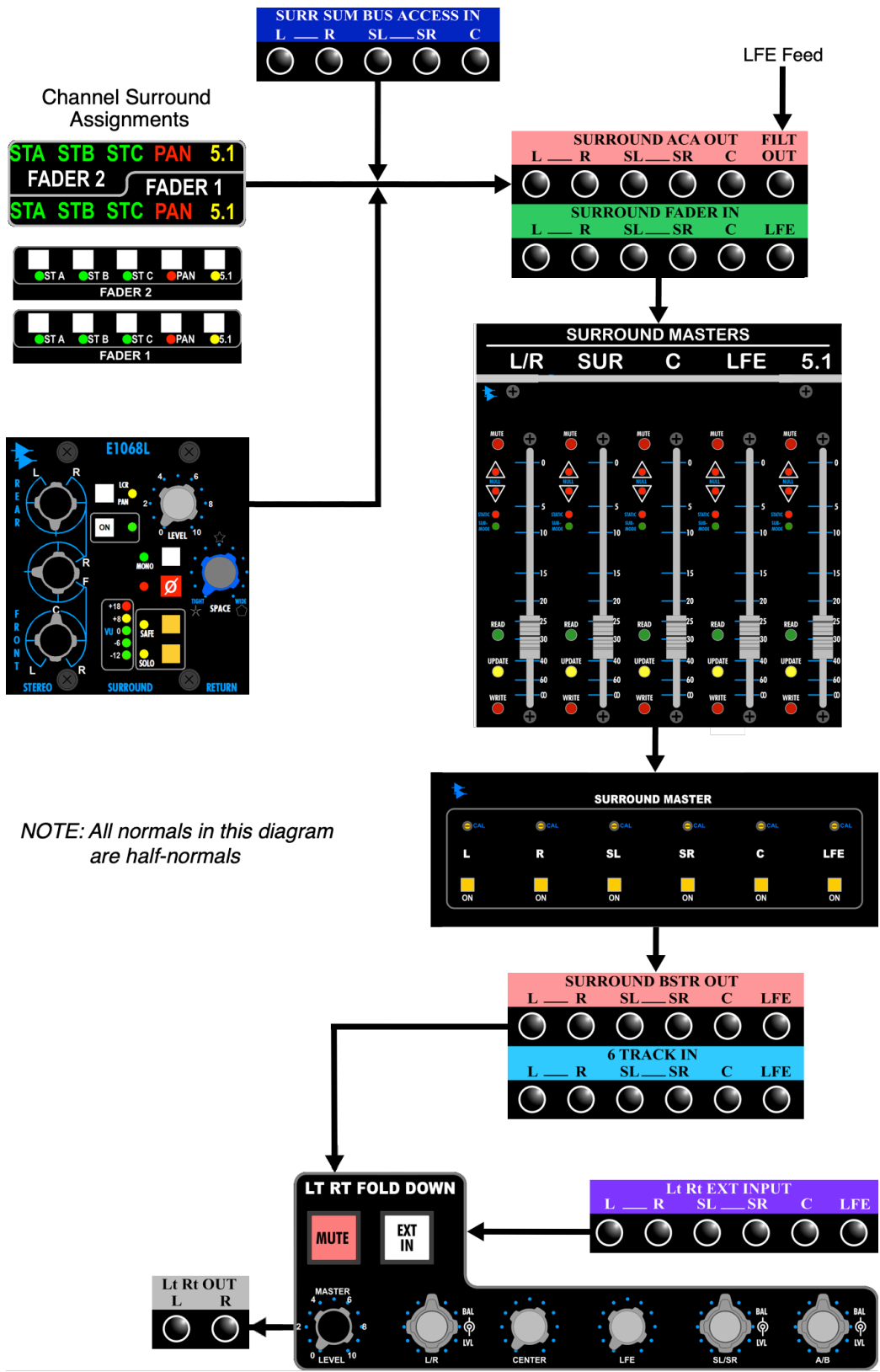

NOTE: All normals in this diagram are half-normals

# 8.0 Surround to Lt Rt Fold Down

Vision+ consoles are equipped with a 7.1 surround to Lt Rt (Left-total – Right-total) stereo fold down matrix. This matrix allows a stereo mix to be created from the surround program outputs while a surround mix is being made.

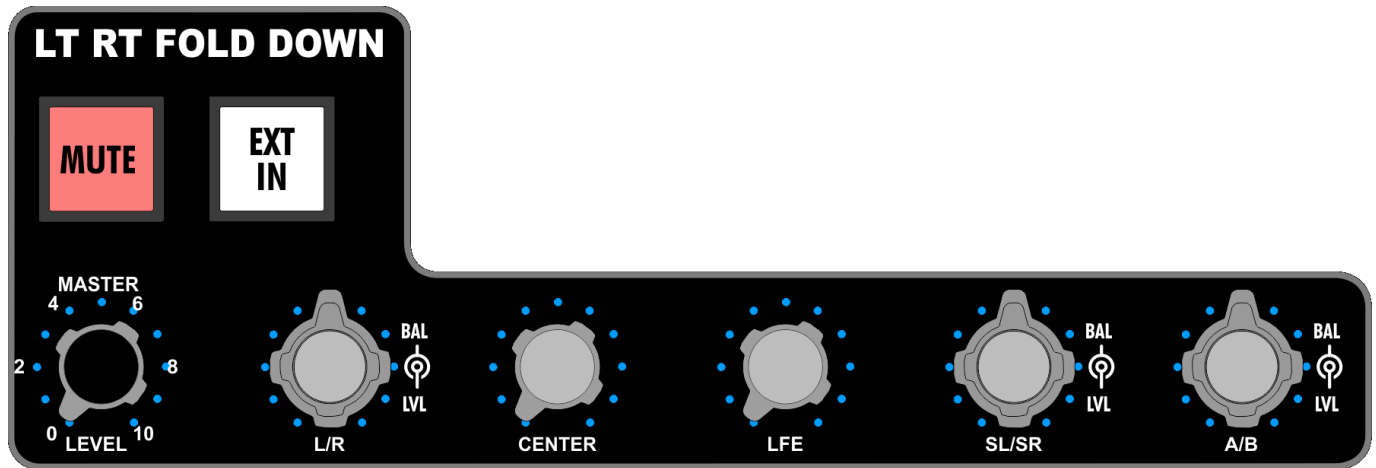

## 8.1 Lt Rt Fold Down Controls

The controls for the Lt Rt fold down function as follows:



**MASTER LEVEL:** Master Left-total and Right-total (Lt Rt) output level control

- Feeds the **LTRT** grand master select switch
- Feeds the Lt Rt OUT patch points

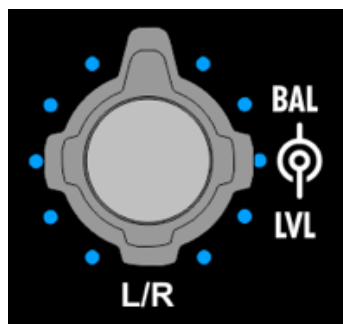

**L/R (Left/Right):** Controls the front Left and Right contribution to the Lt Rt fold down

- **LVL (Level):** Center pot stereo level control
- **BAL (balance):** Ring pot Left/Right balance control



**Center:** Level control for the Center contribution to the Lt Rt fold down

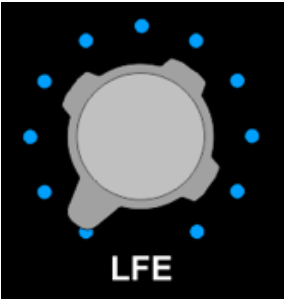

**LFE (Low Frequency Effects):** Level control for the LFE channel contribution to the Lt Rt fold down



**SL/SR (Surround Left/Surround Right):** Controls the rear surround left and surround right contribution to the Lt Rt fold down

- **LVL (Level):** Center pot stereo level control
- **BAL (balance):** Ring pot Left/Right balance control

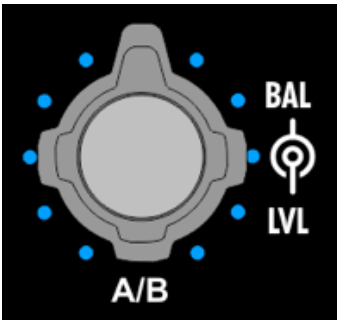

**A/B:** Controls the A and B contribution to the Lt Rt fold down

- **LVL (Level):** Center pot stereo level control
- **BAL (balance):** Ring pot Left/Right balance control



**EXT IN (External Input):** Activates the Lt Rt fold down external input

- Fed from the EXT Lt Rt INPUT patch points
- Illuminates when engaged

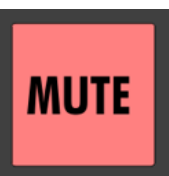

**MUTE:** Cuts the output from the Lt Rt fold down

- Fed from the **MASTER LEVEL** output
- Illuminates in red when engaged
-

## 8.2 Lt Rt Fold Down Patch Points



EXT. Lt Rt INPUT: External surround inputs to the Lt Rt fold down

- Active when the Lt Rt fold down **EXT IN** switch is engaged



Lt Rt OUT (Left-total – Right-total Output): Stereo output of the Lt Rt fold down

- May be routed to the stereo grand master when the grand master select **LTRT** switch is engaged

# 9.0 Auxiliary Send Masters

*Vision+* consoles are equipped with a fully featured auxiliary send system that provides a comprehensive set of options for cue (headphone/foldback) and effects sends.

There are a total of ten (10) auxiliary sends (aux sends), organized as follows:

- Six (6) mono (1-6)
- Two (2) stereo (7/8 and 9/10)
- Organized and routed in pairs (1-2, 3-4, 5-6, and 7/8-9/10)

All ten auxiliary sends may be routed :

- Pre or post fader
- Fader 1 or Fader 2 audio paths

The auxiliary source assignments maybe stored and recalled using the routing and snapshot systems. The channel auxiliary send **ON**/off switches may be automated.

Aux sends 1-6 are primarily used as mono effects sends during recording and mixing, but may be also be used as cue sends during recording if needed. The mono auxiliary sends can also be used to create a LFE feed for surround mixing.

Aux sends 7/8 and 9/10 are intended for use as cue sends (headphone/foldback) during recording and as stereo effects sends during mixing. The following sources may be added to the 7/8 and 9/10 auxiliary buses at the 227M module:

- Grand master output
- Lt Rt fold down output

Aux sends 7/8 and 9/10 share the same routing switches and always have the same source routing (Fader 1 or Fader 2 and pre or post).

Aux Sends 9/10 may be routed to multitrack summing buses 1-8 via the 227M module to provide addition summing outputs.

*NOTE: When aux sends 9/10 are routed to the multitrack summing buses, the feed to auxiliary bus 9/10 from that channel is defeated.*

Talkback may be added to any auxiliary send as needed via the 227L auxiliary out modules.

## 9.1 Auxiliary Send Buses

Whether mono or stereo each individual auxiliary send feeds an individual auxiliary bus, 1-10. The output of these buses is fed to the corresponding 227L module in the center section.

## 9.2 227L Auxiliary Send Output Modules

Each auxiliary send/bus feeds a 227L aux send output module just before its 227 AUX SEND OUTPUT patch points. A 227M cue master module is also included to provide additional routing to the aux send outputs 7/8 and 9/10 for headphone feeds.

The 227L output modules and 227M cue master module are located in the center section.

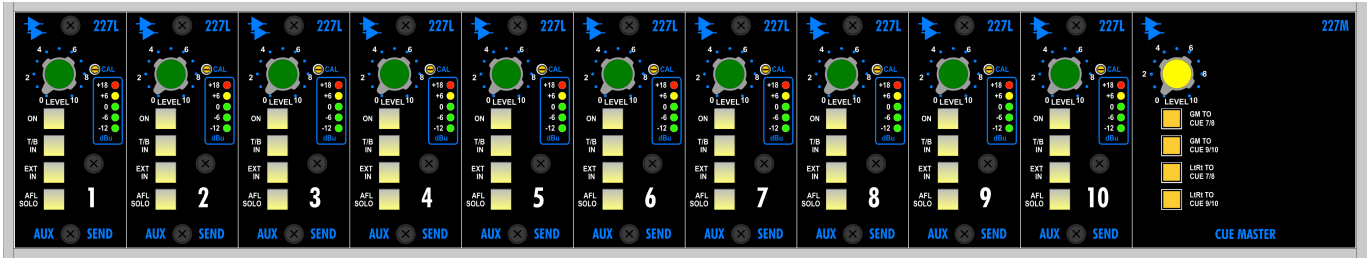

The 227L aux send output module provides master functions for each auxiliary send. A single 227M cue master module provides talkback and cue routing options.

On the 227L module, an external input source may be selected and talkback may be added. **ON/off**, output level, solo controls, output meter, and a calibration trim pot are also included on the 227L module.

The output of the 227L modules feed the 227L SEND OUT patch points, which may be patched to feed studio cue systems, effects devices, or other destinations.

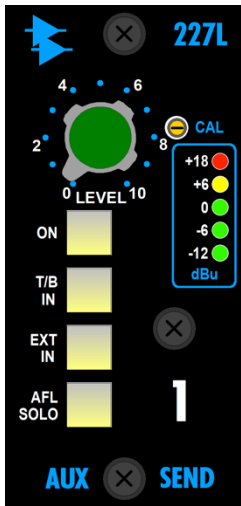

### Features

The 227L aux send output module provides the following features:

- **ON/off** switch
- Output level control
- External input with switch
- Talkback injection
- AFL solo
- 5-segment LED level meter
- Output calibration

## 9.2.1 227L Auxiliary Send Output Module Controls

The 227L controls function as follows:

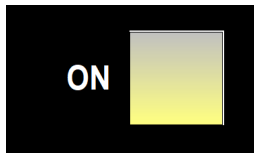

**ON** (On/off switch): Activates the 227L module

- Illuminates when engaged

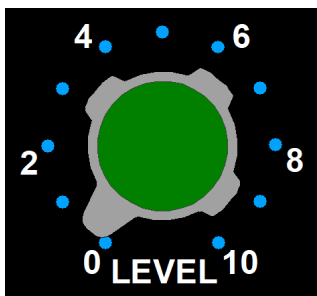

**LEVEL**: 227L output level control

- Feeds the 227L - AUX SEND OUTPUT patch points



- EXT IN** (External Input): Activates the 227L external input
- Adds the signal from the 227L - AUX SEND EXTERNAL INPUT patch point to the aux send when engaged
  - Illuminates when engaged



- T/B IN** (Talkback Input): Routes talkback output to the aux send
- Adds the talkback output to the aux send when engaged
  - Illuminates when engaged

*NOTE: Talkback level is controlled via the TALKBACK controls.*



- AFL SOLO**: Activates the AFL (after fader listen) solo function
- Feeds the stereo solo bus when engaged
  - Non-destructive
  - Illuminates when engaged

*NOTE: AFL solo level is controlled in the center section.*

*NOTE: When the **AFL SOLO** switch is engaged the **SOLO CLR** switch in the center section will flash indicating a solo is engaged. HOWEVER, pressing the **SOLO CLR** switch will not clear AFL SOLO on the 227L modules since the 227L solo switches are hard switches, not soft switches.*

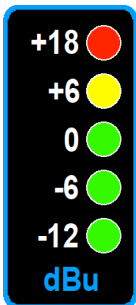

**dBu** (meter): 5-segment LED meter indicates aux send output level



**CAL** (Calibration): Output calibration trim-pot for the aux send

## 9.3 227M Cue Master Module

The two stereo auxiliary sends, 7/8 and 9/10, are designed to be used as cue sends for headphone and foldback feeds while recording and as effects sends while mixing. Accordingly, the 227M cue master module facilitates the routing of the outputs of the grand master and Lt Rt fold down to the stereo auxiliary sends 7/8 and 9/10.

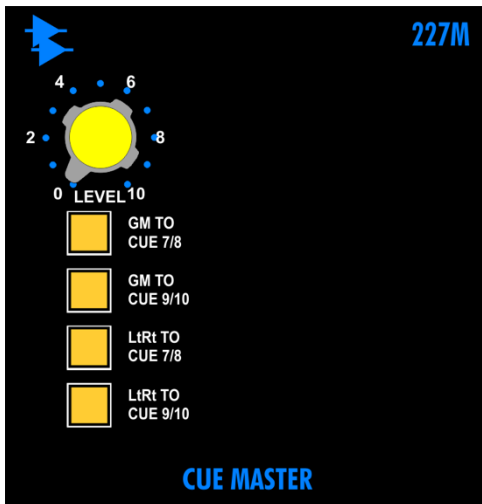

## Features

The 227M cue master module provides the following features:

- Routing of grand master outputs to aux send 7/8
- Routing of grand master outputs to aux send 9/10
- Routing of Lt Rt fold down outputs to aux send 7/8
- Routing of Lt Rt fold down outputs to aux send 9/10
- Level control of selected sources to selected sends

This is used primarily to send the selected program mixes to the headphones while recording. Sends from individual channels may be added to the program mix feeding the aux send output modules. This can be very handy for creating quick cue mixes with ability to reinforce certain tracks as needed.

### 9.3.1 227M Cue Master Controls

The 227M controls function as follows:

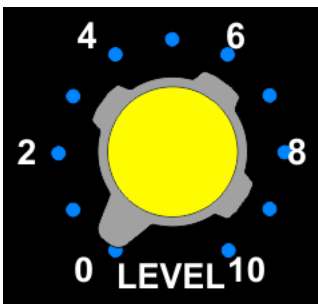

**LEVEL:** Stereo master level control

- Controls the level of the selected GM and/or Lt Rt feeds to the selected aux sends



**GM TO CUE 7/8:** Routes the stereo grand master output to aux buses 7 and 8

- Illuminates when engaged



**GM TO CUE 9/10:** Routes the stereo grand master output to aux buses 9 and 10

- Illuminates when engaged



**LrRt TO CUE 7/8:** Routes the stereo grand master output to aux buses 7 and 8

- Illuminates when engaged



**LrRt TO CUE 9/10:** Routes the stereo grand master output to aux buses 9 and 10

- Illuminates when engaged

# 9.4 Auxiliary Send Patch Points

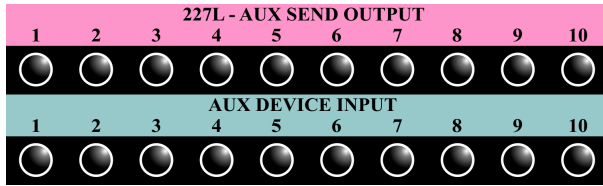

**227L - AUX SEND OUTPUT:** Output of the 227L aux send output modules

- Half-normalled to AUX DEVICE INPUT

**AUX DEVICE INPUT:** Feeds inputs to external effects processors or other destinations

- Half-normalled from 227L AUX SEND OUTPUT
- EDAC connection for studio integration



**227L - AUX SEND EXTERNAL INPUT:** External inputs to the 227L aux send output modules

- Active when the **EXT IN** switch is engaged on the 227L module

# 9.5 Auxiliary Send Signal Flow

The diagram below shows the basic mono auxiliary send 1-6 signal flow.

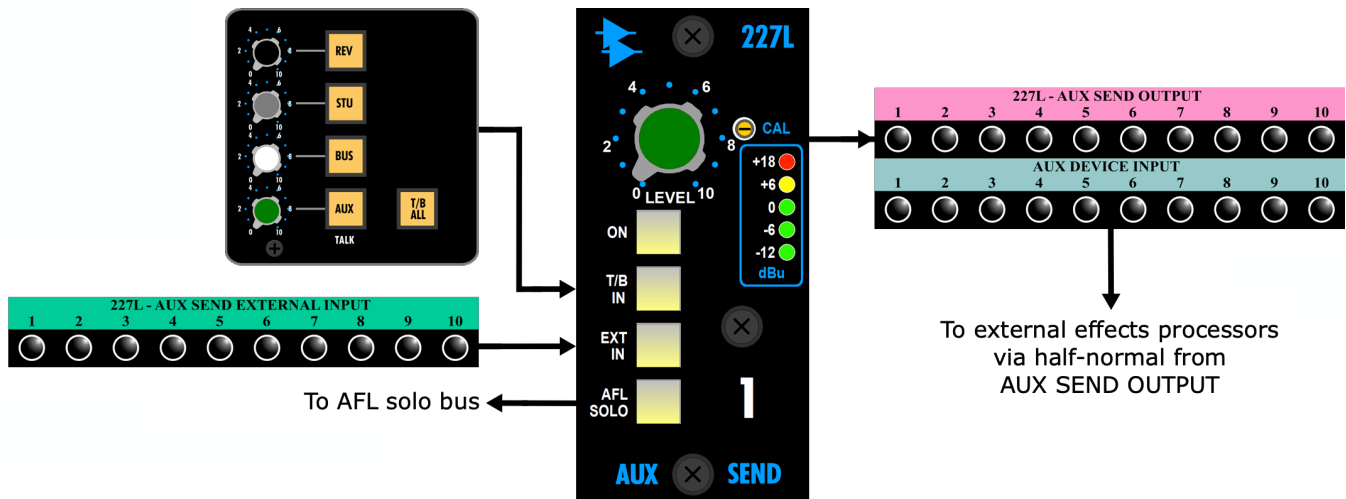

The diagram below shows the basic stereo auxiliary send 7/8 and 9/10 signal flow.

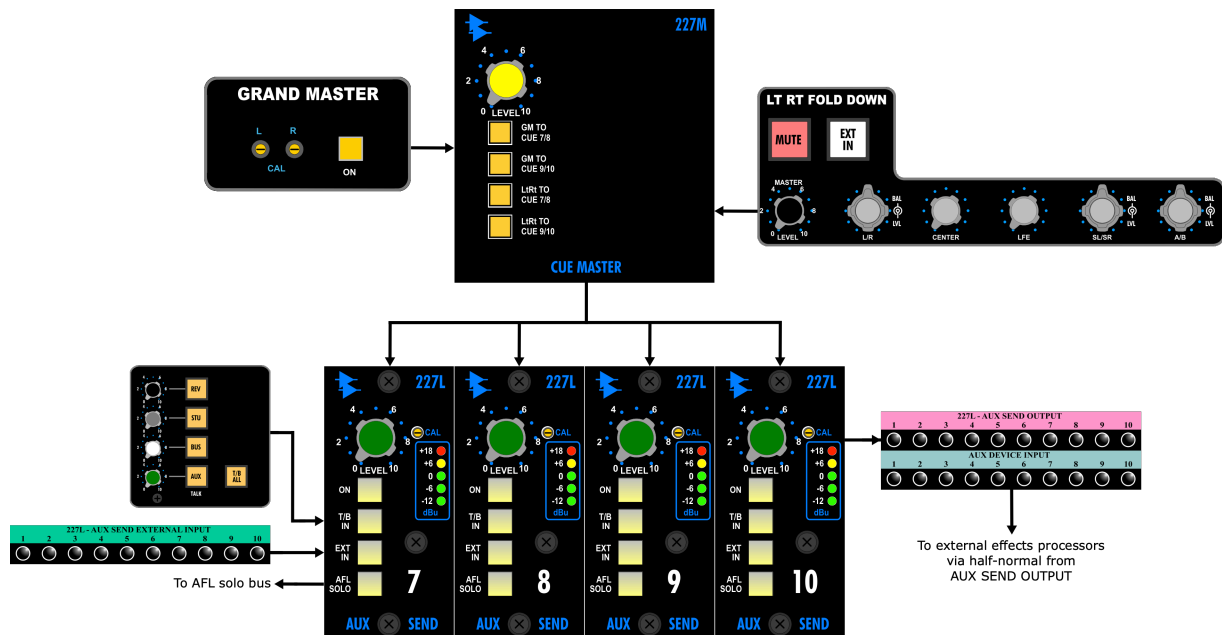

# 10.0 Control Group Master Faders

Vision+ consoles are equipped with six (6) control group masters (GROUP MASTERS) in the center section, located below the options bucket. These Control Group Masters do not pass audio, but are designed to control other faders and mutes on the console.

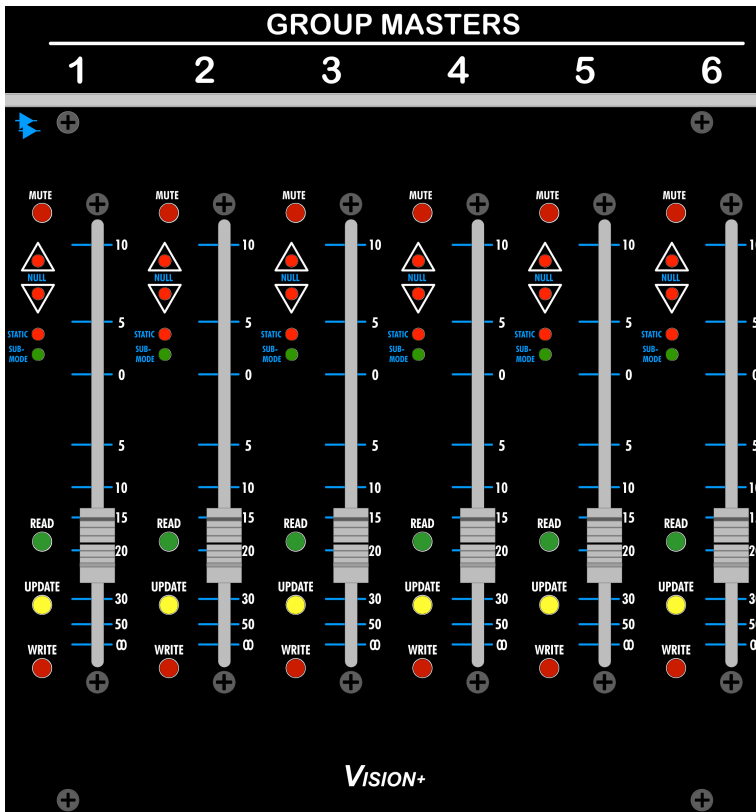

Control groups are created and modified as part of the mix system in the *Final Touch Automation*® and can be controlled from the six control group master faders or channel 1068L modules and their associated faders

## **Group Master 1-6:** Control group master fader and mute

- Provides control group level and mute control from a single fader
- Control device only: Does not carry audio
- Automation control
  - Full-sized 100mm motorized moving fader
  - Touch sensitive automation control

The system can be set to record the moves from just the group master or from the group master and group members.

In addition to the control group master faders, any other fader (any channel fader or program master fader) can be assigned as group master faders. Group masters may be assigned to other group masters to create nested groups.

Control group masters can control the faders and mutes of input channels, as well as the faders of the program masters and other control group masters. Moving the group master fader will cause the group members to follow the group master, moving proportionally according to their position and audio taper. Individual member faders may be adjusted within the group without affecting the other group members.

Control groups that include 1068L switches, as well as faders and mutes can only be controlled by channels because the master must include a 1068L module.

Refer to section 17.0 Groups in the *Final Touch Automation*® manual for more information about control groups and operational details.

[https://www.apiaudio.com/docs/manuals/Final-Touch-Automation\\_user\\_2023-11-01.pdf](https://www.apiaudio.com/docs/manuals/Final-Touch-Automation_user_2023-11-01.pdf)

The diagram below illustrates the group master fader controls in more detail.

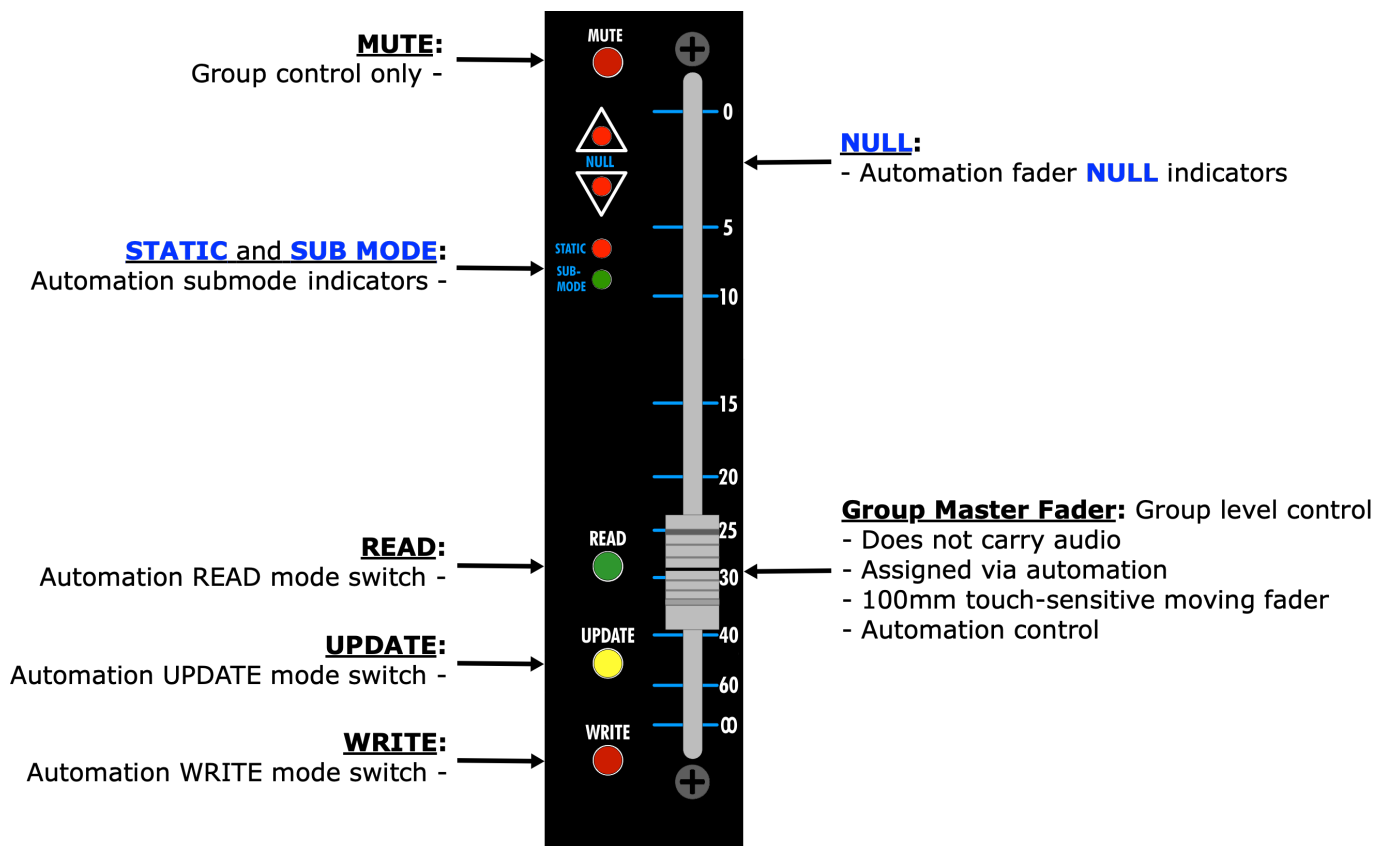

# 11.0 Solo System

*Vision+* consoles are equipped with a fully-featured set of solo functions that employ four different solo modes. The controls in the SOLO area of the center section and a stereo solo bus, combine with the **SOLO** and **SOLO SAFE** switches on channels and console other modules to create a comprehensive solo system designed to meet all production applications.

## 11.1 Solo Modes

*Vision+* consoles provide four (4) solo modes:

- **PFL:** Pre fader listen
- **AFL:** After fader listen
- **SIP:** Solo-in-place
- **MOS:** Mix over solo

### **PFL (Pre Fader Listen):**

- Solo bus is fed pre fader
- Non-destructive
- Control room monitor source is replaced with the solo bus output
- Solo bus level control
- Mono

### **AFL (After Fader Listen):**

- Solo bus is fed post pan-pot (post fader)
- Non-destructive
- Control Room monitor source is replaced with the solo bus output
- Solo bus level control
- Stereo (Left and Right only...no surround, center, or LFE)

### **SIP (Solo-In-Place):**

- Destructive (all other channels/returns will mute when a SOLO switch is engaged)
- Monitored via the assigned program buses
- Post fader
- Panned (stereo or surround)
- Solo-In-Place for Fader 1 and Fader 2 may be assigned individually
- Solo-In-Place for Fader 1 and Fader 2 may operate independently or be linked

### **MOS (Mix Over Solo):**

- Mixes the solo bus output with the selected control room monitor source
- AFL or PFL only (does not work with Solo-In-Place)
- Level pot determines the level of the selected control room monitor source
- **ON/off** switch
- Program bus outputs are common control room monitor source selections for MOS

*NOTE: After Fader Listen (AFL) is the default solo mode (no switches engaged).*

Solo modes and features are selected using the controls in the **SOLO** area of the center section.

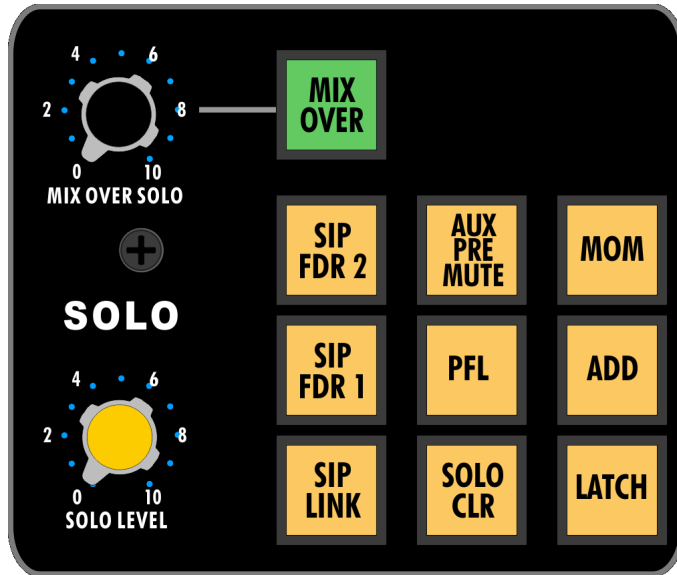

The selected primary solo mode (AFL, PFL, or SIP) is activated when a **SOLO** switch on a 1068L channel module and/or E1068L surround effects return module is engaged.

Engaging the **SOLO** switch on a 227L aux send module will activate the AFL solo mode only.

The 1068L channel **SOLO** switches may be engaged in one of the following solo activation modes:

- **MOM (Momentary)**: Solo function is active only while a **SOLO** switch is held down
  - One or more SOLO switches may be engaged at once
  - Solo function will deactivate when all **SOLO** switches have been released
- **ADD (Additive)**: Multiple **SOLO** switches may be engaged at once
  - Pressed **SOLO** switches will remain engaged when released
  - Individual **SOLO** switches may be disengaged by pressing a them second time
  - Solo function will deactivate when all **SOLO** switches have been released
- **LATCH (Latch)**: Only one **SOLO** switch may be engaged at once
  - A single **SOLO** switch will remain engaged when pressed and released
  - The **SOLO** switch will disengage by pressing a it second time
  - Pressing a second **SOLO** switch while one is already engaged will disengage the active **SOLO** switch and engage the second one

*NOTE: All engaged SOLO switches may be disengaged by pressing the SOLO CLR switch (Solo Clear).*

## 11.2 Solo Controls

The solo controls function as follows:



**SOLO LEVEL:** Sets the level of the solo bus output to the control room monitors

- Sets AFL solo level
- Sets PFL solo level

## SIP FDR 1

**SIP FDR 1 (Solo-In-Place Fader 1):** Activates the Solo-In-Place for Fader 1 solos

- Illuminates in yellow when engaged

## SIP FDR 2

**SIP FDR 2 (Solo-In-Place Fader 2):** Activates the Solo-In-Place for Fader 2 solos

- Illuminates in yellow when engaged

## SIP LINK

**SIP LINK (Solo-In-Place Link):** Links the Fader 1 and Fader 2 Solo-In-Place functions

- Illuminates in yellow when engaged

## AUX PRE MUTE

**AUX PRE MUTE:** Links the 1068L **MUTE** switches with the **ON**/off switch on pre-fader auxiliary sends

- All pre-fader auxiliary sends mute when a channel **MUTE** switch is engaged
- Illuminates in yellow when engaged

## PFL

**PFL (Pre Fader Listen):** Activates the pre fader listen solo of for all solos

- Illuminates in yellow when engaged

## SOLO CLR

**SOLO CLR (Solo Clear):** Disengages any engaged channel **SOLO** switches

- Clears any engaged **SOLO** switches on channel strips
- Momentary (does not stay engaged)
- Flashes in yellow when any **SOLO** switch is engaged on the console (channels, 227Ls, or E1068Ls)

*NOTE: When the **SOLO** switch is engaged on a 227L or E1068L, the **SOLO CLR** switch in the center section will flash indicating a solo is engaged. HOWEVER, pressing the **SOLO CLR** switch will not clear **SOLO** switches on these modules since the 227L and E1068L solo switches are hard switches, not soft switches.*

## MOM

**MOM (Momentary):** Activates the momentary solo mode on channels

- The solo function will be active only while a **SOLO** switch is held down
- One or more SOLO switches may be engaged at once
- Solo function will deactivate when all **SOLO** switches have been released
- Does not apply to 227L or E1068L modules
- Illuminates in yellow when engaged



**ADD (Additive):** Activates the additive solo mode on channels

- Multiple **SOLO** switches may be engaged at once
- Any **SOLO** switches will remain engaged when pressed and released
- Individual **SOLO** switches may be disengaged by pressing a them second time
- Solo function will deactivate when all **SOLO** switches have been released
- Does not apply to 227L or E1068L modules
- Illuminates in yellow when engaged



**LATCH (Latch):** Activates the latch solo mode on channel strips

- Only one **SOLO** switch may be engaged at once
- **SOLO** switches will remain engaged when pressed and released
- The engaged **SOLO** switch will disengage by pressing it a second time
- Pressing a second **SOLO** switch will disengage the active **SOLO** switch and engage the second one
- Solo function will deactivate when all **SOLO** switches have been released
- Does not apply to 227L or E1068L modules
- Illuminates in yellow when engaged

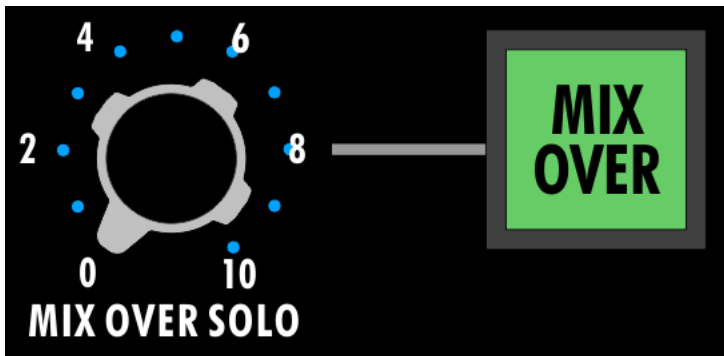

**MIX OVER (Mix Over Solo):** Activates the Mix Over Solo mode for AFL and PFL solos

- Illuminates in green when engaged

**MIX OVER SOLO:** Sets the level of the active control room monitor source when an AFL or PFL solo is activated

- **MIX OVER** switch must be engaged

## 11.3 Solo Bus Access Patch Points



**STEREO/SOLO SUM BUS ACCESS IN L-R:** Stereo and solo summing bus access inputs

- Injected into the stereo buses A, B, C, and the solo buses  
Signals patched to these patch points will be added the bus feed before the ACA

# 12.0 Talkback

Vision+ consoles provides a comprehensive talkback system with flexible routing and options.

Talkback can be routed from three (3) sources:

- **T/B MIC** (Talkback Microphone): A microphone is installed in the center section
  - Routing to cues, studio loudspeakers, and program and multitrack buses
- **EXT T/B MIC** (External Talkback Microphone): An external microphone, typically used for additional control room talkback
  - Routing to cues, studio loudspeakers, and program and multitrack buses
- **REV T/B MIC** (Reverse Talkback Microphone): An external microphone, typically used for studio talkback
  - Routing to control room loudspeakers

## 12.1 Control Room Talkback

The primary control room talkback microphone is mounted next to the TALKBACK section in the center section. Its output feeds an internal preamp and can be routed to the following destinations:

- **AUX** (Auxiliary Sends): All 227L aux send output modules with the T/B switch engaged
- **STU** (Studio): Studio loudspeakers (if engaged)
- **BUS**: Program and multitrack summing buses

An individual momentary activation switch and level control is provided for each destination.

## 12.2 External Talkback

A dedicated input is provided for an external talkback microphone for use as needed. Its output feeds an internal preamp via half-normalled patch points and can be routed to the following destinations:

- **AUX** (Auxiliary Sends): All 227L aux send output modules with the T/B switch engaged
- **STU** (Studio): Studio loudspeakers (if engaged)
- **BUS**: Program and multitrack summing buses

## 12.3 Reverse Talkback

A dedicated input is provided for a studio talkback microphone. Its output feeds an internal preamp via half-normalled patch points and can be routed to the control room monitors.

*NOTE: A reverse talkback microphone is not supplied by API.*

# 12.4 Talkback Mic and Preamp Controls

The **TALKBACK** microphone and preamp controls are located in the center section.

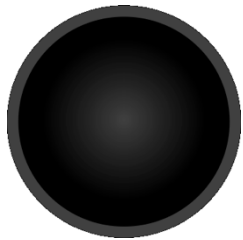
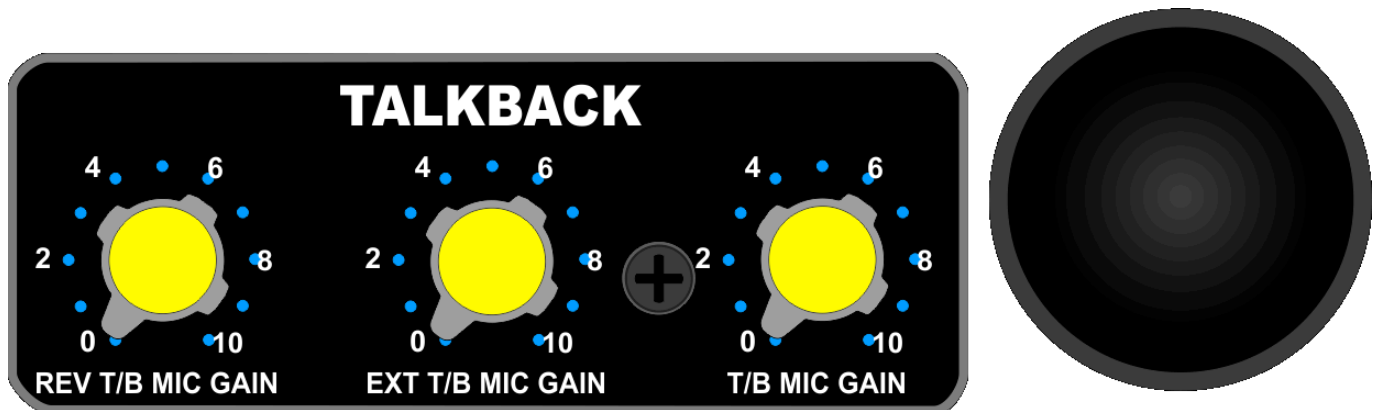

**Talkback Microphone:** Internal high-quality, omni-directional, boundary-layer condenser microphone

- Located next to the talkback preamp controls in the center section

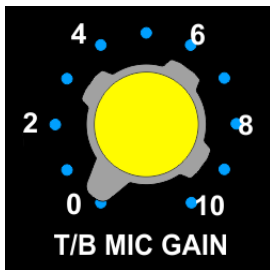

**T/B MIC GAIN (Talkback Microphone Gain):** Internal talkback microphone preamplifier level control

- Internal talkback microphone preamp output is routed to the selected destination(s) via talkback routing controls in the center section

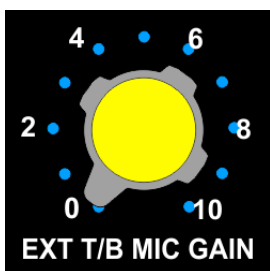

**EXT T/B MIC GAIN (External Talkback Microphone Gain):** External talkback microphone preamplifier level control

- External talkback microphone preamp output is routed to the selected destination(s) via talkback routing controls in the center section
- Fed from T/B PRE IN EXT IN patch point



**REV T/B GAIN (Reverse Talkback Gain):** Reverse talkback microphone preamplifier level control

- Reverse talkback microphone preamp output is routed to the control room monitors via the talkback routing controls in the center section
- Fed from T/B PRE IN PRE IN patch point

## 12.5 Talkback Routing Controls

Talkback routing activators and level controls are located in the monitor control area in the center section.

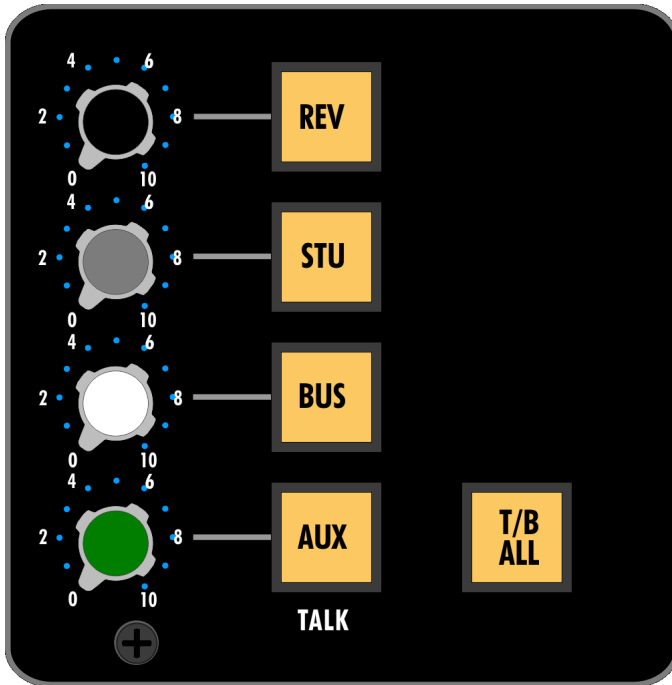

**REV** (Reverse Talkback): Activates reverse talkback

- Level control
- Switch illuminates when pressed/engaged

**STU** (Studio): Activates talkback to studio loudspeakers\*

- Level control
- Switch illuminates when pressed/engaged

**BUS**: Activates talkback to all program and multitrack summing buses

- Level control
- Switch illuminates when pressed/engaged

**AUX**: Activates talkback to all 227L aux send module with **T/B IN** switch engaged

- Level control
- Switch illuminates when pressed/engaged

**T/B ALL**: Activates talkback to all destinations

- Momentary switch illuminates when engaged

\* Talkback to the studio monitors is disabled when the STU CUT is engaged.

*NOTE: The control room monitors will DIM when any TALK switch is engaged.*

The **REV**, **STU**, **BUS**, and **AUX** switches have dual-functionality as follows:

- **Momentary Function**: Long-press (press and hold)
  - Engaged while switch is held down
  - Disengages when released
- **Latching Function**: Press and quick release
  - Remains engaged after quick release
  - Disengages after long-press (press and hold)

*NOTE: The **T/B ALL** switch is always momentary.*

## 12.6 Assigning Talkback to Auxiliary Send

Talkback to CUE (Auxiliary Sends) is assigned to individual Auxiliary Sends on the 227L Cue Send module.

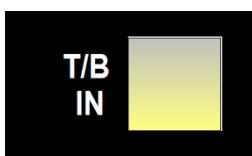

**T/B IN** (Talkback Input): Routes talkback output to the aux send

- Adds the talkback output to the 227L aux send module when engaged
- Illuminates when engaged

# 12.7 Talkback Patch Points

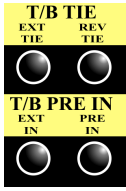

T/B TIE: Tie lines for the external and reverse talkback microphones

- Full-normalled to the T/B PRE IN patch points
- EDAC connection for studio integration

T/B PRE IN: Input to the external and reverse talkback microphone preamplifiers

- Full-normalled from the T/B TIE patch points

# 13.0 Control Room Monitor Control

Vision+ consoles provide comprehensive control room monitor control facilities.

Features include:

- Support for up to three (3) complete stereo/surround control room monitor systems
- Independent level control of each set of alternate control room monitors
- Stereo and surround program monitoring
  - Five (5) stereo program sources
  - One (1) 5.1 surround program source
- Stereo and surround playback monitoring
  - Six (6) external stereo playback sources
  - Two (2) 5.1 external surround playback sources
- Subwoofer support for stereo monitoring
- Individual control room monitor solo and cut functions
- Dim function with level
- Mono, flip, and all cut controls
- Monitor output calibration and test points

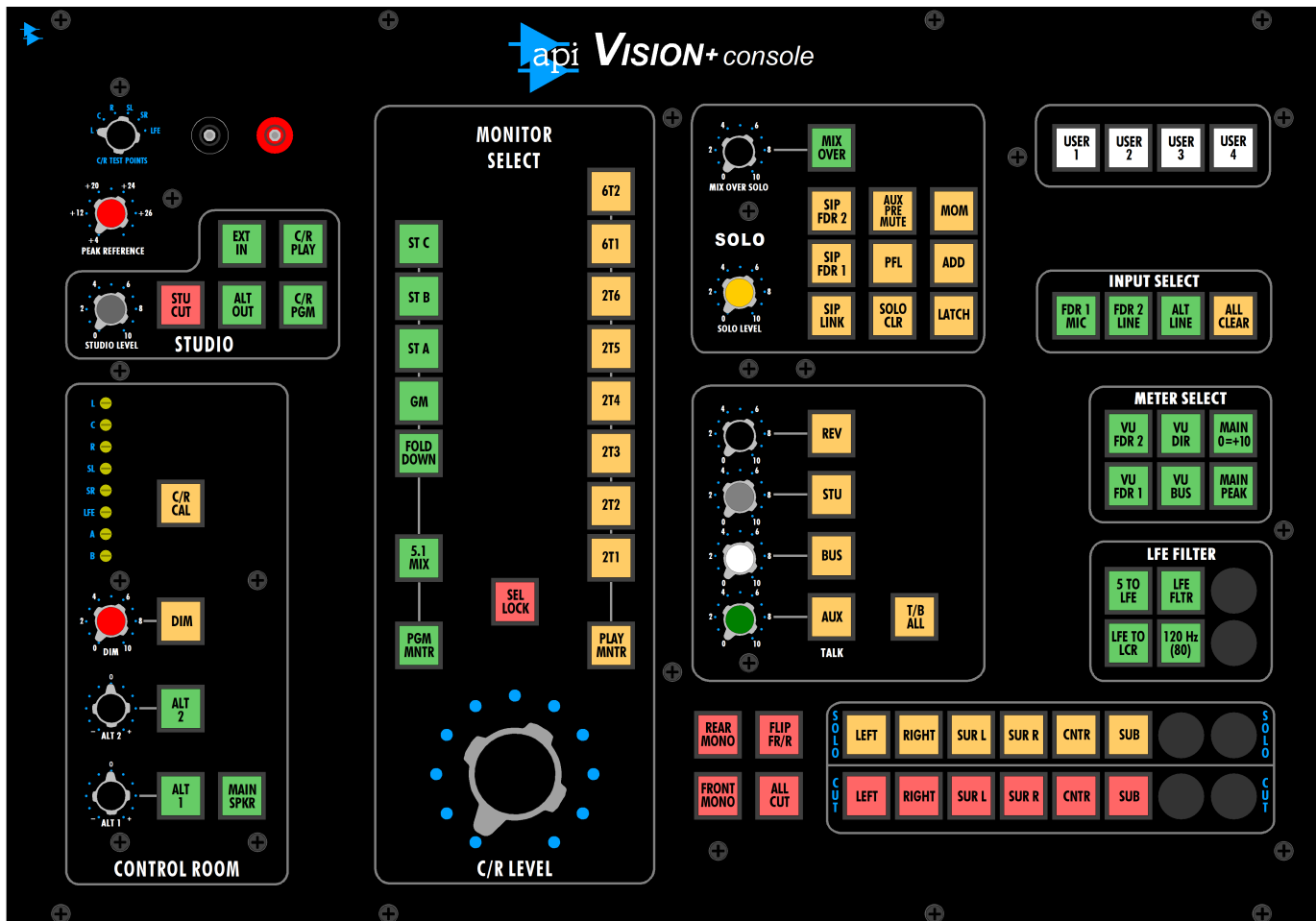

# 13.1 Control Room Stereo Monitoring

Support is provided for three (3) complete stereo/5.1 surround control room monitoring systems, MAIN, ALT 1 and ALT 2. The left and right speakers for the active system are used for stereo monitoring.

The subwoofer can be enabled for monitoring stereo sources. This will feed the subwoofer an unfiltered sum of the stereo left and right monitor outputs. Like all monitor outputs, the subwoofer feed can be independently cut.

The source for stereo monitoring may be selected from eleven (11) total sources, five (5) internal program feeds or six (6) external playback feeds. The following sources may be monitored in stereo:

## Program Sources:

- Stereo A (**ST A**)
- Stereo B (**ST B**)
- Stereo C (**ST C**)
- Stereo grand master (**GM**)
- Lt Rt surround fold down (**FOLD DOWN**)

## Playback Sources:

- Two-track 1 (**2T 1**)
- Two-track 2 (**2T 2**)
- Two-track 3 (**2T 3**)
- Two-track 4 (**2T 4**)
- Two-track 5 (**2T 5**)
- Two-track 6 (**2T 6**)

The following functions may be applied:

- Control room monitor system selection (main, Alt 1, or Alt 2)
- Control room monitor level controls
- All cut
- Dim function with level
- Subwoofer feed with cut
- Individual monitor solo and mute for both speaker feeds
- Mono summing
- Source selection lock

# 13.2 Control Room Surround Monitoring

Support is provided for three (3) complete stereo/5.1 surround control room monitoring systems, MAIN, ALT 1 and ALT 2.

The source for the surround monitors may be selected from three (3) total sources, one (1) internal program feed or two (2) external playback feeds. The following sources may be monitored in surround:

## Program Source:

- Surround program (**5.1 MIX**)

**Playback Sources:**

- Six-track 1 playback (**6T 1**)
- Six-track 2 playback (**6T 2**)

The following features may be applied:

- Speaker system selection
- Control room level controls
- All Cut
- Dim function with level
- Individual monitor solo and mute for all speaker feeds (Left, Center, Right, Surround Left, Surround Right, Sub)
- Front mono summing
- Rear mono summing
- Front to rear speaker flip
- Source selection lock
- Main and alternate studio monitor feeds
- Studio monitor levels

# 13.3 Control Room Monitor Source Selection

The control room **MONITOR SELECT** section allows the choice of stereo and surround program and playback monitor sources and contains the main control room monitor level control.



Internal and external monitor sources may be selected:

- Internal: Program master and fold down
- External: Playback returns from external record/playback devices

The following internal program masters may be selected as the control room monitor source:

- **ST A**: Output of stereo A program master
- **ST B**: Output of stereo B program master
- **ST C**: Output of stereo C program master
- **GM**: Output of stereo program grand master
- **FOLD DOWN**: Output from Lt Rt fold down
- **5.1 MIX**: Output of the surround program masters

The following external playback returns may be selected as the control room monitor source:

- **2T1 (2-track 1)**: Stereo return from 2-track recorder-playback device #1
- **2T2 (2-track 2)**: Stereo return from 2-track recorder-playback device #2
- **2T3 (2-track 3)**: Stereo return from 2-track recorder-playback device #3
- **2T4 (2-track 4)**: Stereo return from 2-track recorder-playback device #4
- **2T5 (2-track 5)**: Stereo return from 2-track recorder-playback device #5
- **2T6 (2-track 6)**: Stereo return from 2-track recorder-playback device #6
- **6T1 (6-track 1)**: Surround return from 6-Track recorder-playback device #1
- **6T2 (6-track 2)**: Surround return from 6-Track recorder-playback device #2

## 13.3.1 Control Room Source Selectors and Level Control

To select one of the program masters as the control room monitor source, the **PGM MNTR** (Program Monitor) switch must be engaged. The selected program master source will be routed to the control room monitor feed.

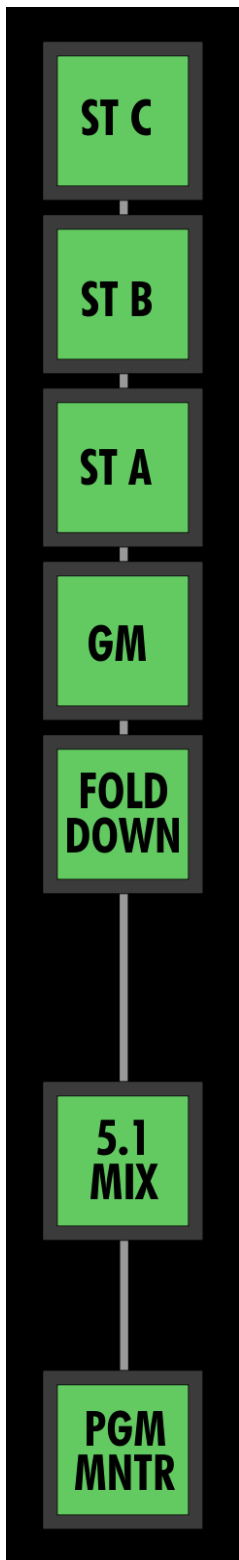

**ST C (Stereo C):** Selects the output of stereo program master C as the program monitor source

- Illuminates in green when engaged

**ST B (Stereo B):** Selects the output of stereo program master B as the program monitor source

- Illuminates in green when engaged

**ST A (Stereo A):** Selects the output of stereo program master A as the program monitor source

- Illuminates in green when engaged

**GM (Grand Master):** Selects the output of stereo grand master as the program monitor source

- Illuminates in green when engaged

**FOLD DOWN:** Selects the output of Lt Rt Fold Down Matrix as the Program Monitor source

- Illuminates in green when engaged

**5.1 MIX:** Selects the output of 5.1 surround masters as the program monitor source

- Illuminates in green when engaged

**PGM MNTR (Program Monitor):** Routes the selected program master or fold down to the control room monitor feed

- Illuminates in green when engaged

To select one of the record/playback devices as the control room monitor source, the **PLAY MNTR** (Playback Monitor) switch must be engaged. The selected playback source will be routed to the control room monitor feed.

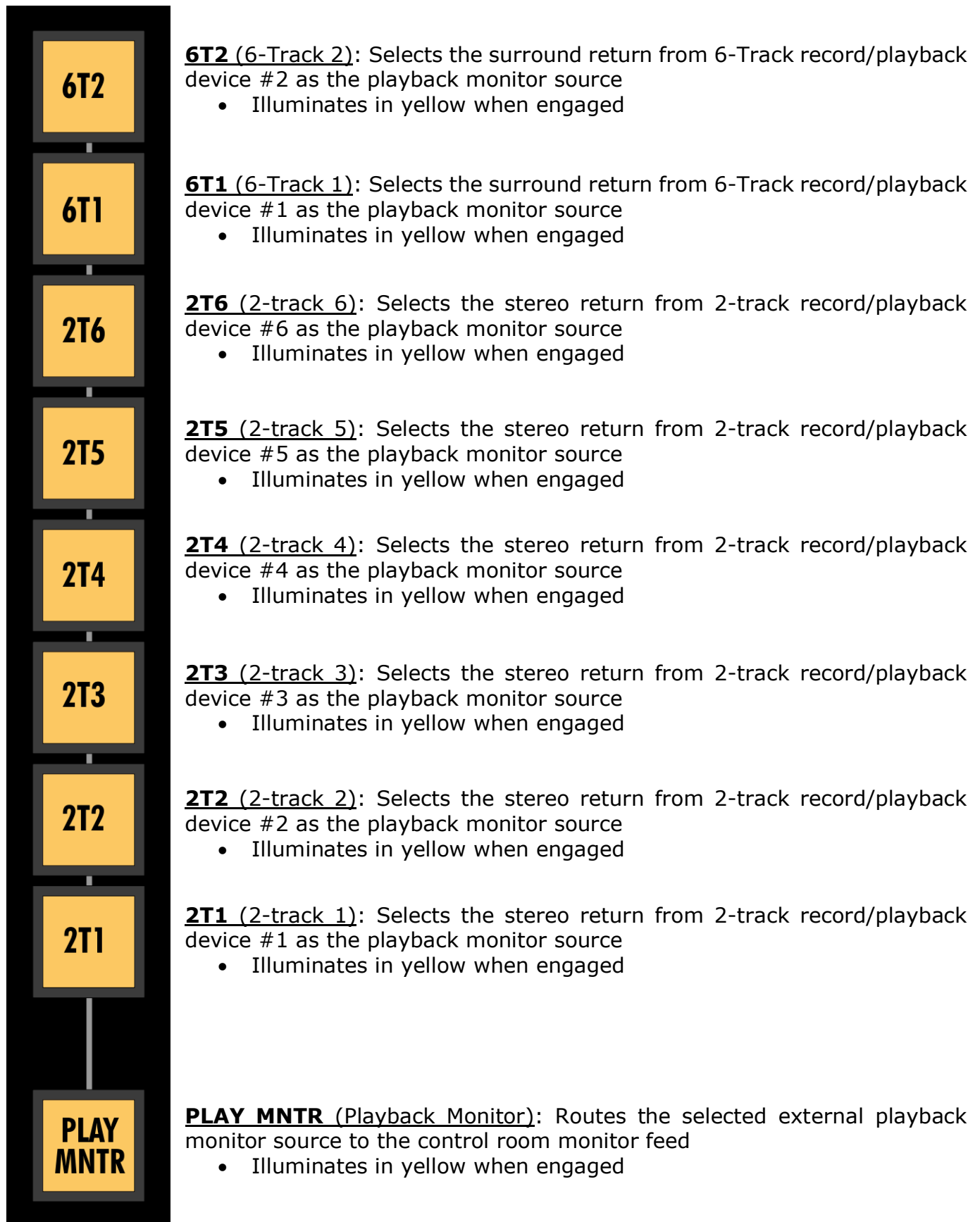

The selected control room monitor source may be locked by engaging the **SEL LOCK** switch.



**SEL LOCK** (Selection Lock): Locks the selected control room monitor source

- Prevents the control room monitor source from being changed
- Illuminates in red when engaged



**C/R LEVEL** (Control Room Level): Main level control for the selected control room monitor system

- $-\infty$ dB to 0dB range
- Fed from the monitor source selectors
- Alternate monitor systems 1 and 2 have individual level trims

### 13.3.2 LFE TO LCR

The output of the LFE filter can be added to the L, C, R control room monitor outputs when monitoring a surround source. Using this feature a surround mix can be checked as if a subwoofer is not connected.



**LFE TO LCR**: Adds the output of the LFE filter to the L, C, R control room monitor outputs

- Illuminates when engaged

# 13.4 Control Room Monitor System Selection

Vision+ consoles supports up to three (3) complete 5.1 surround control room monitoring systems. The left and right speakers for the active system are used for stereo monitoring.

The subwoofer can be enabled for monitoring stereo sources. This will feed the subwoofer a sum of the stereo left and right monitor outputs. Like all monitor outputs, the subwoofer feed can be independently cut.

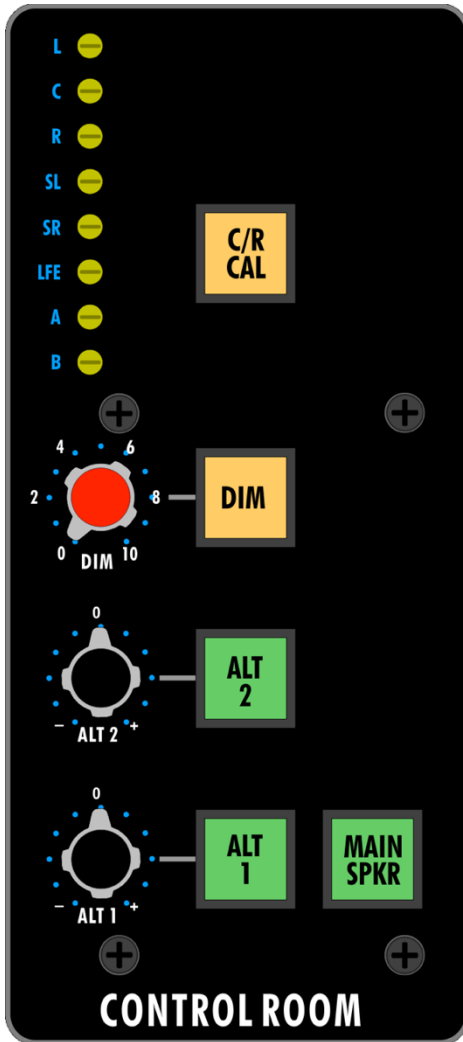

The **CONTROL ROOM** section of the center section contains the primary controls for the three (3) control room monitor systems:

- **MAIN SPKR (Main Speakers):** Main control room monitor system
- **ALT 1 (Alternate 1):** First alternate control room monitor system (mid-fields or near-fields)
- **ALT 2 (Alternate 2):** Second alternate control room monitor system (near-fields)

ALT 1 and 2 have trim controls for level matching between the three systems.

A calibrated control room monitor level (85dB typical) may be set for film work and other purposes. The preset level is activated by engaging the **C/R CAL** (control room calibrate) switch.

A monitor DIM control with variable level can be applied to the active control room monitor system.

## 13.4.1 Control Room Monitor Controls



**MAIN SPKR** (Main Speakers): Routes the selected monitor source to the main control room monitor system

- Illuminates in green when engaged

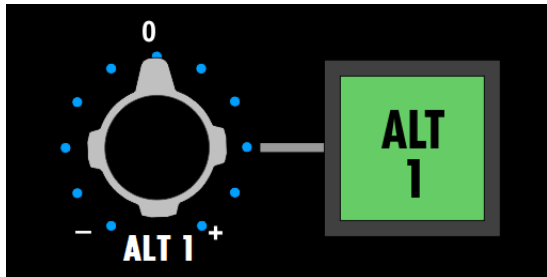

**ALT 1** (Alternate 1) switch: Routes the selected monitor source to the Alternate 1 monitor system

- Replaces current monitor selection
- Illuminates in green when engaged

**ALT 1** (Alternate 1) trim: Trims the output level of the alternate control room monitor system #1

- $-\infty$ dB to +14dB range
- 0dB equals unity gain

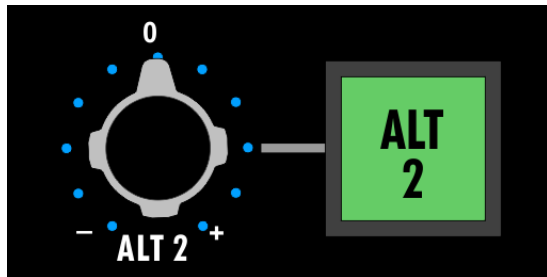

**ALT 2** (Alternate 2) switch: Routes the selected monitor source to the Alternate 2 monitor system

- Replaces current monitor selection
- Illuminates in green when engaged

**ALT 2** (Alternate 2) trim: Trims the output level of the alternate control room monitor system #2

- $-\infty$ dB to +14dB range
- 0dB equals unity gain

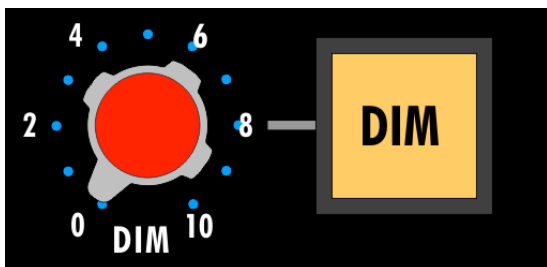

**DIM** switch: Activates the control room monitor dim function

- Attenuates the active control room monitors by the amount set by the **DIM** level potentiometer
- Illuminates in yellow when engaged

**DIM** Level: Sets the amount of attenuation applied when the **DIM** switch is engaged



**C/R CAL** (Control Room Calibration): Activates a preset level for the active control room monitor system

- Bypasses the **C/R LEVEL** control room monitor level control
- The calibrated level for each speaker feed is set with trim-pots
- Illuminates in yellow when engaged



**C/R CAL** (Control Room Calibration) trim-pots: Sets the level of each surround speaker feed when the **C/R CAL** switch is engaged.

Each speaker feed has an individual solo and cut function.

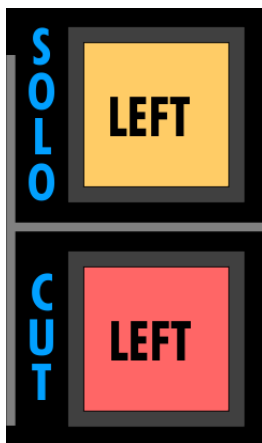
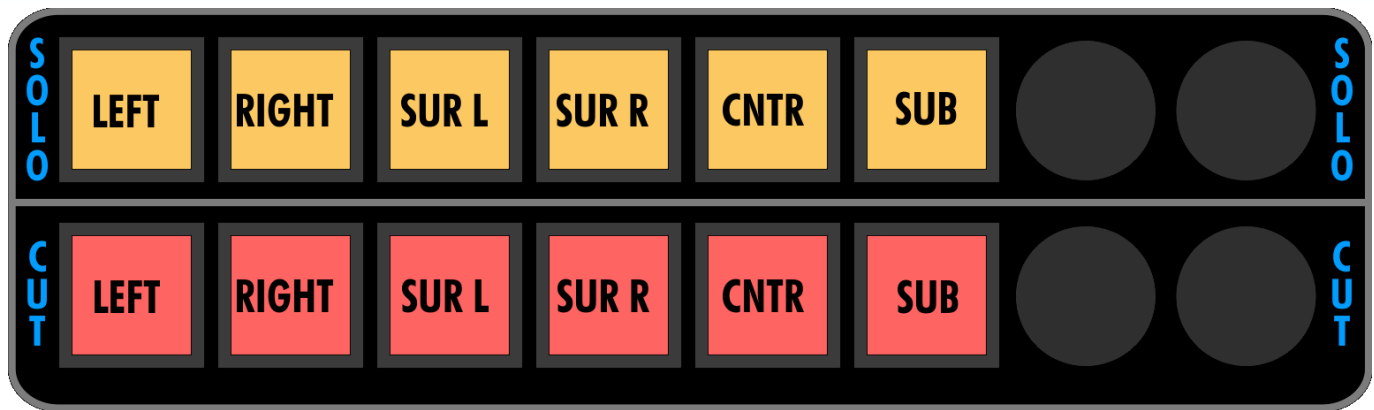

**SOLO:** Solos the selected monitor output

- Mutes speaker feeds that are not soloed
- Illuminates in yellow when engaged

**CUT:** Mutes the selected monitor output

- Illuminates in red when engaged

Control room **CUT** switches are linked to the control room monitor source selectors. The **CUT** switches will engage automatically depending on the selected control room monitor source. If a surround source is selected, all monitor outputs will be uncut.

If a stereo source is selected the **SUR L**, **SUR R**, and **CNTR** monitor feeds will be cut. The **LEFT**, **RIGHT**, and **SUB** outputs will not cut. This allows the subwoofer can be used with main and alternate control room speakers when monitoring a stereo source. As mentioned previously, when a stereo control room monitor source is selected, an unfiltered sum of the stereo left and right monitor outputs will be fed to the subwoofer output. Like all monitor outputs, the subwoofer output can be independently cut.



**ALL CUT:** Cuts the feed to all control room monitor feeds

- Illuminates in red when engaged



**FRONT MONO:** Sums the left, center, and right speaker feeds to mono

- Left and right speaker feeds are summed to mono when monitoring a stereo source
- Illuminates in red when engaged

A square icon with a red background and a black border. The text "REAR MONO" is written in bold, black, uppercase letters, stacked vertically.

**REAR MONO**: Sums the surround left and surround right speaker feeds to mono

- Illuminates in red when engaged

A square icon with a red background and a black border. The text "FLIP FR/R" is written in bold, black, uppercase letters, stacked vertically.

**FLIP FR/R** (Flip Front/Rear): Reverses the front and rear speaker feeds

- The front speaker feeds are routed to the rear speakers
- The rear speaker feeds are routed to the front speakers
- Illuminates in red when engaged

# 13.5 Monitor Output Test Points

A set of test points (+ and -) are located in the center section for control room monitor output calibration.



**C/R TEST POINTS (selector):** Selects the monitor output for measurement

- L = Left
- C = Center
- R = Right
- SL = Surround Left
- SR = Surround Right
- LFE = Subwoofer

**C/R TEST POINTS (jacks):** Banana jacks for testing the selected monitor output feed

- **Black:** Negative
- **Red:** Positive

# 13.6 Control Room Monitor Patch Points

## Program Monitor Selector Patch Points

For clarity purposes, the Control Room Program and Playback monitor source selectors and their associated patch points are shown together.

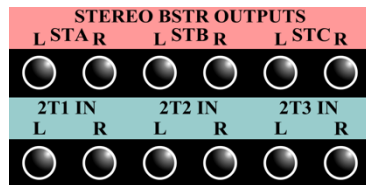

**STEREO BSTR OUTPUTS (Stereo Booster Outputs):** Feeds STA, STB, and STC (Stereo A, B, and C) program monitor selectors

- Outputs from the stereo master fader boosters
- Post master fader
- Half-normalled to 2T1-2T3 IN external recorder inputs



**GM BSTR OUT (Grand Master Booster Outputs):** Feeds the stereo grand master program monitor selector

- Outputs from the stereo grand master fader boosters
- Post master fader
- Half-normalled to 2T4 IN external recorder inputs



**Lt Rt OUT (Left Total-Right Total Outputs):** Feeds the fold down program monitor selector

- Outputs from surround to stereo fold down matrix
- Also feeds the GM Selector

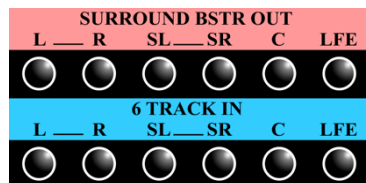

**SURROUND BSTR OUT (Surround Booster Outputs):** Feeds the 5.1 MIX program monitor selector

- Outputs from the surround master fader boosters
- Surround master faders
- Half-normalled to the external 6-track recorder input

## Playback Monitor Selector Patch Points

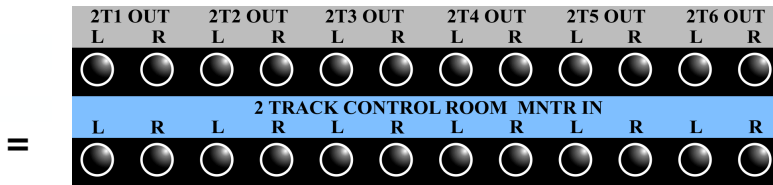
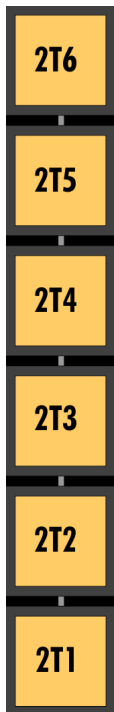

2T 1-6 OUT (2-Track Outputs 1-6): Stereo returns from the external 2-Track record/playback device outputs

- Half-normalled to 2 TRACK 1-6 CONTROL ROOM MNTR IN
- EDAC connection for studio integration

2 TRACK CONTROL ROOM MNTR IN (2-Track Control Room Monitor Inputs): Feeds the control room monitor stereo playback source selectors

- Feeds the 2T1, 2T2, 2T3, 2T4, 2T5, and 2T6 playback monitor source selectors
- Half-normalled from 2T 1-6 OUT
- Patching to these points will replace the feed to the 2-track monitor selectors with the patch cord signal

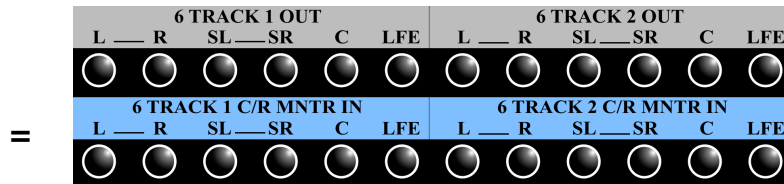

6 TRACK 1-2 OUT (6-Track Outputs 1 and 2): 5.1 surround returns from the external 6-Track record/playback device outputs

- Half-normalled to 6 TRACK 1-2 CONTROL ROOM MNTR IN
- EDAC connection for studio integration

6 TRACK CONTROL ROOM MNTR IN (6-Track Control Room Monitor Inputs): Feeds the control room monitor surround playback source selectors

- Feeds the 6T1 and 6T2 playback monitor source selectors
- Half-normalled from 6 TRACK 1-2 OUT
- Patching to these points will replace the feed to the 6-track monitor selectors with the patch cord signal

## Control Room Monitor Output and Amplifier Input Patch Points



=

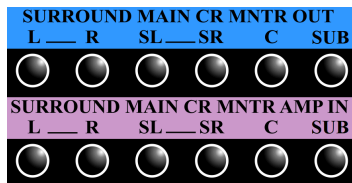

SURROUND MAIN CR MNTR OUT (Surround Main Control Room Monitor Outputs): Control room main monitor output feeds

- Active only when the **MAIN SPKR** (main speakers) switch is engaged
- Half-normalled to SURROUND MAIN CR MNTR AMP IN

SURROUND MAIN CR MNTR AMP IN (Surround Main Control Room Monitor Amplifier Inputs): Feeds the inputs of the amplifiers for the main control room monitor amplifiers

- Half-normalled from SURROUND MAIN CR MNTR OUT
- Patching to these points will replace the feed to the main monitor amps with the patch cord signal
- EDAC connection for studio integration

**CAUTION: Extreme caution should be used when patching into the SURROUND MAIN CR MNTR AMP IN patch points as these patches bypass the control room volume control.**

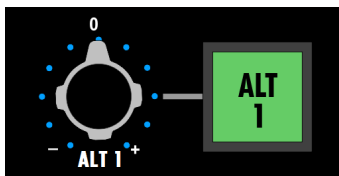

=

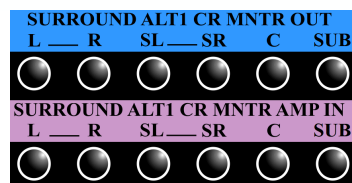

SURROUND ALT1 CR MNTR OUT (Surround Alternate 1 Control Room Monitor Outputs): #1 alternate control room monitor output feeds

- Active only when the **ALT 1** (main speakers) switch is engaged
- Half-normalled to SURROUND ALT1 CR MNTR AMP IN

SURROUND ALT1 CR MNTR AMP IN (Surround Alternate 1 Control Room Monitor Amplifier Inputs): Feeds the inputs of the amplifiers for the #1 alternate control room monitors

- Half-normalled from SURROUND ALT1 CR MNTR OUT
- Patching to these points will replace the feed to the main monitor amps with the patch cord signal
- EDAC connection for studio integration

**CAUTION: Extreme caution should be used when patching into the SURROUND ALT1 CR MNTR AMP IN patch points as these patches bypass the control room volume control.**



=

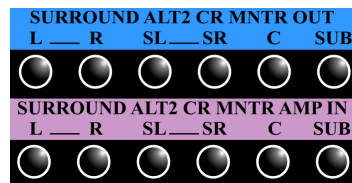

SURROUND ALT2 CR MNTR OUT (Surround Alternate 2 Control Room Monitor Outputs): #2 alternate control room monitor output feeds

- Active only when the **ALT 2** (main speakers) switch is engaged
- Half-normalled to SURROUND ALT2 CR MNTR AMP IN

SURROUND ALT2 CR MNTR AMP IN (Surround Alternate 2 Control Room Monitor Amplifier Inputs): Feeds the inputs of the amplifiers for the #2 alternate control room monitors

- Half-normalled from SURROUND ALT2 CR MNTR OUT
- Patching to these points will replace the feed to the main monitor amps with the patch cord signal
- EDAC connection for studio integration

**CAUTION: Extreme caution should be used when patching into the SURROUND ALT2 CR MNTR AMP IN patch points as these patches bypass the control room volume control.**

# 14.0 Studio Monitor Control

Vision+ consoles provide comprehensive studio monitor control facilities.

Features include:

- Support for up to two (2) complete stereo/surround studio monitor systems
- Program monitoring (follows control room selection)
  - Five (5) stereo program sources
  - One (1) 5.1 surround program source
- Playback monitoring (follows control room selection)
  - Six (6) external stereo playback sources
  - Two (2) 5.1 external surround playback sources
- One (1) external 5.1 surround playback source via patch
- Studio monitor level control and cut function

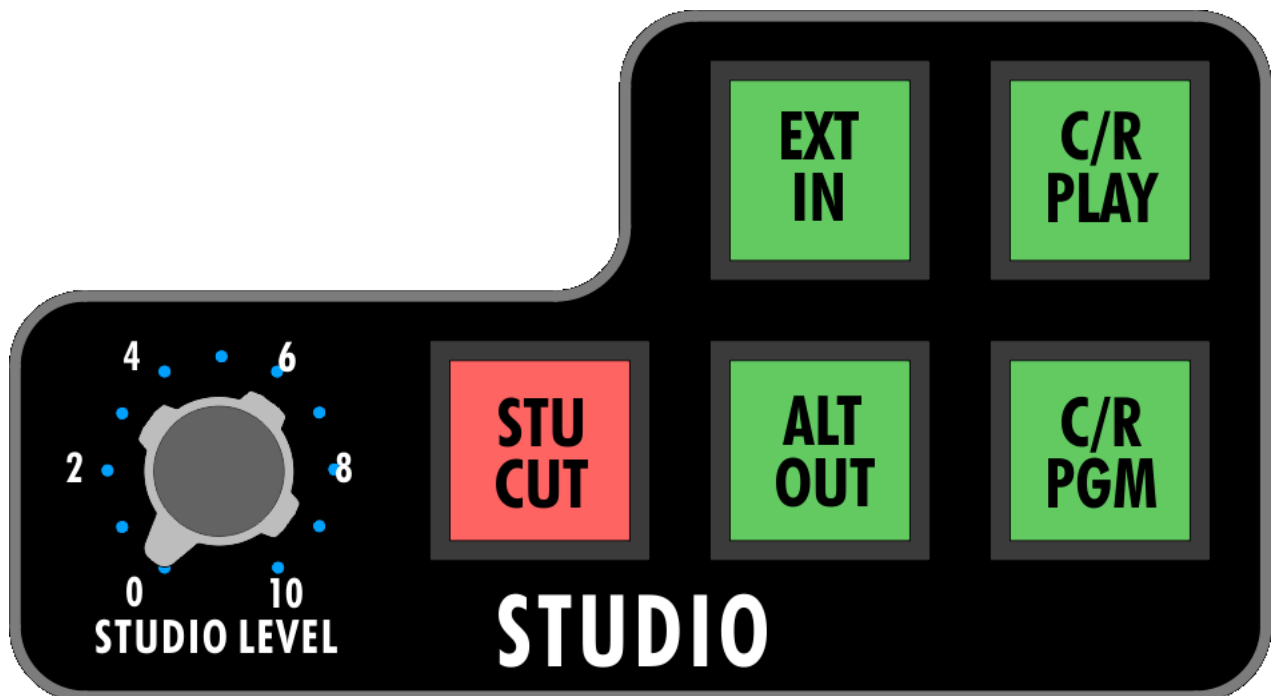

## 14.1 Studio Stereo and Surround Monitoring

Support is provided for two (2) complete stereo/surround studio monitoring systems, main and alternate in the **STUDIO** section of the monitor controls. The left and right speakers for the active system are used for stereo monitoring.

The source for stereo monitoring may be selected from three (3) primary sources:

- **C/R PLAY**: The selected control room playback source
- **C/R PGM**: The selected control room program source
- **EXT IN**: External input via patch

The following control room monitor sources may be select for studio monitoring:

**Selected Control Room Program Source:**

- Stereo A (**ST A**)
- Stereo B (**ST B**)
- Stereo C (**ST C**)
- Stereo grand master (**GM**)
- Lt Rt surround fold down (**FOLD DOWN**)
- Surround program (**5.1 MIX**)

**Selected Control Room Playback Source:**

- Two-track 1 (**2T 1**)
- Two-track 2 (**2T 2**)
- Two-track 3 (**2T 3**)
- Two-track 4 (**2T 4**)
- Two-track 5 (**2T 5**)
- Two-track 6 (**2T 6**)
- Six-track 1 playback (**6T 1**)
- Six-track 2 playback (**6T 2**)

**External Input:**

- External stereo or 5.1 surround source via patch

## 14.2 Studio Monitor Controls



**C/R PGM** (Control Room Program): The selected control room program source is routed to the studio monitor feed

- Changing the control room monitor program source will change the will also change the feed to the studio monitors when **C/R PGM** is engaged
- Illuminates in green when engaged



**C/R PLAY** (Control Room Playback): The selected control room playback source is routed to the studio monitor feed

- Changing the control room monitor playback source will change the will also change the feed to the studio monitors when **C/R PLAY** is engaged
- Illuminates in green when engaged



**EXT IN** (External Input): The signal from the STUDIO SURROUND EXT MNTR IN patch points is routed to the Studio monitor feed when **EXT IN** is engaged

- Illuminates in green when engaged



**ALT OUT** (Alternate Output): Activates the alternate studio monitor outputs

- Routes the selected Studio monitor source to the SURROUND ALT STUDIO MNTR AMP IN patch points
- The feed to the main studio monitors is not cut
- Illuminates in green when engaged



**STUDIO LEVEL:** Level control for the studio monitor outputs

- Sets the level for the main and alternate studio monitor outputs
- Fed from the studio monitor source selectors



**STU CUT (Studio Cut):** Cuts the feed to all studio monitor feeds

- Talkback to Studio monitors is disabled when STU CUT is engaged
- Illuminates in red when engaged

## 14.3 Studio Monitor Patch Points



STUDIO SURROUND EXT MNTR IN (Studio Surround External

Monitor Input): External studio monitor surround inputs

- Allows an external stereo or surround source to be routed to the studio monitor EXT IN source selector
- Active only when the **EXT IN** switch in the studio monitor controls is engaged

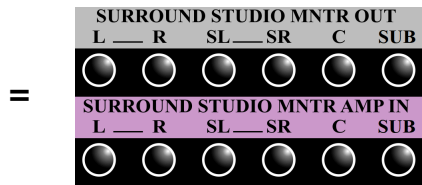

SURROUND STUDIO MNTR OUT (Surround Studio Monitor

Outputs): Main studio monitor output feeds

- Half-normalled to SURROUND STUDIO MNTR AMP IN

SURROUND STUDIO MNTR AMP IN (Surround Studio Monitor

Amplifier Inputs): Feeds the inputs of the studio monitor amplifiers

- Half-normalled from SURROUND STUDIO MNTR OUT
- Patching to these points will replace the feed to the Studio monitor amps with the patch cord signal
- EDAC connection for studio integration

**CAUTION:** Extreme caution should be used when patching into the **SURROUND STUDIO MNTR AMP IN** patch points as these patches bypass the control room volume control.

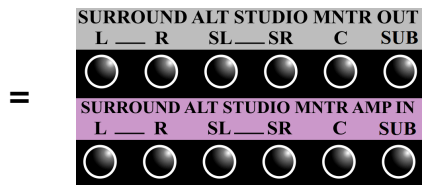

SURROUND STUDIO MNTR OUT (Surround Studio Monitor

Outputs): Main studio monitor output feeds

- Half-normalled to SURROUND STUDIO MNTR AMP IN

SURROUND STUDIO MNTR AMP IN (Surround Studio Monitor

Amplifier Inputs): Feeds the inputs of the studio monitor amplifiers

- Half-normalled from SURROUND STUDIO MNTR OUT
- Patching to these points will replace the feed to the Studio monitor amps with the patch cord signal
- EDAC connection for studio integration

**CAUTION:** Extreme caution should be used when patching into the **SURROUND ALT STUDIO MNTR AMP IN** patch points as these patches bypass the control room volume control.

# 15.0 Sine Wave Oscillator

Vision+ consoles are equipped with a sine wave **OSCILLATOR** to generate test-tones for calibration and trouble-shooting.

The oscillator has the following features:

- Sine wave
- Eight (8) selectable frequencies
- 20Hz to 15kHz
- Output level control

The oscillator can be routed to feed:

- Multitrack summing buses 1-24
- All stereo and surround program buses
- Patch point (when **ON** is engaged)

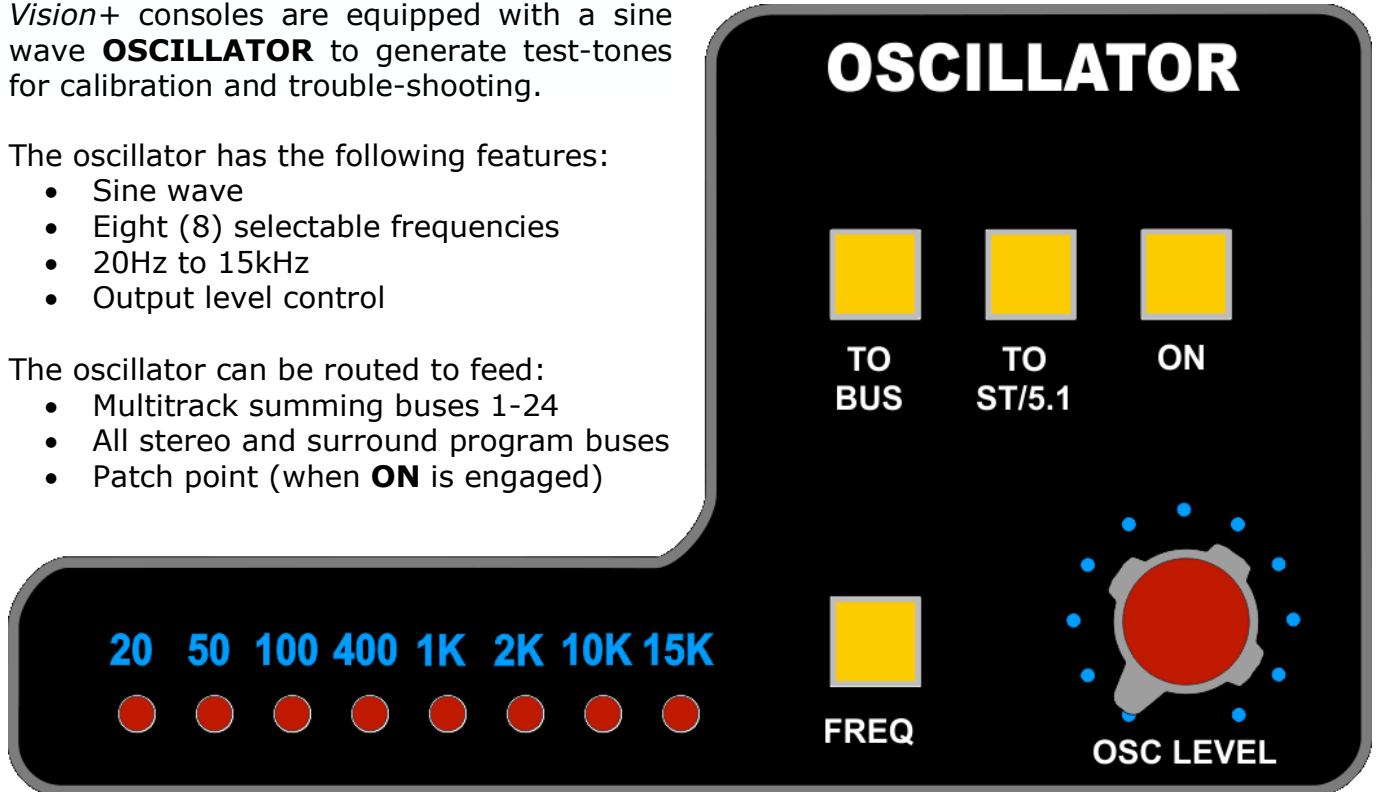

## 15.1 Oscillator Controls

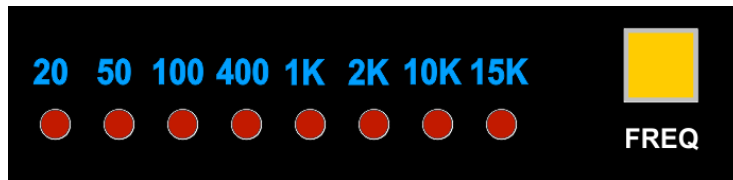

**FREQ (Frequency):** Selects the oscillator frequency

- 8 frequencies: 20Hz, 50Hz, 100Hz, 400Hz, 1kHz, 2kHz, 10kHz, and 15kHz
- Illuminates in yellow when pressed



**TO BUS:** Routes the oscillator output to multitrack summing buses 1-24

- Illuminates in yellow when engaged



**TO ST/5.1 (Stereo/5.1):** Routes the oscillator output to all stereo and surround program buses.

- Illuminates in yellow when engaged



**ON:** Activates the sine wave Oscillator

- Dims the control room monitors when engaged
- Feeds the OSC OUT patch point when engaged
- Illuminates in red when engaged



**OSC LEVEL (Oscillator Level):** Sets the output level of the oscillator

**CAUTION:** Exercise great care when activating and routing the oscillator. Cue systems and studio monitors should be CUT and the control room monitors should be turned down to a low level and/or dimmed.

## 15.2 Oscillator Patch Point



**OSC OUT (Oscillator Output):** Output of the oscillator

- Active when either the oscillator **ON** switch is engaged

## 16.0 User Switches

Four (4) programmable **USER** switches are provided to facilitate custom features. The programming of these switches is unique to each installation and is determined at the time of console specification. Please refer to the facilities engineering documentation and staff for details of the specific studio application.

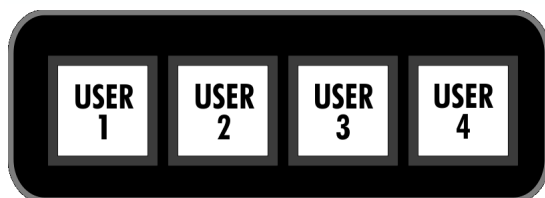

**USER 1-4:** Activates a contact closure when engaged

- Programmable momentary or latching function
- Illuminates when engaged

# 17.0 Meters and Peak Indicators

*Vision+* consoles are equipped with the following options for monitoring levels:

- Channel VU meter bridge
- Channel peak indicators
- Main VU meters
- Module meters

In combination, these meter options provide a complete suite of metering tools for any application.

Auxiliary send output levels are displayed on the 5-segment LED meter on each 227L module.

The following 200L modules have built-in 5-segment LED output meters:

- 205L Direct Input
- 212L Microphone Preamp
- E1068L Surround Effect Return

The following 200L modules have built-in 5-segment LED gain reduction meters:

- 225L Compressor/Limiter
- 235L Noise Gate/Expander

## 17.1 VU Meter Bridge

With the exception of the power supply LED indicators, the *Vision+* meter bridge is populated only with VU meters.

The meter bridge provides the ability to monitor the levels of the following signal paths:

- Channel level (Fader 1, Fader 2, and direct out)
- Multitrack summing bus outputs
- Selected control room monitor source:
  - Stereo program masters
  - Surround program masters
  - Stereo and surround playback sources
- Solo bus
- Lt Rt fold down

The meter bridge has two sections:

- Channel Meters: 16-channel VU meter bridge for each channel bucket
- Main Meters: Large center section VU meters for main outputs

## 17.1.1 Channel Meters

The channel meters are organized in banks of sixteen (16), one for each channel bucket.

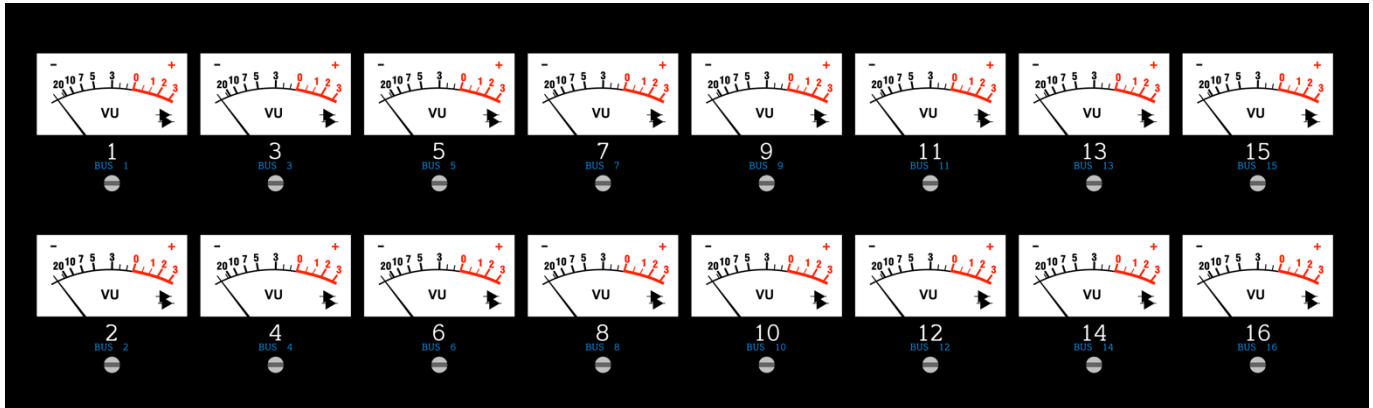

The channel meters are stacked in pairs with 1 over 2, 3 over 4, and so on.

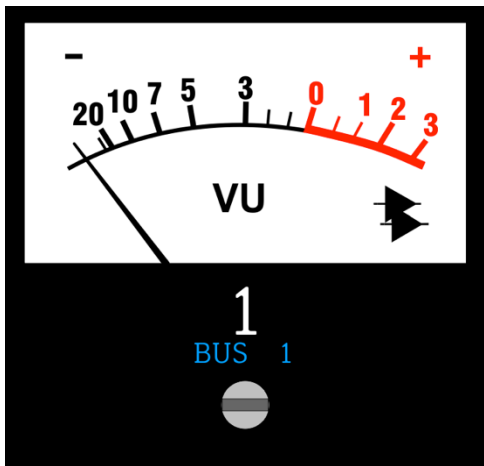

Each channel meter can be fed from the following points:

- Fader 1 channel input
- Fader 2 channel input
- Direct output
- Multitrack summing bus 1-24

See section 17.1.3 for channel meter source selection.

## 17.1.2 Main Meters

A full set of main meters is installed above the master faders and center section.

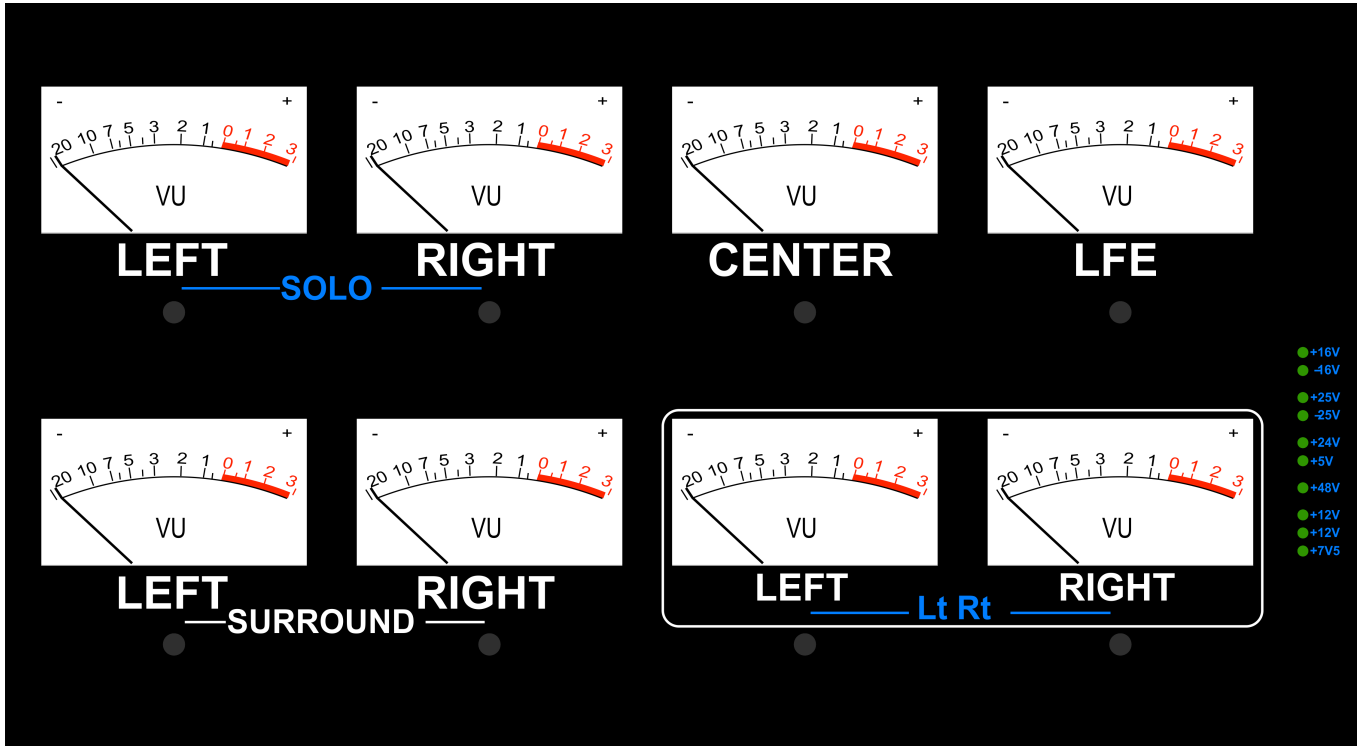

The main meters can be fed from the following sources:

- The selected control room monitor source (default)
  - Stereo program grand master outputs
  - Stereo program master A, B, or C outputs
  - Surround program master outputs
  - Lt Rt fold down matrix outputs
- Solo bus (when a AFL, PFL, or MIX OVER SOLO is engaged)

The main meters are organized as follows:

- LEFT and RIGHT (**SOLO**)
- CENTER
- LFE
- SURROUND LEFT and SURROUND RIGHT
- LEFT and RIGHT (**Lt Rt**)

Under normal circumstances, the main meters display the level of the selected control room monitor source.

The LEFT and RIGHT (**SOLO**) meters are used for stereo only applications.

When a PFL or AFL **SOLO** is engaged, the LEFT and RIGHT (**SOLO**) meters display the output of the solo bus.

The LEFT and RIGHT (Lt Rt) meters display the output of the surround to stereo fold down matrix. When the output of the Lt Rt fold down is engaged, the LEFT and RIGHT (Lt Rt) meters display the Left Total and Right Total output of the matrix.

A -10 dB attenuator can be inserted before the main meters (**MAIN VU 0=+10**) for better resolution of high-level signals.

The ballistics of the main meters can be changed from VU to peak hold (**MAIN VU PEAK**).

### 17.1.3 Meter Controls (METER SELECT)

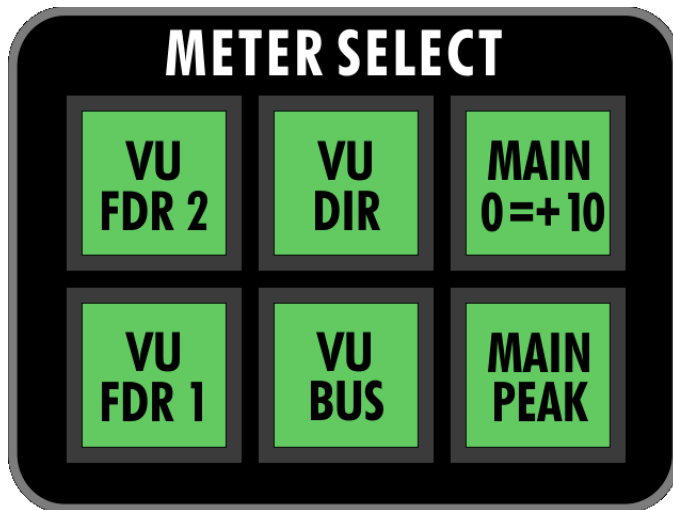

**METER SELECT:** The feeds to the channel meters and main meter ballistics are determined by the **METER SELECT** controls in the center section.

The **METER SELECT** controls function as follows:



**VU FDR 2 (Fader 2):** Assigns the meters to the Fader 2 channel input

- Illuminates in green when engaged



**VU FDR 1 (Fader 1):** Assigns the meters to the Fader 1 channel input

- Illuminates in green when engaged



**VU DIR (Direct Output):** Assigns the meters to the channel direct output

- Illuminates in green when engaged



**VU BUS (Multitrack Summing Buses 1-24):** Assigns the meters to the outputs of multitrack summing buses 1-24

- Channel meters 1-24 only
- Illuminates in green when engaged



**MAIN VU 0 = +10:** Sets the main meters VU scale to 0VU equals +14dBu

- A -10dB pad is inserted before the meter
- 0VU equals +14dBu when engaged
- 0VU equals +4dBu when not engaged
- Illuminates in green when engaged



**MAIN VU PEAK:** Changes the main meter ballistics from VU to peak

- A fixed peak hold circuit feeds the meter
- Illuminates in green when engaged

## 17.2 1068L Channel Peak Indicators

Each 1068L is equipped with two LED peak indicators, one in each audio path, Fader 1 and Fader 2. The peak reference level is selected by the **PEAK REFERENCE** control in the center section.



**PEAK:** The red LED illuminates when the **PEAK REFERENCE** level is reached in the respective audio path, Fader 1 or Fader 2

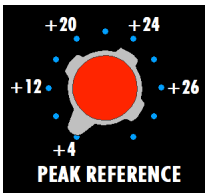

**PEAK REFERENCE:** Sets the peak reference level for all channel peak indicators (both audio paths)

- +4dBu to +28dBu Range
- Continuously variable potentiometer

## 17.3 Power Supply Voltage Indicators

*Vision+* consoles are equipped with LED power supply voltage indicators that provide a quick visual indication of the console status and are mostly used in maintenance and troubleshooting applications.



The power supply LED indicators are located next to the main meters and display the following voltages:

- +16 volts
- -16 volts
- +25 volts
- -25 volts
- +24 volts
- +5 volts
- +48 volts
- +12 volts
- +12 volts
- +7.5 volts

The power supply LEDs are green when the voltage is normal and red when the voltage is out of range.



# 18.1 Patch Bay Normalising Conventions

Patch bay “normals” are used to facilitate typical signal through the console and studio. For example, the DIRECT OUTPUT patch points are “normally” patched to the MULTITRACK INPUTS for most applications, so the patch bay is internally wired to make this and other normally used connections so extensive patching can be avoided.

Two types of patch bay normals are employed: half-normals and full-normals. The behavior of each is determined by their application and are describe as follows:

**Half-Normalled Outputs:** All line-level output patch points are half-normalled to their functional destinations. Their signals are “split” when a patch cord is inserted. In other words, when a patch cord is inserted in a line-level output, the signal is available at the patch cord, but it also continues to its normalled destination, in essence creating a “Y-cord.”

**Full-Normalled Outputs:** Only the MIC TIE-LINE patch points are full-normalled to their functional destinations, the MIC PREAMP INPUTS. Their signals are “broken” when a patch cord is inserted. In other words, when a patch cord is inserted in a MIC TIE-LINE, the signal is available at the patch cord, but does not continue to the MIC PREAMP INPUTS.

*NOTE: The MIC TIE-LINE patch points are the only patch points that “break” when a patch cord is inserted.*

**Half and Full-Normalled Inputs:** All half and full-normalled input patch points “break” when a patch cord is inserted. In other words, the signal is received from the inserted patch cord and does not get its signal from its normalled source. The connection with its normalled source is broken.

# 18.2 Channel Patch Points

There is a comprehensive set of patch points associated with the complete *Vision+* channel including (a 32-channel bay is shown below):

- Microphone tie-lines
- Upper 200L slots (preamp inputs and outputs)
- Lower 200L slots (dynamics inputs and outputs)
- 500L EQ slot (equalization inputs and outputs)
- Fader 1 and Fader 2 insert (sends and returns)
- 1068L module Fader 1 and Fader 2 audio path inputs
- Fader 1 and Fader 2 fader inputs
- Direct outputs
- Primary DAW/multitrack recorder inputs and outputs
- Alternate DAW/multitrack recorder outputs

## Channel Patch Bay



### 18.2.1 Channel Patch Point Details and Normals

There is an extensive set of patch points associated with the *Vision+* channel strip including:

- Microphone tie-lines
- Upper 200L slots (preamp)
- Lower 200L slots (dynamics)
- 500L EQ slot
- 1068L input module (Fader 1 and Fader 2 audio path)
- Direct outputs
- Primary multitrack recorder inputs and outputs
- Alternate multitrack recorder outputs

The following section outlines the channel patch points for each audio path in default signal flow order.

**IMPORTANT NOTE:** To accommodate the space restrictions of this manual, only the first eight (8) Patch Points are shown for each row and a smaller font is used in the following section. The total number of channel points in an actual patch bay will be determined by frame size. For example, the channel bays for a 48-channel frame will accommodate 48 sets of channel patch points.

## 18.2.2 Mic Path and Fader 2 Patch Points

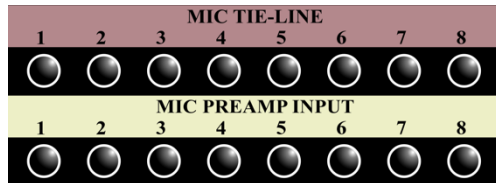

**MIC TIE LINE:** Studio microphone tie-line outputs

- Fully-normalled to MIC PREAMP INPUT
- EDAC connection for studio integration

**MIC PREAMP INPUT:** Upper 200L slot module input

- Fully-normalled from MIC TIE LINE
- Patching will replace the MIC TIE-LINE feed to the preamp
- **CAUTION:** Can carry 48v phantom power

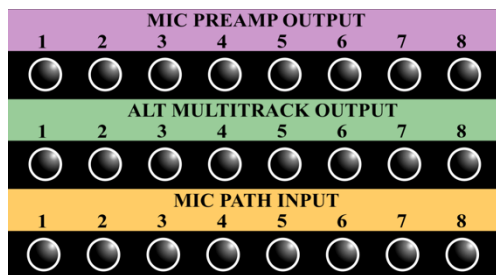

**MIC PREAMP OUTPUT:** Upper 200L slot module output

- Half-normalled to MIC PATH INPUT

**ALT MULTITRACK OUTPUT:** Alternate DAW/multitrack output

- Replaces MIC PATH signal when **ALT LINE** switch is engaged
- EDAC connection for studio integration

**MIC PATH INPUT:** Input to the MIC PATH front-end signal flow

- Feeds the Fader 2 audio path by default
- Also selectable as the Fader 1 audio path input
- Feeds DYNAMICS INPUT by default

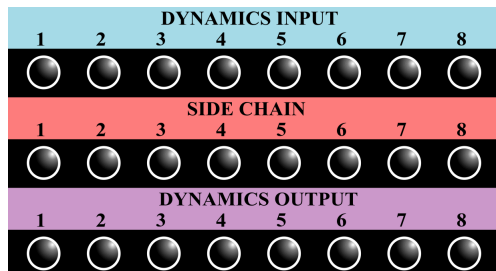

**DYNAMICS INPUT:** Lower 200L slot module input (often 225L Compressor)

- Fed from Fader 2 mic/**LINE** switch
- Half-normalled to SIDE CHAIN

**SIDE CHAIN:** Lower 200L slot module side chain or key input

- Half-normalled from DYNAMICS INPUT

**DYNAMICS OUTPUT:** Lower 200L slot module output

- Feeds the FADER 2 INSERT SEND in the Mic Path

**NOTE:** Engaging the **DYN TO FDR1** switch will move the lower 200L slot to the LINE PATH (Fader 1) before the EQ.

**NOTE:** Patching into the **SIDE CHAIN** input will replace the **DYNAMICS INPUT** as the source for the module's detection path (side-chain).

**NOTE:** When a 225L Compressor/Limiter is installed in the lower 200L slot, the **SIDE CHAIN** patch point is only active when the **NEW TYPE** is selected. This is due to path to the detector circuit being fed after the gain reduction element (VCA) when **OLD TYPE** is selected.

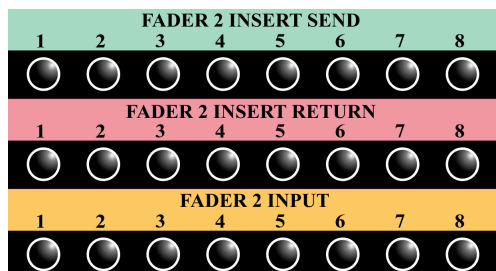

**FADER 2 INSERT SEND:** Fader 2 insert send (always active)

- Half-normalled from DYNAMICS OUTPUT
- Feeds FADER 2 INPUT when the Fader 2 **INS** switch *is not* engaged

**FADER 2 INSERT RETURN:** Fader 2 insert return

- Half-normalled from FADER 2 INSERT SEND
- Feeds channel FADER 2 INPUT when the Fader 2 **INS** switch *is* engaged

**FADER 2 INPUT:** 1068L Fader 2 input

- Half-normalled from FADER 2 INSERT SEND/RETURN

## 18.2.3 Line Path and Fader 1 Patch Points

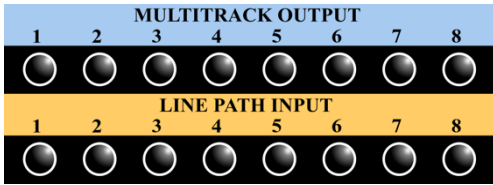

**MULTITRACK OUTPUT:** Primary DAW/multitrack output (multitrack return)

- Half-normalled to the LINE PATH INPUT patch point
- EDAC connection for studio integration

**LINE PATH INPUT:** Input to the LINE PATH front-end signal flow

- Feeds the Fader 1 audio patch by default
- Also selectable for as the Fader 2 input
- Feeds EQ INPUT by default

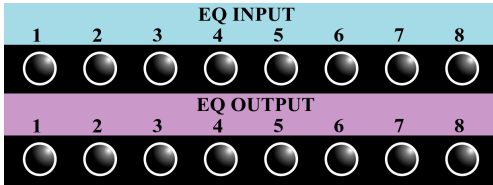

**EQ INPUT:** 500L EQ slot module input

- Fed from Fader 1 line/**MIC** switch

**EQ OUTPUT:** 500L EQ slot module output

- Feeds the FADER 1 INSERT SEND in the Line Path

*NOTE: Engaging the **EQ FDR2** switch will move the 500L EQ slot to the MIC PATH (Fader 2) after the lower 200L slot.*

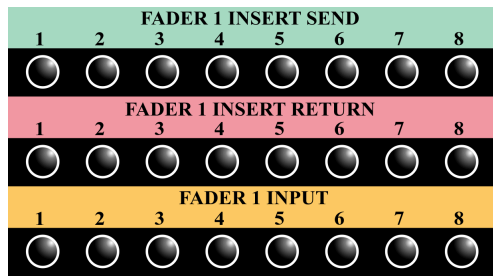

**FADER 1 INSERT SEND:** Fader 1 insert send

- Half-normalled from EQ OUTPUT
- Feeds FADER 1 INPUT when the Fader 1 **INS** switch *is not* engaged Always active
- Always active

**FADER 1 INSERT RETURN:** Fader 1 insert return

- Half-normalled from FADER 1 INSERT SEND
- Feeds channel FADER 1 INPUT when the Fader 1 **INS** switch *is* engaged

**FADER 1 INPUT:** 1068L Fader 1 input

- Half-normalled from FADER 1 INSERT SEND/RETURN

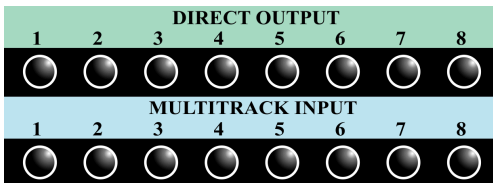

**DIRECT OUTPUT:** Channel direct output

- Fed from FADER 1 by default
- Will be fed from Fader 2 if the **DIR FDR2** switch is engaged
- Half-normalled to MULTITRACK INPUT

**MULTITRACK INPUT:** DAW/multitrack recorder input (multitrack send)

- Half-normalled from DIRECT OUTPUT
- EDAC connection for studio integration

## 18.3 Channel Bay Multitrack Patch Points

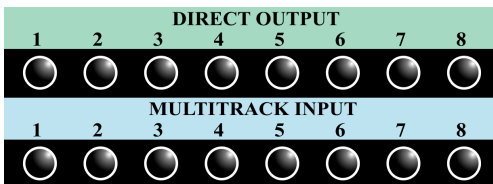

**DIRECT OUTPUT:** Channel direct output

- Fed from FADER 1 by default
- Will be fed from Fader 2 if the **DIR FDR2** switch is engaged
- Half-normalled to MULTITRACK INPUT

**MULTITRACK INPUT:** DAW/multitrack recorder input (multitrack send)

- Half-normalled from DIRECT OUTPUT
- EDAC connection for studio integration

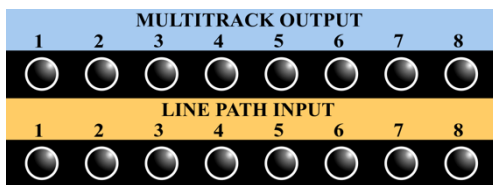

**MULTITRACK OUTPUT:** Primary DAW/multitrack output (multitrack return)

- Half-normalled to the LINE PATH INPUT patch point
- EDAC connection for studio integration

**LINE PATH INPUT:** Input to the LINE PATH front-end signal flow

- Feeds the Fader 1 audio patch by default
- Also selectable for as the Fader 2 input
- Feeds EQ INPUT by default



**ALT MULTITRACK OUTPUT:** Alternate DAW/multitrack output

- Replaces MIC PATH signal when **ALT LINE** switch is engaged
- EDAC connection for studio integration

# 18.4 System Bay 1

## SYSTEM BAY 1

System Bay 1 contains patch points that support the following:

- Options bucket patchpoints
- E1068L surround effects return inputs
- 227L aux send external inputs
- 227L aux send outputs
- Polarity reverse
- Multiples

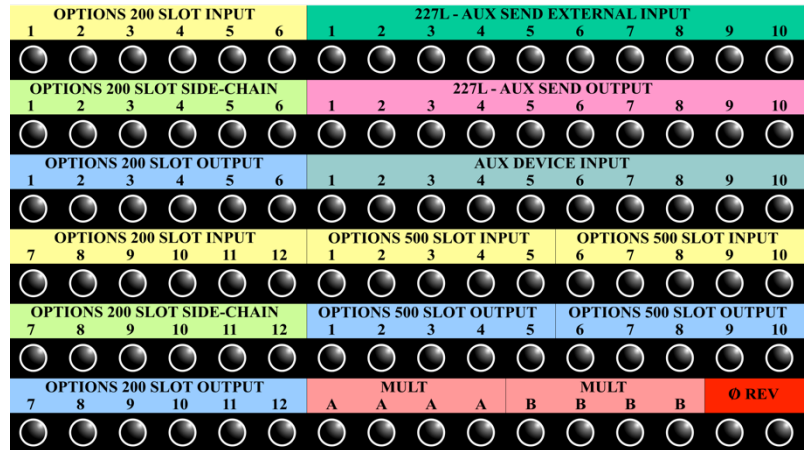

### 18.4.1 Options Bucket Patch Points

The patch points for 200L and 500L modules in the options bucket appear in system patch bay 1. Because most consoles will have a unique set of modules installed in the options bucket, the patch bay will be labeled according to this set of modules. Generic options bucket patch points are shown below.

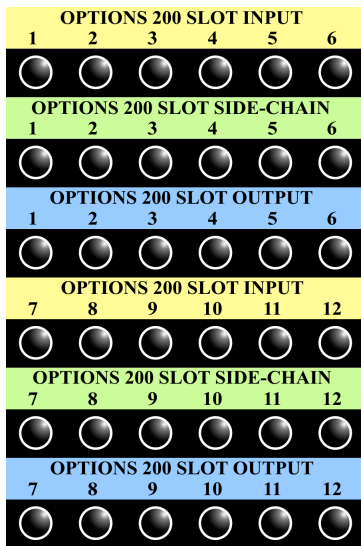

OPTIONS 200 SLOT INPUT: Options bucket 200L slot module inputs

- Half-normalled to OPTIONS 200 SLOT SIDE-CHAIN

OPTIONS 200 SLOT SIDE-CHAIN: Options bucket 200L slot module side-chain inputs

- Half-normalled from OPTIONS 200 SLOT INPUT

OPTIONS 200 SLOT OUTPUT: Options bucket 200L slot module outputs

*NOTE: Patching into the OPTIONS 200 SLOT SIDE-CHAIN will replace the OPTIONS 200 SLOT INPUT as the source for the module's detection path (side-chain input)*

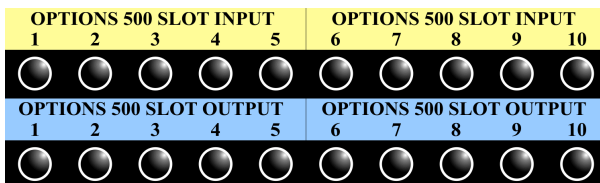

OPTIONS 500 SLOT INPUT: Options bucket 500L slot module inputs

OPTIONS 500 SLOT OUTPUT: Options bucket 500L slot module outputs

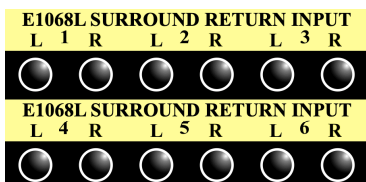

E1068L SURROUND RETURN INPUT 1-6: Inputs to the E1068L modules

- Stereo Left-Right external effects device inputs
- One stereo input per E1068L module

## 18.4.2 Auxiliary Send Patch Points

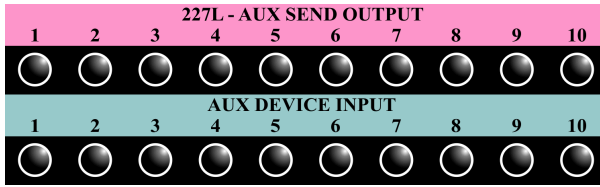

**227L - AUX SEND OUTPUT:** Output of the 227L aux send output modules

- Half-normalled to AUX DEVICE INPUT

**AUX DEVICE INPUT:** Feeds inputs to external effects processors or other destinations

- Half-normalled from 227L AUX SEND OUTPUT
- EDAC connection for studio integration



**227L - AUX SEND EXTERNAL INPUT:** External inputs to the 227L aux send output modules

- Active when the **EXT IN** switch is engaged on the 227L module

## 18.4.3 Phase Reverse and Multiple Patch Points



**Ø REV (Reverse):** The two points are wired out of polarity with each other

- A signal patched into one jack will be out of polarity (phase reversed) at the other point

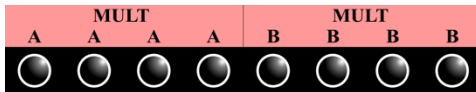

**MULT A and B (Multiple):** Two sets of 4 paralleled patch points

- Hardwired split (no buffer)
- Signals patched into one of these points is available at the other points

## 18.5 System Bay 2

System Bay 2 contains patch points that support the following:

- Stereo program masters
- Surround program masters
- Program and solo bus access inputs
- LFE filter
- External recorder inputs
- Lt Rt fold down matrix
- Studio monitor external ins
- Oscillator output
- Optional 2500+C stereo bus compressor

### SYSTEM BAY 2

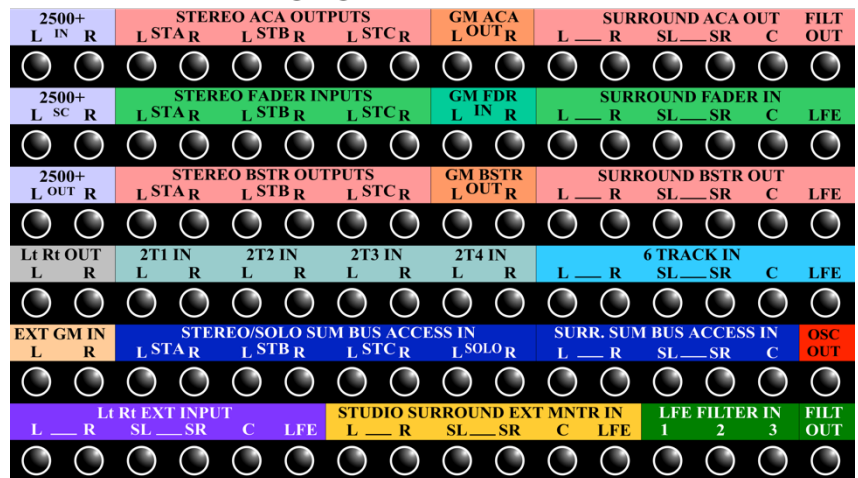

## 18.5.1 Stereo Program Patch Points



**STEREO/SOLO SUM BUS ACCESS IN L-R:** Stereo and solo summing bus access inputs

- Injected into the stereo buses A, B, C, and the solo buses
- Signals patched to these patch points will be added the bus feed before the ACA

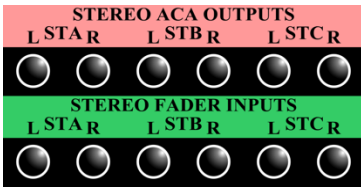

**STEREO ACA OUTPUTS L-R:** Stereo active combining amplifier outputs

- Half-normalled to STEREO FADER INPUTS L-R

**STEREO FADER INPUTS L-R:** Stereo master fader inputs

- Half-normalled from STEREO ACA OUTPUTS L-R
- Patching to these points will replace the feed to the stereo master faders with the patch cord signals

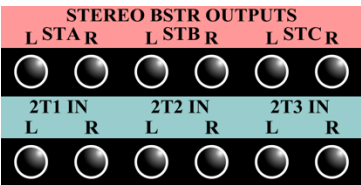

**STEREO BSTR OUTPUTS L-R:** Stereo master fader booster outputs

- Fed from **CAL** trim pot in the master stereo program output modules
- Half-normalled to 2T1 thru 2T3 IN L-R

**2T1 thru 2T3 IN L-R:** Stereo inputs to the 2-track recorder(s) 1 thru 3

- Patching to these points will replace the feed to the 2-track recorder with the patch cord signal
- EDAC connection for studio integration



**GM ACA OUT L-R:** Stereo grand master active combining amplifier output

- Half-normalled to GM FDR IN L-R

**GM FDR IN L-R:** Stereo grand master fader inputs

- Half-normalled from GM ACA OUT L-R
- Patching to these points will replace the feed to the grand master fader with the patch cord signal

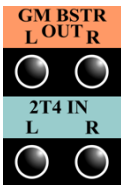

**GM BSTR OUT:** Stereo grand master booster output

- Primary stereo program output
- Half-normalled to 2T4 FEED IN

**2T4 IN L-R:** Stereo inputs to the 2-track recorder 4

- Patching to these points will replace the feed to the 2-track recorder with the patch cord signal
- EDAC connection for studio integration



**EXT GM IN L-R:** Stereo external grand master inputs

- Allows an external stereo source to be added to the grand master mix
- Feeds the grand master ACA when the **EXT** switch in the grand master select section is engaged

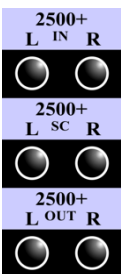

**2500+ IN L-R:** Optional 2500+C stereo bus compressor inputs

- Half-normalled to 2500+ SC L-R

**2500+ SC L-R:** Optional 2500+C stereo bus compressor side chain inputs

- Half-normalled from 2500+ IN L-R

**2500+ OUT L-R:** Optional 2500+C stereo bus compressor outputs

## 18.5.2 Surround Program Patch Points



**SURROUND SUM BUS ACCESS INPUT:** Surround summing bus access inputs

- Injected into the surround program buses
- Signals patched into the SURROUND SUM BUS ACCESS INPUT patch points will be added the bus before the surround program ACAs

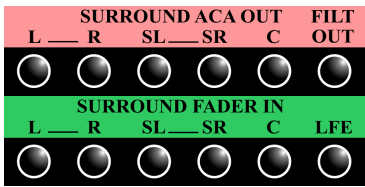

**SURROUND ACA OUT:** Surround active combining amplifier outputs

- Half-normalled to SURROUND FADER IN
- Row includes LFE filter output

**SURROUND FADER IN:** Surround master fader inputs

- Half-normalled from SURROUND ACA OUT
- Patching to these points will replace the feed to the surround master faders with the patch cord signal

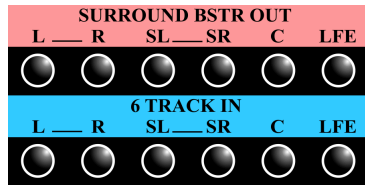

**SURROUND BSTR OUTPUTS:** Surround master fader booster outputs

- Fed from **CAL** trim pot in the master surround output modules
- Half-normalled to the 6 TRACK IN patch points

**6 TRACK IN:** Surround inputs to the 6-track recorder

- Patching to these points will replace the feed to the 6-track recorder with the patch cord signal
- EDAC connection for studio integration



**LFE FILTER IN:** Three parallel LFE filter inputs

- Not normalled

**FILT OUT (Filter Output):** Located with the LFE filter inputs

- Not normalled

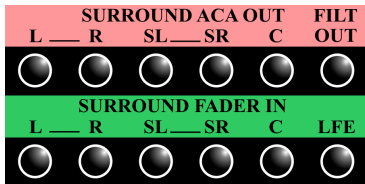

**FILT OUT (Filter Output):** Located with the surround ACA outputs

- Half-normalled to SURROUND FADER IN LFE

## 18.5.3 Lt Rt Fold Down Patch Points



**EXT. Lt Rt INPUT:** External surround inputs to the Lt Rt fold down

- Active when the Lt Rt fold down **EXT IN** switch is engaged



**Lt Rt OUT (Left-total – Right-total Output):** Stereo output of the Lt Rt fold down

- May be routed to the stereo grand master when the grand master select **LTRT** switch is engaged

## 18.5.4 Studio Monitor External Input Patch Points



**STUDIO SURROUND EXT MNTR IN (Studio Surround External Monitor Input):** External studio monitor surround inputs

- Allows an external stereo or surround source to be routed to the studio monitor EXT IN source selector
- Active only when the **EXT IN** switch in the studio monitor control is engaged

## 18.5.5 Oscillator Patch Point



**OSC OUT (Oscillator Output):** Output of the oscillator

- Active when either the oscillator **ON** switch is engaged

# 18.6 System Bay 3

## SYSTEM BAY 3

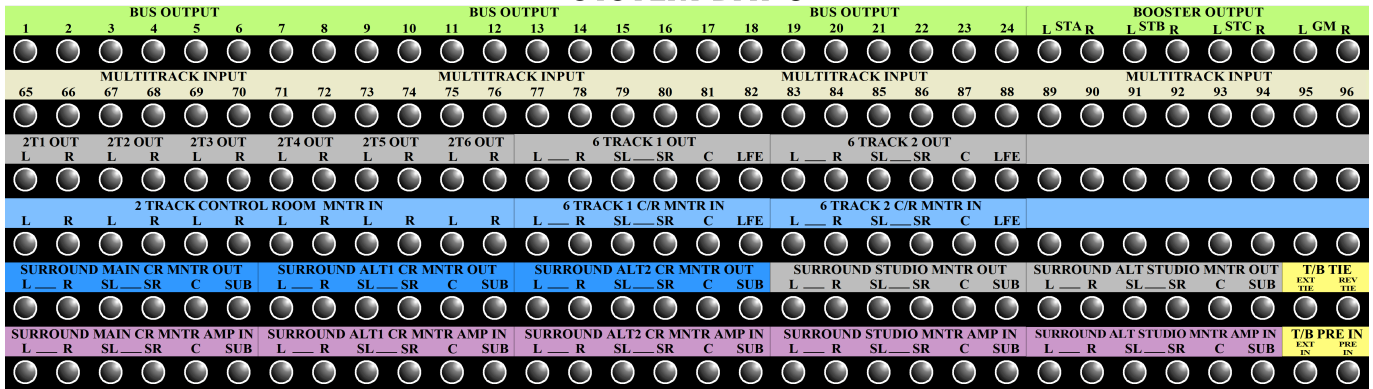

System Bay 3 contains patch points that support the following:

- Multitrack summing bus outputs
- Multitrack recorder inputs
- Stereo program bus outputs
- External recorder/playback device outputs
- Stereo and surround monitor external source inputs
- Control room monitor monitor outputs
- Control room monitor amplifier inputs
- Studio monitor outputs
- Studio amplifier inputs
- Talkback

### 18.6.1 System Bay 3 Multitrack Patch Points

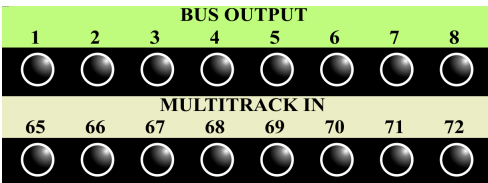

**BUS OUTPUT:** Multitrack summing bus outputs

- Half-normalled to MULTITRACK IN

**MULTITRACK IN:** Input to the multitrack recorder(s)

- Half-normalled from BUS OUTPUT
- Patching to these points will replace the feed to the multitrack recorder with the patch cord signal
- EDAC connection for studio integration

### 18.6.2 System Bay 3 Stereo Program Bus Patch Points



**STA, STB, STC, and GM Booster Output:** Program booster outputs

- Parallel with program booster outputs

## 18.6.3 Control Room Monitor Patch Points

### Playback Monitor Selector Patch Points

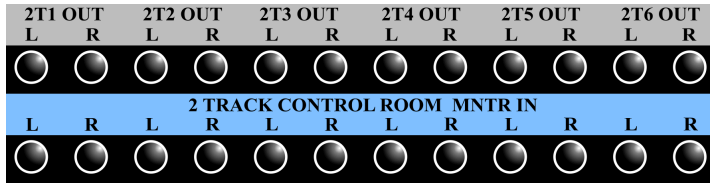

**2T 1-6 OUT (2-Track Outputs 1-6):** Stereo returns from the external 2-Track record/playback device outputs

- Half-normalled to 2 TRACK 1-6 CONTROL ROOM MNTR IN
- EDAC connection for studio integration

**2 TRACK CONTROL ROOM MNTR IN (2-Track Control Room Monitor Inputs):** Feeds the control room monitor stereo playback source selectors

- Feeds the 2T1, 2T2, 2T3, 2T4, 2T5, and 2T6 playback monitor source selectors
- Half-normalled from 2T 1-6 OUT
- Patching to these points will replace the feed to the 2-track monitor selectors with the patch cord signal

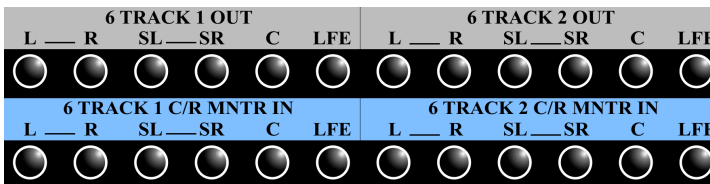

**6 TRACK 1-2 OUT (6-Track Outputs 1 and 2):** 5.1 surround returns from the external 6-Track record/playback device outputs

- Half-normalled to 6 TRACK 1-2 CONTROL ROOM MNTR IN
- EDAC connection for studio integration

**6 TRACK CONTROL ROOM MNTR IN (6-Track Control Room Monitor Inputs):** Feeds the control room monitor surround playback source selectors

- Feeds the 6T1 and 6T2 playback monitor source selectors
- Half-normalled from 6 TRACK 1-2 OUT
- Patching to these points will replace the feed to the 6-track monitor selectors with the patch cord signal

### Control Room Monitor Output and Amplifier Input Patch Points

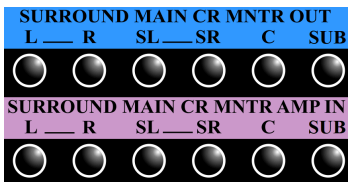

**SURROUND MAIN CR MNTR OUT (Surround Main Control Room Monitor Outputs):** Control room main monitor output feeds

- Active only when the **MAIN SPKR** (main speakers) switch is engaged
- Half-normalled to SURROUND MAIN CR MNTR AMP IN

**SURROUND MAIN CR MNTR AMP IN (Surround Main Control Room Monitor Amplifier Inputs):** Feeds the inputs of the amplifiers for the main control room monitor amplifiers

- Half-normalled from SURROUND MAIN CR MNTR OUT
- Patching to these points will replace the feed to the main monitor amps with the patch cord signal
- EDAC connection for studio integration

**CAUTION: Extreme caution should be used when patching into the SURROUND MAIN CR MNTR AMP IN patch points as these patches bypass the control room volume control.**

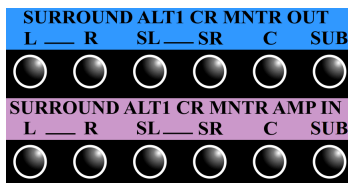

**SURROUND ALT1 CR MNTR OUT (Surround Alternate 1 Control Room Monitor Outputs):** # 1 alternate control room monitor output feeds

- Active only when the **ALT 1** (main speakers) switch is engaged
- Half-normalled to SURROUND ALT1 CR MNTR AMP IN

**SURROUND ALT1 CR MNTR AMP IN (Surround Alternate 1 Control Room Monitor Amplifier Inputs):** Feeds the inputs of the amplifiers for the # 1 alternate control room monitors

- Half-normalled from SURROUND ALT1 CR MNTR OUT
- Patching to these points will replace the feed to the main monitor amps with the patch cord signal
- EDAC connection for studio integration

**CAUTION: Extreme caution should be used when patching into the SURROUND ALT1 CR MNTR AMP IN patch points as these patches bypass the control room volume control.**

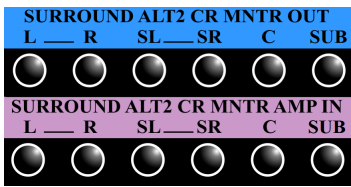

SURROUND ALT2 CR MNTR OUT (Surround Alternate 2 Control Room Monitor Outputs): #2 alternate control room monitor output feeds

- Active only when the **ALT 2** (main speakers) switch is engaged
- Half-normalled to SURROUND ALT2 CR MNTR AMP IN

SURROUND ALT2 CR MNTR AMP IN (Surround Alternate 2 Control Room Monitor Amplifier Inputs): Feeds the inputs of the amplifiers for the #2 alternate control room monitors

- Half-normalled from SURROUND ALT2 CR MNTR OUT
- Patching to these points will replace the feed to the main monitor amps with the patch cord signal
- EDAC connection for studio integration

**CAUTION: Extreme caution should be used when patching into the SURROUND ALT2 CR MNTR AMP IN patch points as these patches bypass the control room volume control.**

## 18.6.4 Studio Monitor Patch Points

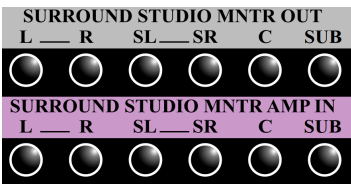

SURROUND STUDIO MNTR OUT (Surround Studio Monitor Outputs):Main studio monitor output feeds

- Half-normalled to SURROUND STUDIO MNTR AMP IN

SURROUND STUDIO MNTR AMP IN (Surround Studio Monitor Amplifier Inputs): Feeds the inputs of the studio monitor amplifiers

- Half-normalled from SURROUND STUDIO MNTR OUT
- Patching to these points will replace the feed to the Studio monitor amps with the patch cord signal
- EDAC connection for studio integration

**CAUTION: Extreme caution should be used when patching into the SURROUND STUDIO MNTR AMP IN patch points as these patches bypass the control room volume control.**



SURROUND ALT STUDIO MNTR OUT (Surround Studio Monitor Outputs): Alternate studio monitor output feeds

- Half-normalled to SURROUND STUDIO MNTR AMP IN

SURROUND ALT STUDIO MNTR AMP IN (Surround Studio Monitor Amplifier Inputs): Feeds the inputs of the alternate studio monitor amplifiers

- Half-normalled from SURROUND STUDIO MNTR OUT
- Patching to these points will replace the feed to the Studio monitor amps with the patch cord signal
- EDAC connection for studio integration

**CAUTION: Extreme caution should be used when patching into the SURROUND ALT STUDIO MNTR AMP IN patch points as these patches bypass the control room volume control.**

## 18.6.5 Talkback Patch Points

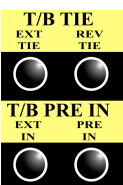

T/B TIE: Tie lines for the external and reverse talkback microphones

- Full-normalled to the T/B PRE IN patch points
- EDAC connection for studio integration

T/B PRE IN: Input to the external and reverse talkback microphone preamplifiers

- Full-normalled from the T/B TIE patch point

## **18.7 Custom User Patch Bay**

A customer patch bay for additional studio equipment that is not supported by the console patch bays, may be ordered at the time of console specification or otherwise installed by the studio owner(s).

# 19.0 Final Touch Automation®

Vison+ consoles are equipped with API's *Final Touch Automation*® system that provides the following functions:

- Centralized control of channel settings and output routing
- Creation and control of fader and switch automation
- Control group creation and management
- Snapshot creation and management
- DAW control
- File management (projects, songs, mixes, snapshots)
- Moving fader demos
- Moving fader calibration
- Firmware updates

The 940L control module (ACM) is a dual-screen version of *Final Touch Automation*® created especially to support *Vision+* consoles. It is located in the options bucket

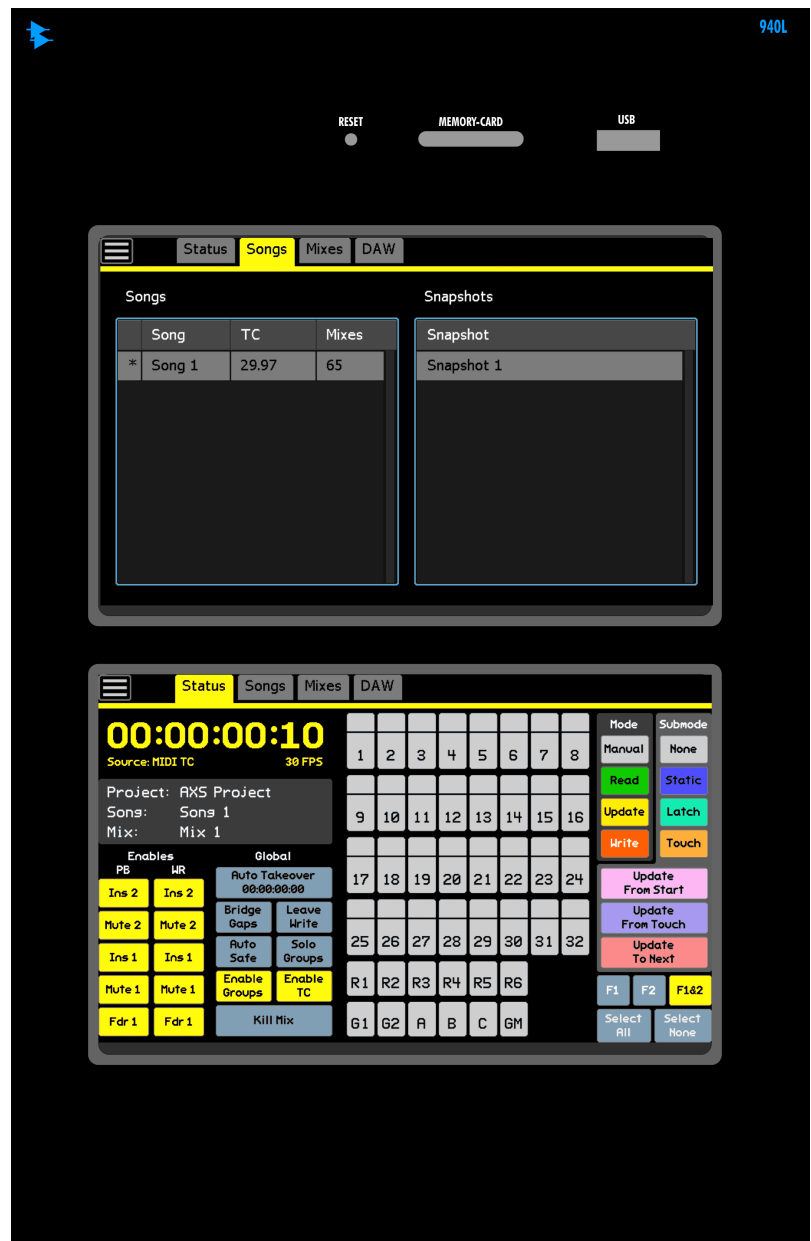

Refer to the *Final Touch Automation*® manual for more information and operational details.  
[https://www.apiaudio.com/docs/manuals/Final-Touch-Automation\\_user\\_2023-11-01.pdf](https://www.apiaudio.com/docs/manuals/Final-Touch-Automation_user_2023-11-01.pdf)

# 19.1 1068L Routing/Snapshot Control

In addition to being controlled directly from the console controls, the positions of several switches on the 1068L V3 input module may be set, stored, and recalled using the routing and snapshot systems in the *Final Touch Automation*® system.

## 1068L V3 Routing/Snapshot Controls:

The positions of the following switches may be set, stored, and recalled using the routing or snapshot systems:

### Channel:

- **EQ TO FDR2** (EQ to Fader 2)
- **DYN TO FDR1** (Dynamics to Fader 1)
- **ALT LINE** (alternate multitrack output)
- **Pan to 24** (Odd/even panning to multitrack summing buses)
- **9/10 to 1-8** (Aux 9/10 to multitrack summing buses 1-8)
- **F2 to 24** (Fader 2 to multitrack summing buses)
- **DIR FDR2** (Fader 2 to direct output)

### Fader 1:

- Fader position (snapshot only)
- 0dB bypass (long-press **Ø**)
- Solo **SAFE**
- **Ø** (polarity inverter)
- **FILT** (high-pass filter)
- **STA, STB, STC, 5.1** (program bus assignment)
- **PAN** (stereo pan-pot engage)
- **LCR** (Left, Center, Right front surround panning)
- **MIC** (MIC PATH input)
- **2=1** (Fader 2 follows Fader 1 position)

### Fader 2:

- Fader position (snapshot only)
- 0dB bypass (long-press **Ø**)
- Solo **SAFE**
- **Ø** (polarity inverter)
- **FILT** (high-pass filter)
- **STA, STB, STC, 5.1** (program bus assignment)
- **PAN** (stereo pan-pot engage)
- **LCR** (Left, Center, Right front surround panning)
- **LINE** (LINE PATH input)
- **FDR1** (Fader 2 input feed from Fader 1 output)

### Auxiliary Send Routing:

The following auxiliary send and global routing options may be set, stored, and recalled using the routing or snapshot systems:

- Auxiliary Send 1 **ON/off**
- Auxiliary Send 2 **ON/off**
- Send 1/2 -> PRE
- Send 1/2 -> FDR 2
- Auxiliary Send 3 **ON/off**

- Auxiliary Send 4 **ON**/off
- Send 3/4 -> PRE
- Send 3/4 -> FDR 2
- Auxiliary Send 5 **ON**/off
- Auxiliary Send 6 **ON**/off
- Send 5/6 -> PRE
- Send 5/6 -> FDR 2
- Auxiliary Send 7/8 **ON**/off
- Auxiliary Send 9/10 **ON**/off
- Send 7/8 and 9/10 -> PRE
- Send 7/8 and 9/10 -> FDR 2
- 9/10 to Bus 1-8

*NOTE: Auxiliary sends 9/10 follow the same routing as auxiliary sends 7/8.*

#### Multitrack Bus Assignments:

- 1-24

Refer to sections 18.0 Snapshots and 21.2 Vision Routing and Snapshots in the *Final Touch Automation*® manual for more information about routing, snapshots, and operational details.

[https://www.apiaudio.com/docs/manuals/Final-Touch-Automation\\_user\\_2023-11-01.pdf](https://www.apiaudio.com/docs/manuals/Final-Touch-Automation_user_2023-11-01.pdf)

## 19.2 Automated Controls

In addition to being controlled from the console control surface, the positions of several 1068L V3 input module controls may be automated using the *Final Touch Automation*® system.

The positions of the following 1068L may be automated using the automation system:

- **EQ BYP** (EQ bypass)
- Fader 1 **INS** (insert)
- Fader 2 **INS** (insert)
- Fader 1 (on 1044L module)
- Fader 1 **MUTE**
- Fader 2
- Fader 2 **MUTE**
- Auxiliary Send 1 **ON**/off
- Auxiliary Send 2 **ON**/off
- Auxiliary Send 3 **ON**/off
- Auxiliary Send 4 **ON**/off
- Auxiliary Send 5 **ON**/off
- Auxiliary Send 6 **ON**/off
- Auxiliary Send 7/8 **ON**/off
- Auxiliary Send 9/10 **ON**/off

Refer to the *Final Touch Automation*® manual for more information and operational details.

[https://www.apiaudio.com/docs/manuals/Final-Touch-Automation\\_user\\_2023-11-01.pdf](https://www.apiaudio.com/docs/manuals/Final-Touch-Automation_user_2023-11-01.pdf)

# Appendix

- A1 1068L V2 Input Module**
- A2 Front-End Signal Flow**
- A3 Channel Block Diagram**
- A4 Monitor Block Diagram**
- A5 212L Microphone Preamp Specifications**
- A6 212L Microphone Preamp Recall Sheet**
- A7 205L Direct Input Specifications**
- A8 205L Direct Input Recall Sheet**
- A9 215L Sweep Filter Specifications**
- A10 215L Sweep Filter Recall Sheet**
- A11 225L Compressor/Limiter Specifications**
- A12 225L Compressor/Limiter Recall Sheet**
- A13 235L Gate/Expander Specifications**
- A14 235L Gate/Expander Recall Sheet**
- A15 550A EQ Specifications**
- A16 550A EQ Recall Sheet**
- A17 550L EQ Specifications**
- A18 550L EQ Recall Sheet**
- A19 560L EQ Specifications**
- A20 560L EQ Recall Sheet**
- A21 2500+C Stereo Bus Compressor Specifications**
- A22 2500+C Stereo Bus Compressor Recall Sheet**
- A23 API Limited Warranty and Service**

# A1 1068L V2 Input Module

As mentioned earlier, the 1068L input module is the heart of the channel-strip. As the Vision console has evolved over time, three different versions of the 1068L input module have been produced: the original 1068L (V1), the V2 version, and the most recent V3 version with enhanced features.

*NOTE: This chapter directly addresses the 1068L V2 Input Module. The V3 1068L module is discussed above.*

1068L V2 is the second version of the Vision input module and is designed to support modern audio production as well as more traditional workflows. It replicates the controls, functionality, and signal flow of the original 1068L modules, but with new switches and an updated auxiliary send section.

As with all 1068L version, the 1068L V2 provides two fully-featured audio paths for multitrack recording (one for routing microphones to a multitrack and one for mixing the multitrack return) and/or two complete audio paths with automation and stereo/surround panning for mixing. A choice of inputs, a comprehensive set of channel patch points, and extensive output options combine with the other channel features to provide the flexibility needed to accomplish a host of audio production applications.

The 1068L V2 input module is designed to integrate with API's *Final Touch Automation*® system for easy project management, snapshots, and moving fader/switch automation. *Final Touch Automation*® includes channel routing/settings assignment function that can be used to setup, store, and recall snapshots of input/output assignments, fader positions, switch settings, auxiliary send routing, and global features for one or more channels. *Final Touch Automation*® also provides a comprehensive mixing automation system that records and playback moves made to both channel faders, mutes, inserts, as well as the EQ bypass, and auxiliary send on/off switches.

Refer to the *Final Touch Automation*® manual for more information and operational details.

[https://www.apiaudio.com/docs/manuals/Final-Touch-Automation\\_user\\_2023-11-01.pdf](https://www.apiaudio.com/docs/manuals/Final-Touch-Automation_user_2023-11-01.pdf)

The illustration on the next page shows the 1068L V2 input module with a brief description of each control. This serves as a quick reference guide. A more detailed description of each control will follow.

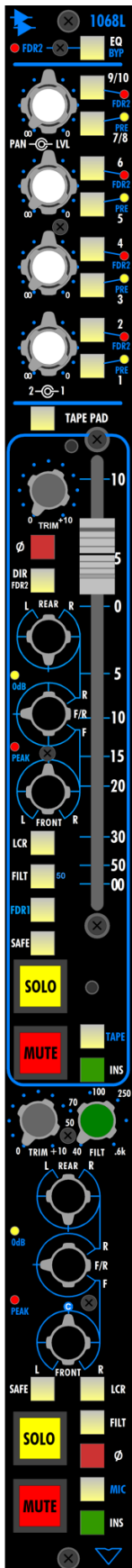

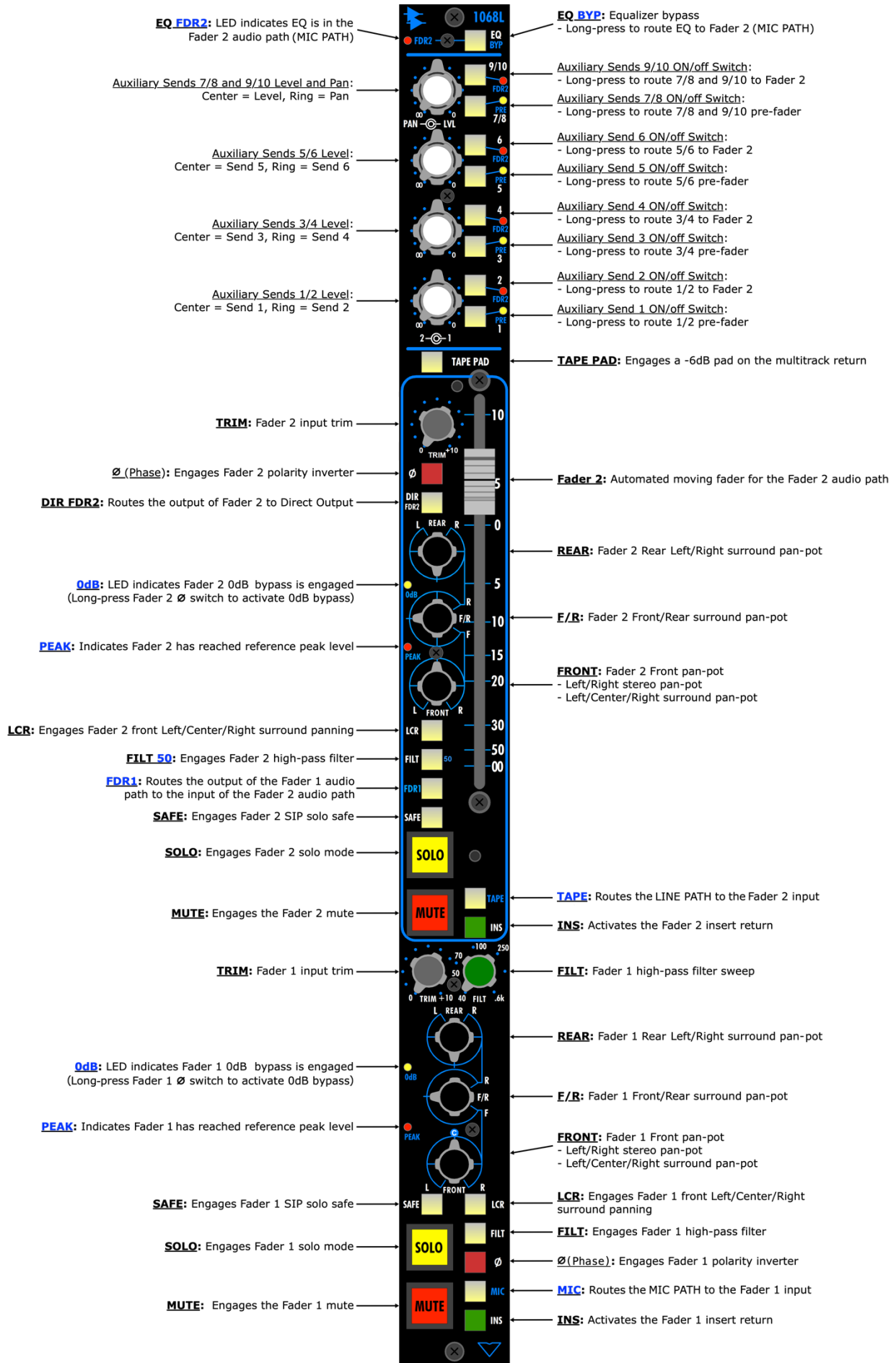

# A1.1 1068L V2 Input Module Controls

In this section, the controls on the 1068L V2 input module will be discussed in detail.

## A1.1.1 Equalizer Routing

The EQ module installed in the 500L EQ slot is assigned to the Fader 1 audio path by default.

The EQ module installed in the 500L EQ slot can be reassigned to the Fader 2 path and/or bypassed completely using the **EQ BYP** switch.

In order for the EQ to be heard, the following conditions must be met:

- The EQ be assigned to the desired path
- The **EQ** or **IN** switch on the 500L equalizer itself must be engaged (ON)
- The **EQ BYP** switch must not be engaged

The **EQ BYP** (bypass) switch is a dual-function switch that functions as follows:

- **EQ BYP**: Removes the 500L EQ slot from the assigned audio path
  - Hard-wire bypass
  - Press and release to activate
  - Automation control
  - Switch illuminates when engaged
- **EQ FDR2**: Moves the EQ (and its patch points) from the LINE PATH (Fader 1) to the MIC PATH (Fader 2)
  - Long-press (press and hold) to activate
  - Routing/Snapshot control
  - Red LED illuminates when engaged

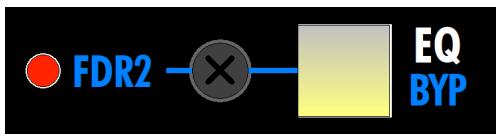

Assigning the EQ to Fader 2 can be set on individual channels on the 1068L module or on multiple channels using the routing system. EQ routing can also be stored and recalled using snapshots.

Refer to sections 18.0 Snapshots and 21.2 Vision Routing and Snapshots in the *Final Touch Automation*® manual for more information about routing, snapshots, and operational details. [https://www.apiaudio.com/docs/manuals/Final-Touch-Automation\\_user\\_2023-11-01.pdf](https://www.apiaudio.com/docs/manuals/Final-Touch-Automation_user_2023-11-01.pdf)

## A1.1.2 Auxiliary Sends

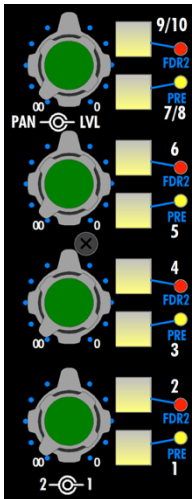

The *Vision+* console provides a powerful auxiliary send system that provides a comprehensive set of options for cue sends (headphone feeds), effects sends, and other auxiliary mix applications.

The 1068L V2 is equipped with a total of ten (10) auxiliary sends:

- Six (6) mono sends (1-6)
- Two (2) stereo sends (7/8 and 9/10)

Auxiliary sends 1-6 are primarily used as effects sends during recording and mixing, but may be also be used as cue sends during recording if needed.

Auxiliary sends 7/8 and 9/10 are intended for use as cue sends during recording and as stereo effects sends during mixing.

All auxiliary sends are routed post-fader from the Fader 1 audio path by default. All sends can be routed pre-fader and/or from Fader 2 in pairs (1-2, 3-4, etc.). Routing for sends 7/8 and 9/10 is always the same.

Refer to section 4.0 Output Assignment in this manual and/or sections 18.0 Snapshots and 21.2 Vision Routing and Snapshots in the *Final Touch Automation*® manual for more information about routing, snapshots, and operational details.

[https://www.apiaudio.com/docs/manuals/Final-Touch-Automation\\_user\\_2023-11-01.pdf](https://www.apiaudio.com/docs/manuals/Final-Touch-Automation_user_2023-11-01.pdf)

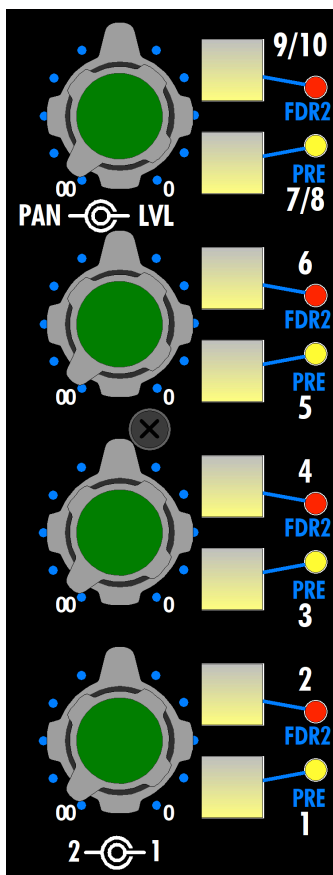

Auxiliary sends are organized in pairs and assigned in four groups:

- Mono 1 and 2
- Mono 3 and 4
- Mono 5 and 6
- Stereo 7/8 and 9/10

Each group of auxiliary sends may be sourced as follows:

- Fader 1 or Fader 2 audio path
- Pre or post the assigned fader

Routing assignments may be made:

- Locally on the 1068L input module
- Routing/Snapshot control

The status of each group of auxiliary sends is indicated as follows:

- **ON**/off switch illuminates when the send is ON
- Red **FDR2** LED illuminates when the pair is fed from Fader 2
- Yellow **PRE** LED illuminates when the pair is fed pre-fader

*IMPORTANT NOTE: Stereo auxiliary sends 7/8 and 9/10 may be used at the same time, but will have the same routing, level, and panning.*

Each auxiliary send in each group, mono or stereo, is equipped with a dual-function switch, labeled with its send number (1-6, 7/8, or 9/10). This send switch functions as follows:

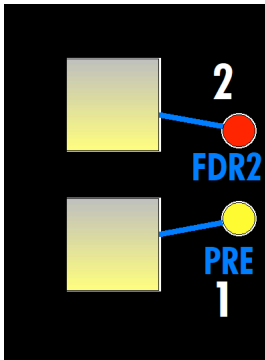

- **Send ON/off:** Activates the send
  - Press and release to activate
  - Automation control
  - Switch illuminates when engaged
- **FDR2:** Routes the pair of sends from the Fader 2 audio path
  - Long-press (press and hold) the **ON/off** switch for the higher, even-numbered send to activate
  - Routing/Snapshot control
  - Red LED illuminates when engaged
- **PRE:** Routes the pair of sends pre-fader from the assigned path
  - Long-press (press and hold) the **ON/off** switch for the lower send to activate
  - Routing/Snapshot control
  - Red yellow illuminates when engaged

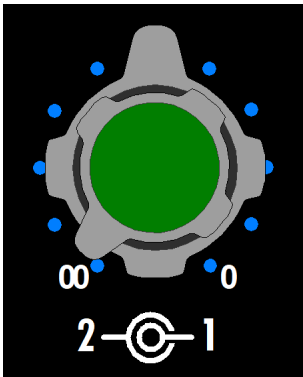

A dual-concentric pot is provided to control the levels for each pair mono auxiliary sends: 1-2, 3-4, 5-6. The inner knob controls the level of the lower odd-numbered send and the ring controls the level of the higher even-numbered send.

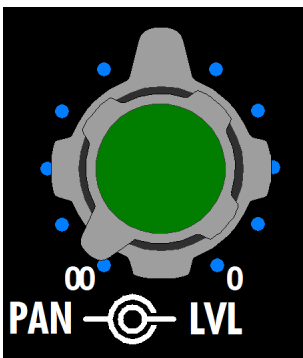

A single dual-concentric pot is provided to control the level and panning for the pair of stereo auxiliary sends: 7/8 and 9/10. The inner knob controls the level and the ring controls the panning for both stereo sends.

### Aux Pre Mute Function

The pre-fader auxiliary sends can be made to mute when the channel **MUTE** switch is engaged. This is accomplished by engaging the **AUX PRE MUTE** switch in the SOLO area of the center section.



**AUX PRE MUTE:** Links the 1068L **MUTE** switches with the **ON/off** switch on pre-fader auxiliary sends

- All pre-fader auxiliary sends mute when a channel **MUTE** switch is engaged
- Illuminates in yellow when engaged

## A1.1.3 Tape Pad

A -6dB pad can be inserted on the multitrack return line input. This is located before the input selection switch (**MIC** or **TAPE**) for both audio paths and is applied only to the TAPE side of the input.



**TAPE PAD:** Inserts a -6dB pad between the MULTITRACK OUT and the tape (line) input to both Fader 1 and Fader 2 audio paths.

- Routing/Snapshot control
- Illuminates when engaged

Engaging the -6dB **TAPE PAD** switch will reduce distortion and increase headroom in the audio path when the level from the multitrack recorder return is hot enough to overload the TAPE input. The -6dB Tape Pad can also be engaged on multiple channels in the global controls in the routing window in the *Final Touch Automation*<sup>®</sup> system. The **TAPE PAD** switch settings can also be stored and recalled using snapshots.

Refer to sections 18.0 Snapshots and 21.2 Vision Routing and Snapshots in the *Final Touch Automation*<sup>®</sup> manual for more information about routing, snapshots, and operational details. [https://www.apiaudio.com/docs/manuals/Final-Touch-Automation\\_user\\_2023-11-01.pdf](https://www.apiaudio.com/docs/manuals/Final-Touch-Automation_user_2023-11-01.pdf)

## A1.1.4 Fader 2 Controls

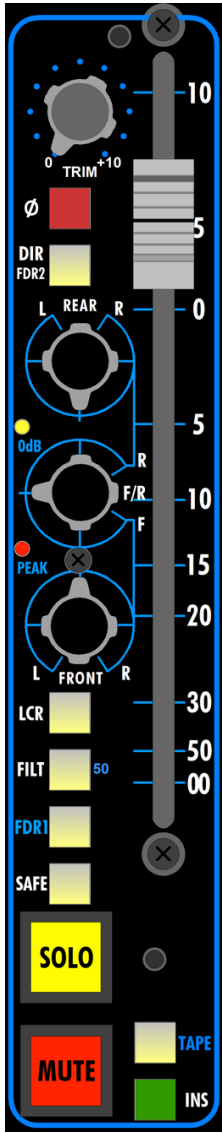

The 1068L V2 Fader 2 audio path (also referred to as “mic path”) is a complete audio channel designed to serve the following functions:

- Routing microphone and instrument inputs to a multitrack recorder
- Multitrack returns for additional inputs during mixdown
- Retuning effects, virtual tracks, and other sources during mixdown
- LFE send during mixdown
- Additional aux send during mixdown
- Creating stems and bouncing tracks
- Any other operation that needs a fully-featured audio path

Accordingly, the Fader 2 audio path is equipped with the following features (in the order they appear in the signal flow):

- MIC PATH (default) or LINE PATH (tape) input selection
- Input trim pot (0 to +10dB)
- Fader 1 output as an alternate input option
- Lower 200L slot processing (DYN)
- Assignable EQ
- Insert send with automatable return
- Phase reverse (polarity inverter)
- Peak indicator
- Touch sensitive, full-sized 100mm, motorized moving fader (1044L)
- 0dB fader bypass function
- 50Hz high-pass Filter
- Automatable mute
- Full solo functions with solo safe
- Assignable to the direct output
- Program and multitrack bus output routing
- Stereo/surround panning
- Auxiliary send routing
- Access to channel meter (depending on master meter selection)

In the section that follows, the controls for the Fader 2 audio path are described in detail in the order they appear in the signal flow.

The 1068L V2 Fader 2 audio path supports two audio inputs, both of which are accessible in the channel patch bay.

- **MIC:** The output of the MIC PATH (preamp, lower 200L slot, and Fader 2 insert)
  - MIC PREAMP OUT half-normalled to MIC PATH INPUT patch points
- **TAPE:** The output of the LINE PATH (line in, 500L EQ, and Fader 1 insert)
  - MULTITRACK OUT half-normalled to LINE PATH INPUT (tape) patch points

MIC is the default input for Fader 2. The TAPE input can be selected using the **TAPE** switch.



**TAPE:** Routes the LINE PATH (multitrack out) to the Fader 2 input

- Replaces the MIC PATH as the Fader 2 input
- Routing/Snapshot control
- Illuminates when engaged

*NOTE: The input for Fader 2 may be set to TAPE on all channels by engaging the **FDR 2 TAPE** master input selector switch (INPUT SELECT) in the center section.*

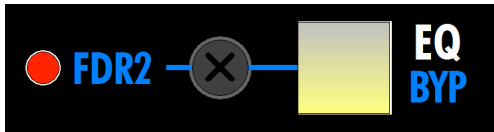

**EQ BYP** (bypass) is a dual-function switch that functions as follows:

- **EQ BYP**: Removes the 500L EQ slot from the assigned audio path
  - Hard-wire bypass
  - Press and release to activate
  - Automation control
  - Switch illuminates when engaged
- **EQ FDR2**: Moves the EQ (and its patch points) from the LINE PATH (Fader 1) to the MIC PATH (Fader 2)
  - Long-press (press and hold) to activate
  - Routing/Snapshot control
  - Red LED illuminates when engaged



**INS** (Insert): Activates the Fader 2 insert return

- Insert send is fed pre-fader from the output of the lower 200L slot in the PREAMP INPUT path
- Insert send feeds the FADER 2 INSERT SEND patch point and is always active
- Insert return is located before the 1068L Fader 2 input in the PREAMP INPUT path
- Insert return is fed from the FADER 2 INSERT RETURN patch point
- Insert return is active only when the **INS** switch is engaged
- Automation control
- Illuminates in green when engaged



**Ø** (Phase Reverse): Inserts a polarity inverter in the Fader 2 audio path

- Located at 1068L Fader 2 input
- Routing/Snapshot control
- Illuminates in red when engaged

Long-pressing (press and hold) the **Ø** switch will activate the 0dB fader bypass in the Fader 2 audio path.



**FDR1** (Fader 1 Output): Routes the output of Fader 1 audio path to the Fader 2 audio path input

- Fader 1 output is routed to the Fader 2 audio path input, post the polarity inverter (phase reverse) and before the fader
- Useful for creating a LFE feed or an additional auxiliary send using the Fader 2 audio path
- Useful for creating stems and bouncing tracks
- Routing/Snapshot control
- Illuminates when engaged

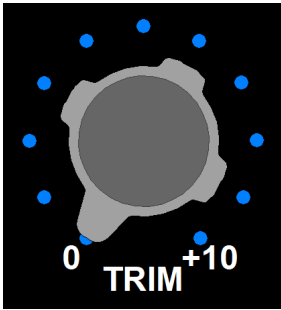

**TRIM:** Sets the amount of pre-fader level trim (boost)

- 0 to +10dB of gain
- Located Pre-fader, so the added gain is reflected in all post-fader stages (Aux sends, solos, bus assignments, and direct output).



**PEAK:** A red LED illuminates when the preset peak reference level is reached in the Fader 2 audio path

- Peak level is selected by the **PEAK REFERENCE** control in the center section

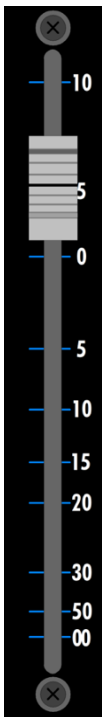

**FADER 2:** Controls the output level of the Fader 2 audio path

- 0dB is unity gain
- Touch sensitive, full-sized 100mm, motorized fader
- Automation control
- 0dB fader bypass (via DAW control)



**0dB:** Illuminates in yellow when the Fader 2 0dB bypass is engaged

- Long-press (press and hold) the  $\emptyset$  switch to activate



**FILT (Filter):** Activates the Fader 2 high-pass filter

- -3 dB at 50Hz
- 12dB/octave slope
- Located post-fader, pre-mute
- Routing/snapshot control
- Illuminates when engaged



**MUTE:** Cuts the Fader 2 audio output

- **MUTE** switch is the on/off switch for the Fader 2 audio path
- Automation control
- Illuminates in red when engaged



**DIR FDR2 (Direct Output Fader 2):** Routes the output of Fader 2 audio path to the direct output

- Direct output is fed POST the MUTE switch
- Direct output is fed from Fader 1 by default

- Feeds the DIRECT OUTPUT patch point, which is half-normalled to the MULTITRACK INPUT patch point
- Routing/snapshot control
- Illuminates when engaged

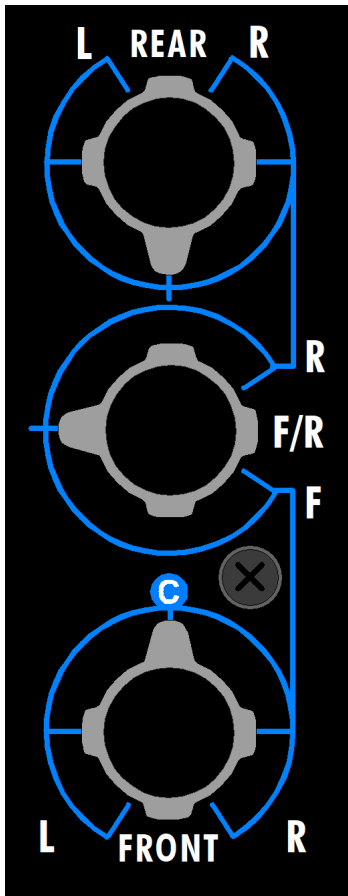

### Fader 2 Pan-Pots

#### **REAR (Left-Right)**: Rear left-right pan-pot

- Sets the rear left-right pan position to the surround program buses
- Center detent

#### **F/R (Front/Rear)**: Front-Rear pan-pot

- Sets the front/rear pan position to the surround program buses
- Center detent

#### **FRONT (Left-Right)**: Stereo left-right and front surround left-right pan-pot

- Dual independent pan-pots on one shaft
- One sets the left-right panning to the stereo program buses
- One sets the front panning to the FRONT surround program buses
- Left-right panning is selected by default for surround panning
- Front left-center-right panning can be enabled for surround mixing by engaging the **LCR** switch
- Center detent

*IMPORTANT NOTE: The **FRONT** pan-pot is two pan-pots ganged together to a single knob. When assigned, one pan-pot feeds the left-right stereo program buses A, B, and C, and the other feeds the front left-right or left-center-right surround program buses. Because of this innovative design, the **F/R** pan-pot has no affect on the feed to the stereo program buses, allowing simultaneous stereo and surround mixing without using the Lt Rt fold down matrix.*

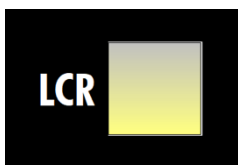

#### **LCR (Left Center Right)**: Activates left-center-right panning for Fader 2

- Activates feed to center program bus from the **FRONT** pan-pot
- Audio panned front and center **C** is fed to the center surround program bus when engaged
- Audio panned front and center **C** is not fed to the surround left and surround right program buses
- Stereo left-right front surround panning is selected by default

- Routing/snapshot control
- Illuminates when engaged



**SOLO:** Activates the selected solo function for Fader 2

- The following solo functions may be selected in the center section:
  - Pre-fader Listen (PFL): Non-destructive, mono, solo bus
  - After Fader Listen (AFL): Non-destructive, stereo, solo bus
  - Solo-In-Place (SIP): Destructive, panned, post-fader, program bus
- Illuminates in yellow when engaged

*NOTE: AFL is the default solo mode.*



**SAFE:** Activates the solo safe mode for Fader 2

- Inhibits Fader 2 muting when Solo-In-Place is active and another channel is soloed
- Routing/snapshot control
- Illuminates when engaged

## A1.1.5 Fader 1 Controls

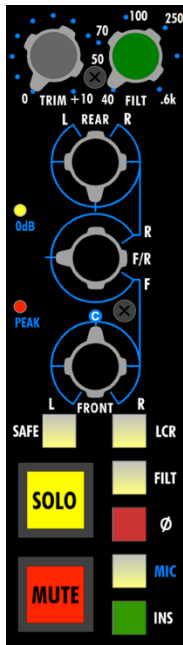

Coupled with an automated fader module, the 1068L V2 Fader 1 audio path (also referred to as “line path”) is a complete audio channel designed to serve the following functions:

- Multitrack returns during tracking and mixdown
- Retuning effects, virtual tracks, and other sources during mixdown
- Routing microphone and instrument inputs to a live stereo and/or surround mix
- Routing microphone and instrument inputs to a multitrack recorder
- Creating stems and bouncing tracks
- Any other operation that needs a fully-featured audio path

Accordingly, the Fader 1 audio path is equipped with the following features (in the order they appear in the signal flow):

- LINE PATH (tape) (default) or MIC PATH input selection
- Input trim pot (0 to +10dB)
- Assignable EQ
- Insert send with automatable return
- Phase reverse (polarity inverter)
- Full-sized 100mm automated moving fader
- Peak Indicator
- High-pass sweep filter
- Touch sensitive, full-sized 100mm, motorized moving fader (1044L)
- 0dB fader bypass function
- Direct output
- Stereo/surround panning
- Program and multitrack bus output routing
- Auxiliary send routing
- Full solo functions with solo safe
- Access to channel meter (depending on master meter selection)

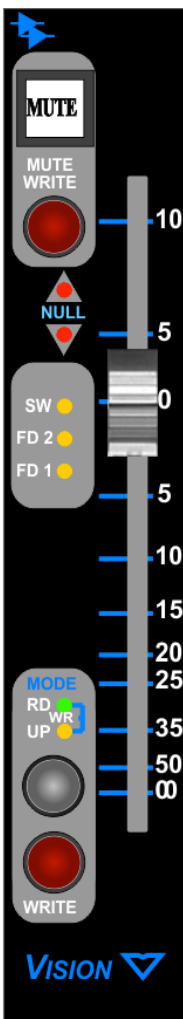

In the section that follows, the controls for the LINE PATH / Fader 1 audio paths are described in detail in the order they appear in the signal flow.

The 1068L V2 Fader 1 audio path supports two audio inputs, both of which are accessible in the channel patch bay.

- **MIC**: The output of the MIC PATH (preamp, lower 200L slot, and Fader 2 insert)
  - MIC PREAMP OUT is half-normalled to the MIC PATH INPUT patch points
- **TAPE**: The output of the LINE PATH (line in, 500L EQ, and Fader 1 insert)
  - MULTITRACK OUT is half-normalled to the LINE PATH INPUT patch points

LINE is the default input for Fader 1. The MIC input for Fader 1 can be selected using the **MIC** switch.



**MIC**: Routes the MIC PATH (PREAMP OUT) to the Fader 1 input

- Replaces TAPE (LINE PATH) as the Fader 1 input
- Routing/Snapshot control
- Illuminates when engaged

*NOTE: The input for Fader 1 may be set to MIC on all channels by engaging the **FDR1 MIC** master input selector switch (INPUT SELECT) in the center section.*

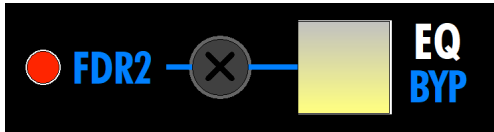

The **EQ BYP** (bypass) switch is a dual-function switch that functions as follows:

- **EQ BYP**: Removes the 500L EQ slot from the assigned audio path
  - Hard-wire bypass
  - Press and release to activate
  - Automation control
  - Switch illuminates when engaged
- **EQ FDR2**: Moves the EQ (and its patch points) from the LINE PATH (Fader 1) to the MIC PATH (Fader 2)
  - Long-press (press and hold) to activate
  - Routing/Snapshot control
  - Red LED illuminates when engaged



**INS** (Insert): Activates the Fader 1 insert return

- Insert send is fed pre-fader from the output of the 500L EQ slot in the LINE INPUT path
- Insert send feeds the FADER 1 INSERT SEND patch point and is always active
- Insert return is located before the 1068L Fader 1 input in the LINE INPUT path
- Insert return is fed from the FADER 1 INSERT RETURN patch point
- Insert return is active only when the **INS** switch is engaged
- Automation control
- Illuminates in green when engaged



**Ø** (Phase Reverse): Inserts a polarity inverter in the Fader 1 audio path

- Located at 1068L Fader 1 input
- Routing/Snapshot control
- Illuminates in red when engaged

Long-pressing (press and hold) the **Ø** switch will activate the 0dB fader bypass in the Fader 2 audio path.



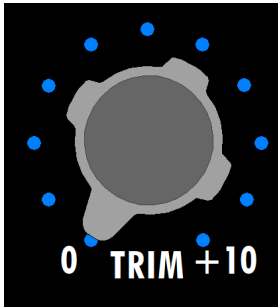

**TRIM:** Sets the amount of pre-fader level trim (boost)

- 0 to +10dB of gain
- Located Pre-fader, so the added gain is reflected in all post-fader stages (aux sends, solos, bus assignments and direct output)



**PEAK:** A red LED illuminates when the preset peak reference level is reached in the Fader 1 audio path

- Peak level is selected by the **PEAK REFERENCE** control in the center section

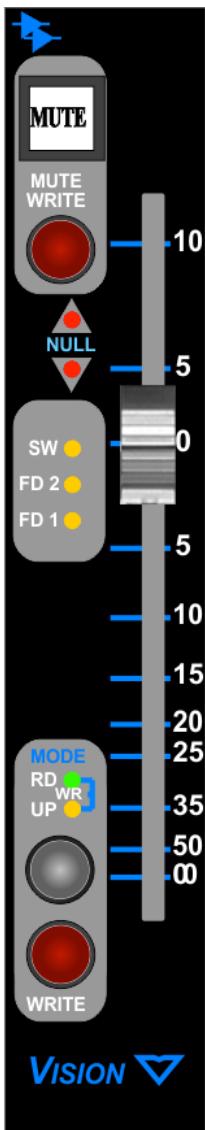

**FADER 1:** Controls the output level of the Fader 1 audio path

- 0dB is unity gain
- Touch sensitive, full-sized 100mm, motorized fader
- Automation control
- 0dB fader bypass (long-press the Ø switch to activate)



**0dB:** Illuminates in yellow when the Fader 1 0dB bypass is engaged

- Long-press (press and hold) the Ø switch to activate



Automation Switches and Indicators



**FILT (Filter) Switch:** Activates the Fader 1 high-pass sweep filter

- 12dB/octave slope
- Located post-fader, pre-mute
- Routing/Snapshot control
- Illuminates when engaged

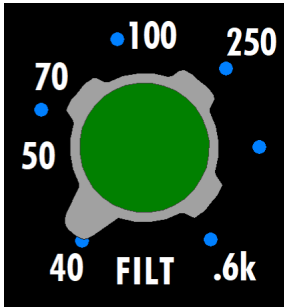

**FILT** (Filter) Sweep: Sets the Fader 1 high-pass filter frequency

- 40Hz to 600Hz sweep
- 12dB/octave slope
- Located Post-Fader
- Active when **FILT** switch is engaged



**MUTE**: Cuts the Fader 1 audio output

- **MUTE** switch is the on/off switch for the Fader 1 audio path
- Automation control
- Illuminates in red when engaged

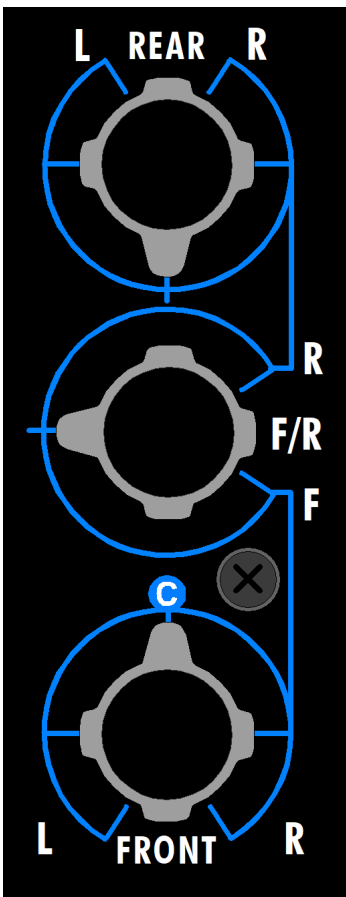

### Fader 1 Pan-Pots

**REAR (Left-Right)**: Rear left-right pan-pot

- Sets the rear left-right pan position to the surround program buses
- Center detent

**F/R (Front/Rear)**: Front-Rear pan-pot

- Sets the front/rear pan position to the surround program buses
- Center detent

**FRONT (Left-Right)**: Stereo left-right and front surround left-right pan-pot

- Dual independent pan-pots on one shaft
- One sets the left-right panning to the stereo program buses
- One sets the front panning to the FRONT surround program buses
- Left-right panning is selected by default for surround panning
- Front left-center-right panning can be enabled for surround mixing by engaging the **LCR** switch
- Center detent

**IMPORTANT NOTE:** The **FRONT** pan-pot is two pan-pots ganged together to a single knob. When assigned, one pan-pot feeds the left-right stereo program buses A, B, and C, and the other feeds the front left-right or left-center-right surround program buses. Because of this innovative design, the **F/R** pan-pot has no affect on the feed to the stereo program buses, allowing simultaneous stereo and surround mixing without using the Lt Rt fold down matrix.



**LCR (Left Center Right):** Activates left-center-right panning for Fader 1

- Activates feed to center program bus from the **FRONT** pan-pot
- Audio panned front and center **C** is fed to the center surround program bus when engaged
- Audio panned front and center **C** is not fed to the surround left and surround right program buses
- Stereo left-right front surround panning is selected by default
- Routing/Snapshot control
- Illuminates when engaged



**SAFE:** Activates the solo safe mode for Fader 1

- Inhibits Fader 1 muting when Solo-In-Place is active and another channel is soloed
- Routing/Snapshot control
- Illuminates when engaged



**SOLO:** Activates the selected solo function for Fader 1

- The following solo functions may be selected in the center section:
  - Pre-fader Listen (PFL): Non-destructive, mono, solo bus
  - After Fader Listen (AFL): Non-destructive, stereo, solo bus
  - Solo-In-Place (SIP): Destructive, panned, post-fader, program bus
- Illuminates in yellow when engaged

*NOTE: AFL is the default solo mode.*

## A1.1.6 1068L V2 Routing/Snapshot Control

In addition to being controlled directly from the console controls, the positions of several switches on the 1068L V2 input module may be set, stored, and recalled using the routing and snapshot systems in the *Final Touch Automation*® system.

### 1068L V2 Routing/Snapshot Controls:

The positions of the following switches may be set, stored, and recalled using the routing or snapshot systems:

Channel:

- **EQ TO FDR2** (EQ to Fader 2)
- **TAPE PAD** (-6dB line input pad)
- **Pan to 24** (Odd/even panning to multitrack summing buses)
- **9/10 to 1-8** (Aux 9/10 to multitrack summing buses 1-8)
- **F2 to 24** (Fader 2 to multitrack summing buses)
- **DIR FDR2** (Fader 2 to direct output)

### Fader 1:

- Fader position (snapshot only)
- Solo **SAFE**
- **Ø** (polarity inverter)
- **FILT** (high-pass filter)
- **STA, STB, STC, 5.1** (program bus assignment)
- **PAN** (stereo pan-pot engage)
- **LCR** (Left, Center, Right front surround panning)
- **MIC** (MIC PATH input)
- **2=1** (Fader 2 follows Fader 1 position)

### Fader 2:

- Fader position (snapshot only)
- Solo **SAFE**
- **Ø** (polarity inverter)
- **FILT** (high-pass filter)
- **STA, STB, STC, 5.1** (program bus assignment)
- **PAN** (stereo pan-pot engage)
- **LCR** (Left, Center, Right front surround panning)
- **LINE** (LINE PATH input)
- **FDR1** (Fader 2 input feed from Fader 1 output)

### Auxiliary Send Routing:

The following auxiliary send and global routing options may be set, stored, and recalled using the routing or snapshot systems:

- Auxiliary Send 1 **ON/off**
- Auxiliary Send 2 **ON/off**
- Send 1/2 -> PRE
- Send 1/2 -> FDR 2
- Auxiliary Send 3 **ON/off**
- Auxiliary Send 4 **ON/off**
- Send 3/4 -> PRE
- Send 3/4 -> FDR 2
- Auxiliary Send 5 **ON/off**
- Auxiliary Send 6 **ON/off**
- Send 5/6 -> PRE
- Send 5/6 -> FDR 2
- Auxiliary Send 7/8 **ON/off**
- Auxiliary Send 9/10 **ON/off**
- Send 7/8 and 9/10 -> PRE
- Send 7/8 and 9/10 -> FDR 2
- 9/10 to Bus 1-8

*NOTE: Auxiliary sends 9/10 follow the same routing as auxiliary sends 7/8.*

### Multitrack Bus Assignments:

- 1-24

Refer to sections 18.0 Snapshots and 21.2 Vision Routing and Snapshots in the *Final Touch Automation*® manual for more information about routing, snapshots, and operational details.  
[https://www.apiaudio.com/docs/manuals/Final-Touch-Automation\\_user\\_2023-11-01.pdf](https://www.apiaudio.com/docs/manuals/Final-Touch-Automation_user_2023-11-01.pdf)

## A1.1.7 1068L V2 Automation Controls

In addition to being controlled from the console control surface, the positions of several 1068L V2 input module controls may be automated using the *Final Touch Automation*® system.

The positions of the following 1068L V2 may be automated using the automation system:

- **EQ BYP** (EQ bypass)
- Fader 1 **INS** (insert)
- Fader 2 **INS** (insert)
- Fader 1 (in channel fader bay)
- Fader 1 **MUTE**
- Fader 2
- Fader 2 **MUTE**
- Auxiliary Send 1 **ON/off**
- Auxiliary Send 2 **ON/off**
- Auxiliary Send 3 **ON/off**
- Auxiliary Send 4 **ON/off**
- Auxiliary Send 5 **ON/off**
- Auxiliary Send 6 **ON/off**
- Auxiliary Send 7/8 **ON/off**
- Auxiliary Send 9/10 **ON/off**

Refer to sections 18.0 Snapshots and 21.2 Vision Routing and Snapshots in the *Final Touch Automation*® manual for more information about routing, snapshots, and operational details.  
[https://www.apiaudio.com/docs/manuals/Final-Touch-Automation\\_user\\_2023-11-01.pdf](https://www.apiaudio.com/docs/manuals/Final-Touch-Automation_user_2023-11-01.pdf)

# A1.1.8 1068L V2 Routing Page

☰
Status **Routing**
05/19/2025 23:33

Sends		Channel	EQ to F2		Tape Pad	Buses					
Clear	Clear	Clear				Clear					
9-10	7-10 F2	Pan to 24	9/10 to 1-8	F2 to 24	F2 Direct	21	22	23	24		
7-8	7-10 Pre	Fader 2	Clear	FDR1	Solo Safe	HP	17	18	19	20	
6	5/6 F2	STA	STB	STC	5.1	Line	13	14	15	16	
5	5/6 Pre	Phase		Pan to Stereo		LCR	9	10	11	12	
4	3/4 F2	Fader 1	Clear	F2=1	Solo Safe	HP	5	6	7	8	
3	3/4 Pre	STA	STB	STC	5.1	Mic	1	2	3	4	
2	1/2 F2	Phase		Pan to Stereo		LCR	Clear Routing				
1	1/2 Pre	Read Console				Undo	Redo	Clear Inserts			
						Clear Mutes					

# A2 Front-End Signal Flow

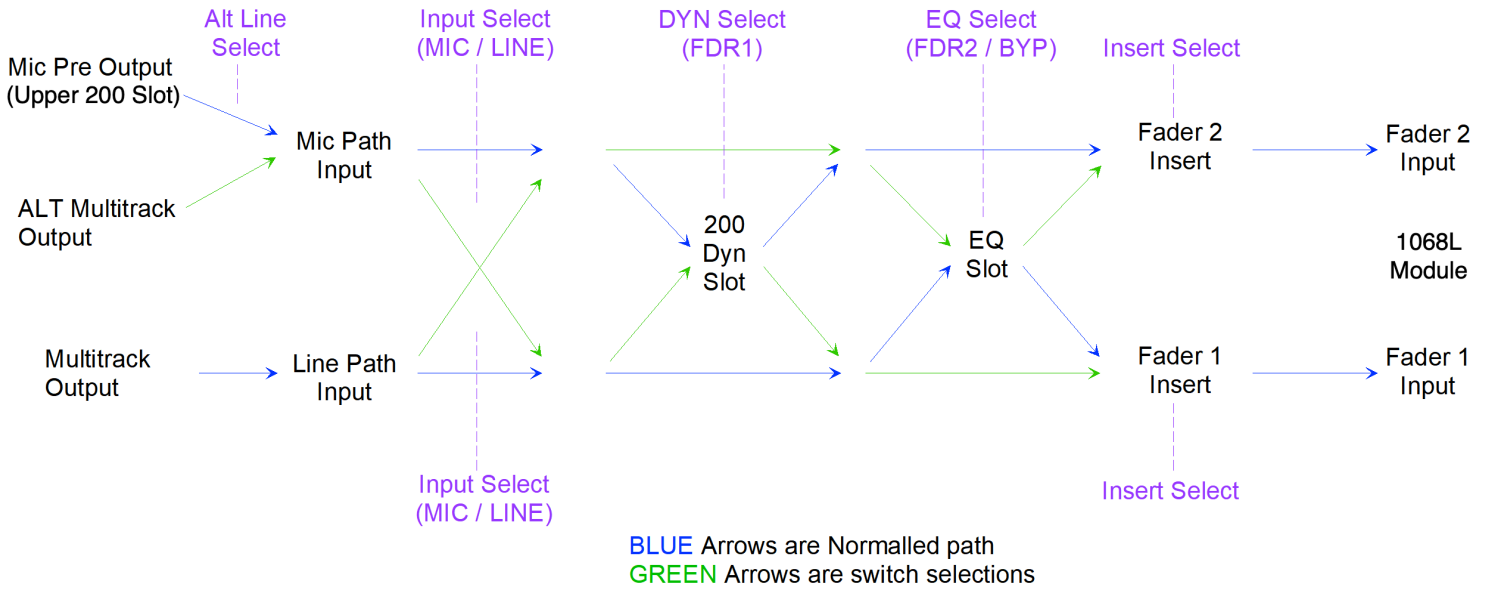

# A3 Channel Block Diagram

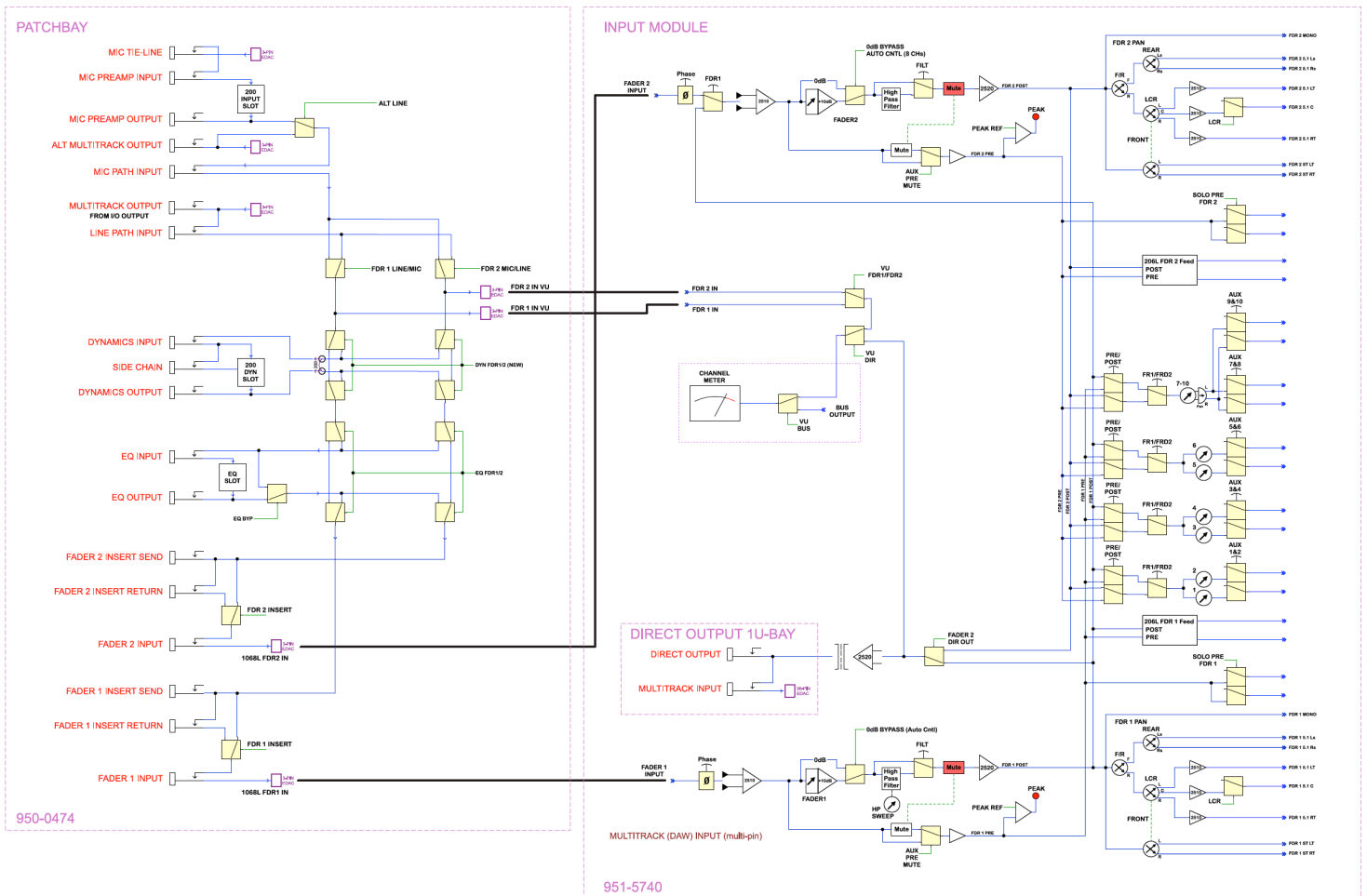

# A4 Monitor Block Diagram

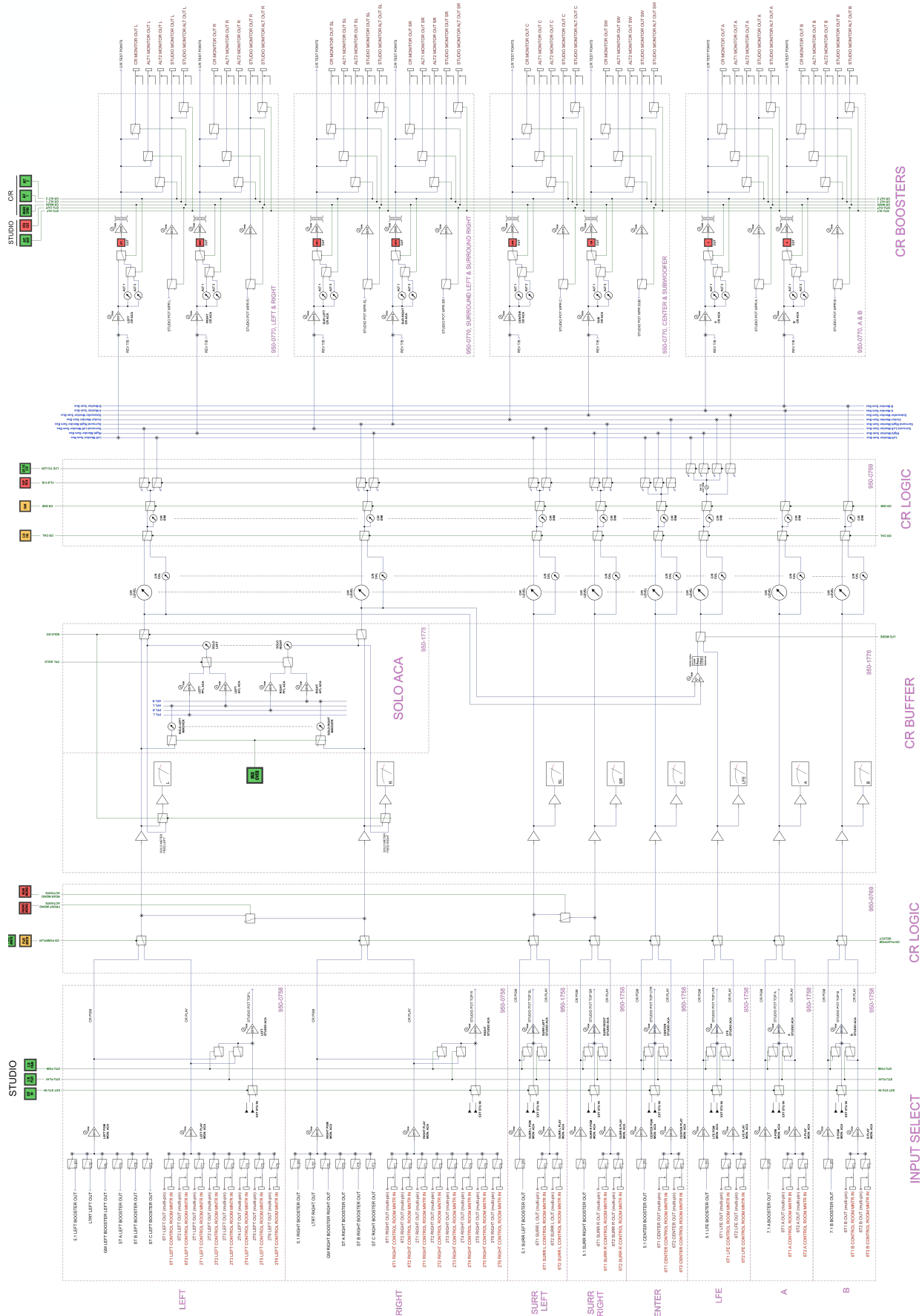

# A5 212L Microphone Preamp Specifications

**Website:** <https://apiaudio.com/product/212l-mic-pre/>

**Input Impedance:** Mic In 1500 Ohms  
**Output Impedance:** 85 Ohms, transformer coupled, balanced  
**Maximum Input Level:** +2dBu, No Pad, +18dBu with pad  
**Gain:** 55dB max  
**Pad:** 20dB, 1500/150 Ohm load  
**Clipping Level:** +28dBu  
**Frequency Response:** 0, -.3, 30Hz to 20kHz  
**Noise (Actual Measured):** -102dBu unweighted, -125dBu A-weighted  
20Hz to 20kHz  
**Distortion (THD@2kHz):** +4dB = .02%, 15dB = .01%, -15dB = .05%

# A6 212L Recall Sheet

ARTIST:  
ENGINEER:  
DATE:

NOTES:  
DRAWN BY:  
STUDIO:

CHAN#	CHAN#	CHAN#	CHAN#	CHAN#	CHAN#	CHAN#	CHAN#
TITLE	TITLE	TITLE	TITLE	TITLE	TITLE	TITLE	TITLE
NOTES	NOTES	NOTES	NOTES	NOTES	NOTES	NOTES	NOTES

CHAN#	CHAN#	CHAN#	CHAN#	CHAN#	CHAN#	CHAN#	CHAN#
TITLE	TITLE	TITLE	TITLE	TITLE	TITLE	TITLE	TITLE
NOTES	NOTES	NOTES	NOTES	NOTES	NOTES	NOTES	NOTES

# A7 205L Direct Input Specifications

<b>Website:</b>	<a href="https://apiaudio.com/product/205l-direct-input/">https://apiaudio.com/product/205l-direct-input/</a>
<b>Number of Bands:</b>	Two
<b>Filter Type:</b>	Passive shelf
<b>Frequency Centers:</b>	Low: 150Hz, High: 8kHz
<b>Input Impedance:</b>	>470 Ohms, unbalanced
<b>Output Impedance:</b>	85 Ohms, transformer coupled, balanced
<b>Nominal Levels:</b>	-40dBu to +20dBu
<b>Clipping Level:</b>	+28dBu
<b>Frequency Response:</b>	0, -.3, 30Hz to 20kHz
<b>Noise (Actual Measured):</b>	98dB below +10dBm output unweighted 20Hz to 20kHz
<b>Distortion (THD@2kHz):</b>	+4dB = .02%

# A8 205L Direct Input Recall Sheet

ARTIST:  
ENGINEER:  
DATE:

NOTES:  
DRAWN BY:  
STUDIO:

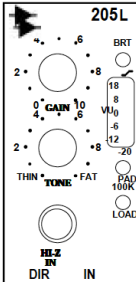
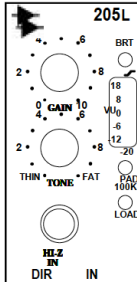
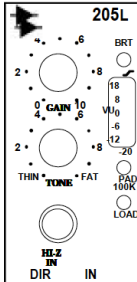
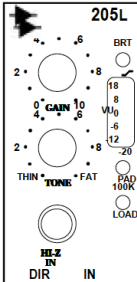
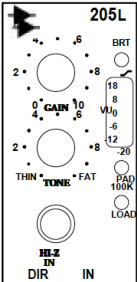
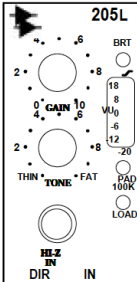
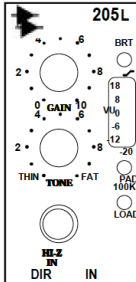
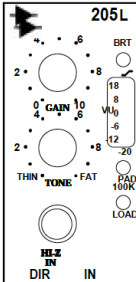
CHAN#	CHAN#	CHAN#	CHAN#	CHAN#	CHAN#	CHAN#	CHAN#
							
TITLE	TITLE	TITLE	TITLE	TITLE	TITLE	TITLE	TITLE
NOTES	NOTES	NOTES	NOTES	NOTES	NOTES	NOTES	NOTES

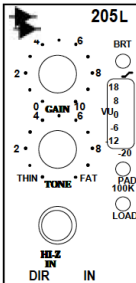
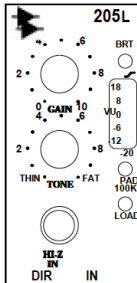
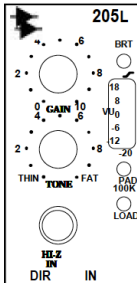
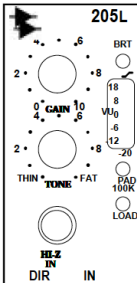
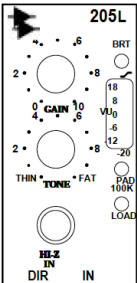
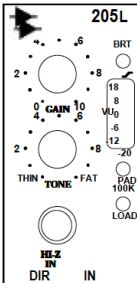
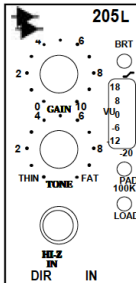
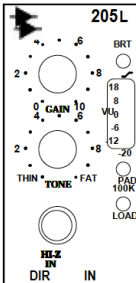
CHAN#	CHAN#	CHAN#	CHAN#	CHAN#	CHAN#	CHAN#	CHAN#
							
TITLE	TITLE	TITLE	TITLE	TITLE	TITLE	TITLE	TITLE
NOTES	NOTES	NOTES	NOTES	NOTES	NOTES	NOTES	NOTES

# A9 215L Sweep Filter Specifications

<b>Website:</b>	<a href="https://apiaudio.com/product/215l-hp-lp-sweep-filter/">https://apiaudio.com/product/215l-hp-lp-sweep-filter/</a>
<b>Number of Bands:</b>	Two
<b>Filter Type:</b>	Passive sweepable shelf
<b>Frequency Centers:</b>	Low Pass: 500Hz to 20kHz High Pass: 20Hz to 600Hz
<b>Input Impedance:</b>	>20K Ohms, balanced
<b>Output Impedance:</b>	85 Ohms, transformer coupled, balanced
<b>Nominal Levels:</b>	-15dBu to +15dBu
<b>Clipping Level:</b>	+28dBu
<b>Frequency Response:</b>	0, -.3, 30Hz to 20kHz
<b>Noise (Actual Measured):</b>	98dB below +10dBm output unweighted 20Hz to 20kHz
<b>Distortion (THD@2kHz):</b>	+4dB = .02%

# A10 225L Compressor/Limiter Specifications

**Website:** <https://apiaudio.com/product/225l-compressor/>

# A11 225L Compressor/Limiter Recall Sheet

ARTIST:  
ENGINEER:  
DATE:

NOTES:  
DRAWN BY:  
STUDIO:

CHAN #	CHAN #	CHAN #	CHAN #	CHAN #	CHAN #	CHAN #	CHAN #
TITLE	TITLE	TITLE	TITLE	TITLE	TITLE	TITLE	TITLE
NOTES	NOTES	NOTES	NOTES	NOTES	NOTES	NOTES	NOTES

CHAN #	CHAN #	CHAN #	CHAN #	CHAN #	CHAN #	CHAN #	CHAN #
TITLE	TITLE	TITLE	TITLE	TITLE	TITLE	TITLE	TITLE
NOTES	NOTES	NOTES	NOTES	NOTES	NOTES	NOTES	NOTES

# A12 235L Gate/Expander Specifications

**Website:** <https://apiaudio.com/product/235l-noise-gate/>

**Threshold Range:** -45dBu to +25dBu

**Depth Range:** 0 to -80dB, Fine adjust control, -9 at 50% rotation

**Attack Time:** Fast: 100 $\mu$ S

Normal: 25mS gate @90% open

**Release Time:** 50mS to 3 seconds

**Input Impedance:** >20K Ohms, balanced

**Output Impedance:** 85 Ohms, transformer coupled, balanced

**Nominal Levels:** -45dBu to +20dBu

**Clipping Level:** +28dBu

**Frequency Response:** 0, -.3, 30Hz to 20kHz

**Noise:** Gate closed: -102dBu unweighted

Gate open: -90dBu unweighted

**Distortion (Gate Open THD):** -40dBu = .3%

-30dBu = .1%

-20dBu = .03%

-10dBu = .01%

+4 = .008%

+12 = .01%

+28 = .1%

# A13 235L Noise Gate Recall Sheet

ARTIST:  
ENGINEER:  
DATE:

NOTES:  
DRAWN BY:  
STUDIO:

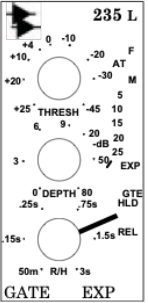
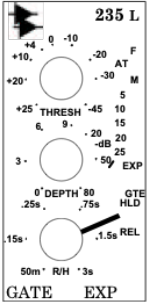
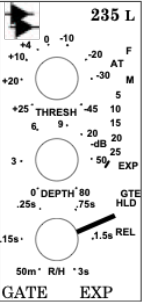
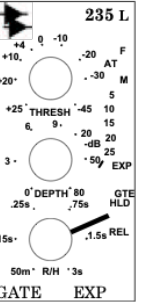
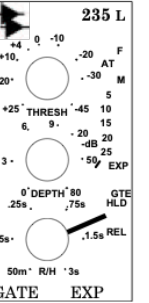
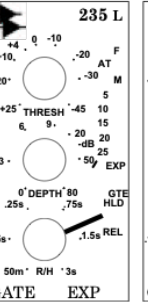
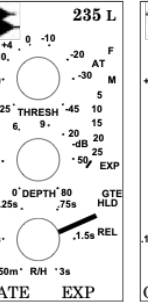
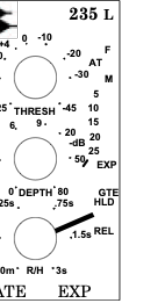
CHAN #	CHAN #	CHAN #	CHAN #	CHAN #	CHAN #	CHAN #	CHAN #
							
TITLE	TITLE	TITLE	TITLE	TITLE	TITLE	TITLE	TITLE
NOTES	NOTES	NOTES	NOTES	NOTES	NOTES	NOTES	NOTES

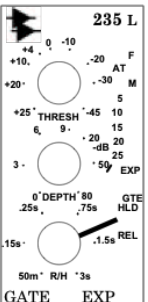
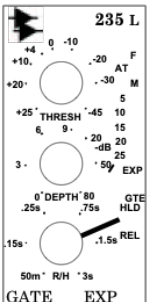
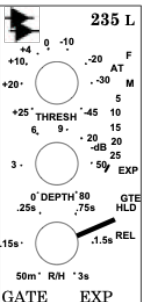
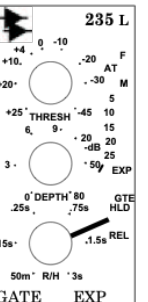
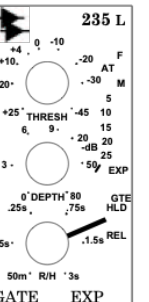
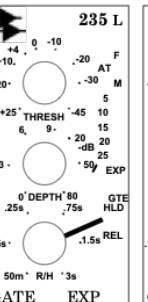
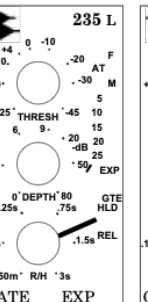
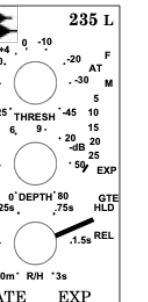
CHAN #	CHAN #	CHAN #	CHAN #	CHAN #	CHAN #	CHAN #	CHAN #
							
TITLE	TITLE	TITLE	TITLE	TITLE	TITLE	TITLE	TITLE
NOTES	NOTES	NOTES	NOTES	NOTES	NOTES	NOTES	NOTES

# A14 550AL 3-Band EQ Specifications

**Website\*:** <https://apiaudio.com/product/550a-discrete-3-band-eq/>

<b>Number of Bands:</b>	Four
<b>Boost/Cut:</b>	± 12dB
<b>Input Impedance:</b>	66K Ohms high level 17K Ohms low level
<b>Output Impedance:</b>	< 85 Ohms, (transformer)
<b>Nominal Levels:</b>	-15dBm to +12dBm
<b>Insertion Loss:</b>	None (bridging)
<b>Clipping Level (3% THD):</b>	+20dBu
<b>Frequency Response:</b>	± 0.5dB, 30Hz to 20kHz
<b>Noise:</b>	Unequalized: -90dB high-level strapping -98dBm low-level strapping 20Hz to 20kHz unweighted
<b>Distortion (THD):</b>	.05% max, 30Hz to 20kHz @ +4dBm .07% max, 30Hz to 20kHz @ +18dBm

\*The 550AL is the console version of the 550A EQ.

# A15 550AL 3-Band EQ Recall Sheet

**ARTIST:**  
**ENGINEER:**  
**DATE:**

**NOTES:**  
**DRAWN BY:**  
**STUDIO:**

TITLE	TITLE	TITLE	TITLE	TITLE	TITLE	TITLE	TITLE
<p>550A</p> <p>2.5 - 2 0 2 + 4 4</p> <p>5 6 6 9 9</p> <p>7 12 12 20 9 9</p> <p>HF 10 12.5 15 kHz - 2 0 2 + .2 4 4</p> <p>.4 6 6 9 9</p> <p>.6 12 12 5 9 9</p> <p>MF .8 1.5 3 kHz - 2 0 2 + 30 4 4</p> <p>40 6 6 9 9</p> <p>50 12 12 400 9 9</p> <p>LF 100 200 300 Hz</p> <p>FLTR</p> <p>L F H/F IN</p>	<p>550A</p> <p>2.5 - 2 0 2 + 4 4</p> <p>5 6 6 9 9</p> <p>7 12 12 20 9 9</p> <p>HF 10 12.5 15 kHz - 2 0 2 + .2 4 4</p> <p>.4 6 6 9 9</p> <p>.6 12 12 5 9 9</p> <p>MF .8 1.5 3 kHz - 2 0 2 + 30 4 4</p> <p>40 6 6 9 9</p> <p>50 12 12 400 9 9</p> <p>LF 100 200 300 Hz</p> <p>FLTR</p> <p>L F H/F IN</p>	<p>550A</p> <p>2.5 - 2 0 2 + 4 4</p> <p>5 6 6 9 9</p> <p>7 12 12 20 9 9</p> <p>HF 10 12.5 15 kHz - 2 0 2 + .2 4 4</p> <p>.4 6 6 9 9</p> <p>.6 12 12 5 9 9</p> <p>MF .8 1.5 3 kHz - 2 0 2 + 30 4 4</p> <p>40 6 6 9 9</p> <p>50 12 12 400 9 9</p> <p>LF 100 200 300 Hz</p> <p>FLTR</p> <p>L F H/F IN</p>	<p>550A</p> <p>2.5 - 2 0 2 + 4 4</p> <p>5 6 6 9 9</p> <p>7 12 12 20 9 9</p> <p>HF 10 12.5 15 kHz - 2 0 2 + .2 4 4</p> <p>.4 6 6 9 9</p> <p>.6 12 12 5 9 9</p> <p>MF .8 1.5 3 kHz - 2 0 2 + 30 4 4</p> <p>40 6 6 9 9</p> <p>50 12 12 400 9 9</p> <p>LF 100 200 300 Hz</p> <p>FLTR</p> <p>L F H/F IN</p>	<p>550A</p> <p>2.5 - 2 0 2 + 4 4</p> <p>5 6 6 9 9</p> <p>7 12 12 20 9 9</p> <p>HF 10 12.5 15 kHz - 2 0 2 + .2 4 4</p> <p>.4 6 6 9 9</p> <p>.6 12 12 5 9 9</p> <p>MF .8 1.5 3 kHz - 2 0 2 + 30 4 4</p> <p>40 6 6 9 9</p> <p>50 12 12 400 9 9</p> <p>LF 100 200 300 Hz</p> <p>FLTR</p> <p>L F H/F IN</p>	<p>550A</p> <p>2.5 - 2 0 2 + 4 4</p> <p>5 6 6 9 9</p> <p>7 12 12 20 9 9</p> <p>HF 10 12.5 15 kHz - 2 0 2 + .2 4 4</p> <p>.4 6 6 9 9</p> <p>.6 12 12 5 9 9</p> <p>MF .8 1.5 3 kHz - 2 0 2 + 30 4 4</p> <p>40 6 6 9 9</p> <p>50 12 12 400 9 9</p> <p>LF 100 200 300 Hz</p> <p>FLTR</p> <p>L F H/F IN</p>	<p>550A</p> <p>2.5 - 2 0 2 + 4 4</p> <p>5 6 6 9 9</p> <p>7 12 12 20 9 9</p> <p>HF 10 12.5 15 kHz - 2 0 2 + .2 4 4</p> <p>.4 6 6 9 9</p> <p>.6 12 12 5 9 9</p> <p>MF .8 1.5 3 kHz - 2 0 2 + 30 4 4</p> <p>40 6 6 9 9</p> <p>50 12 12 400 9 9</p> <p>LF 100 200 300 Hz</p> <p>FLTR</p> <p>L F H/F IN</p>	<p>550A</p> <p>2.5 - 2 0 2 + 4 4</p> <p>5 6 6 9 9</p> <p>7 12 12 20 9 9</p> <p>HF 10 12.5 15 kHz - 2 0 2 + .2 4 4</p> <p>.4 6 6 9 9</p> <p>.6 12 12 5 9 9</p> <p>MF .8 1.5 3 kHz - 2 0 2 + 30 4 4</p> <p>40 6 6 9 9</p> <p>50 12 12 400 9 9</p> <p>LF 100 200 300 Hz</p> <p>FLTR</p> <p>L F H/F IN</p>
<b>NOTES</b>	<b>NOTES</b>	<b>NOTES</b>	<b>NOTES</b>	<b>NOTES</b>	<b>NOTES</b>	<b>NOTES</b>	<b>NOTES</b>

# A16 550L 4-Band EQ Specifications

**Website:** <https://apiaudio.com/product/550b-4-band-eq/>

<b>Number of Bands:</b>	Four
<b>Boost/Cut:</b>	$\pm 12$ dB
<b>Slope:</b>	12dB/octave
<b>Input Impedance:</b>	18.5K Ohms @ +4 7.5K Ohms @ -2
<b>Output Impedance:</b>	< 75 Ohms
<b>Nominal Levels:</b>	-15dBu to +15dBu
<b>Clipping Level:</b>	+30dBu @ $\pm 16$ V
<b>Frequency Response:</b>	+0, -.3, 30Hz to 20kHz
<b>Noise:</b>	-98dBu, 20Hz to 20kHz unweighted
<b>Distortion (THD):</b>	.07% max @ +18dBu output

\*The 550L is the console version of the 550b EQ.

# A17 550L 4-Band EQ Recall Sheet

ARTIST:  
ENGINEER:  
DATE:

NOTES:  
DRAWN BY:  
STUDIO:

CHAN #	CHAN #	CHAN #	CHAN #	CHAN #	CHAN #	CHAN #	CHAN #
--------	--------	--------	--------	--------	--------	--------	--------

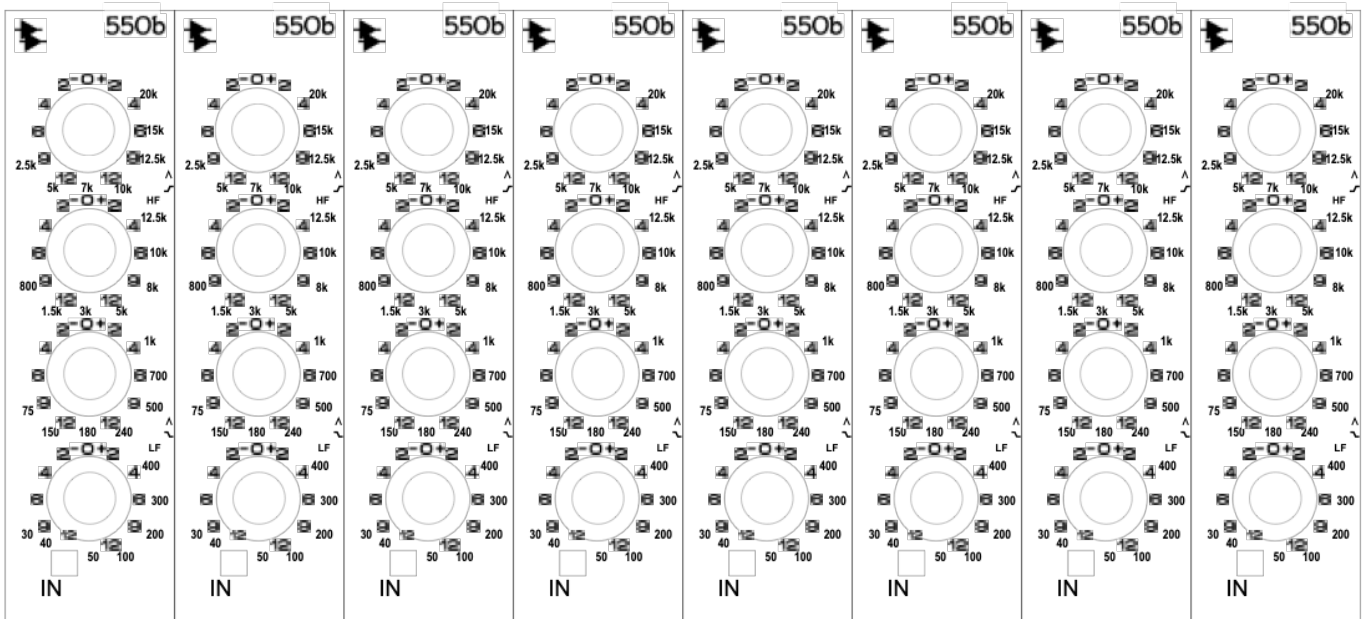

TITLE	TITLE	TITLE	TITLE	TITLE	TITLE	TITLE	TITLE
NOTES	NOTES	NOTES	NOTES	NOTES	NOTES	NOTES	NOTES

# A18 560L 10-Band Graphic EQ Specifications

**Website:** <https://apiaudio.com/product/560-graphic-eq/>

<b>Number of Bands:</b>	10
<b>Boost/Cut:</b>	± 12dB
<b>Slope:</b>	12dB/octave at full boost or cut
<b>Input Impedance:</b>	20K Ohms, resistive, balanced
<b>Output Impedance:</b>	< 85 Ohms
<b>Nominal Levels:</b>	-15dBu to +15dBu
<b>Clipping Level:</b>	Better than +28dBu
<b>Frequency Response:</b>	+0, -.25, 30Hz to 20kHz
<b>Noise:</b>	-95dBu EQ out -90dBu EQ in 20Hz to 20kHz unweighted
<b>Distortion (THD):</b>	.05% max @ +20dBu output

\*The 560L is the console version of the 560 EQ.

# A19 560L 10-Band Graphic EQ Recall Sheet

ARTIST:  
ENGINEER:  
DATE:

NOTES:  
DRAWN BY:  
STUDIO:

CHAN #	CHAN #	CHAN #	CHAN #	CHAN #	CHAN #	CHAN #	CHAN #
--------	--------	--------	--------	--------	--------	--------	--------

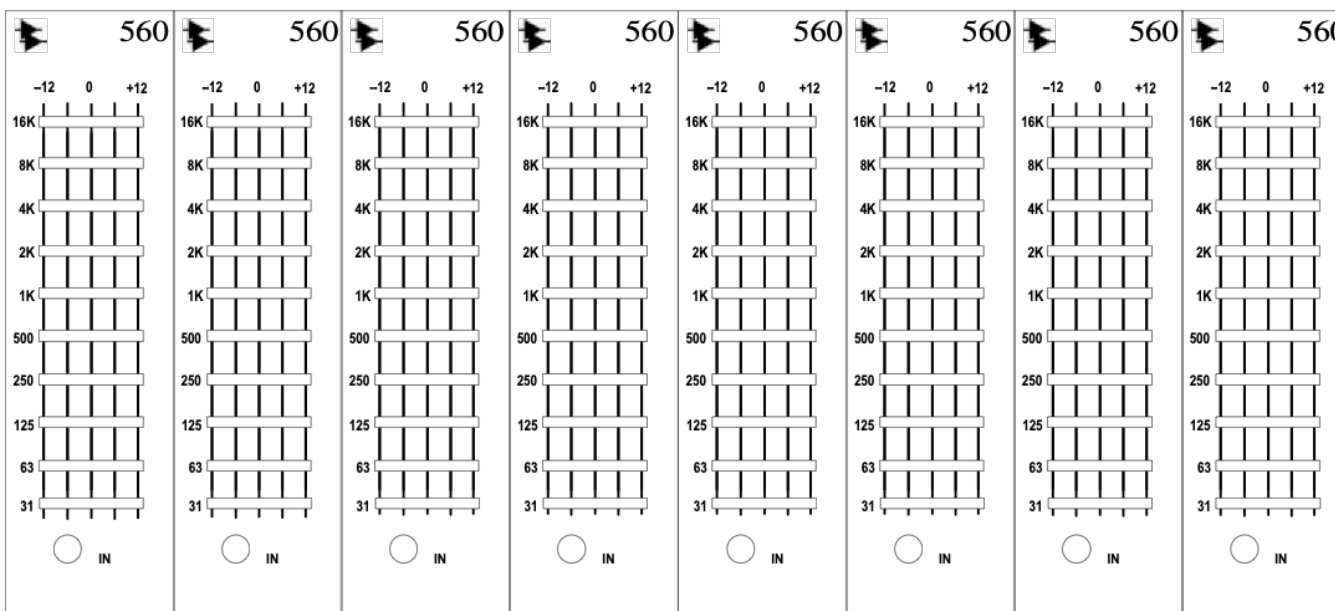

TITLE	TITLE	TITLE	TITLE	TITLE	TITLE	TITLE	TITLE
NOTES	NOTES	NOTES	NOTES	NOTES	NOTES	NOTES	NOTES

# A20 2500+C Bus Compressor Specifications

**Website:** <https://apiaudio.com/product/2500-stereo-bus-compressor/>

**Manual:** <https://www.apiaudio.com/docs/manuals/2500+ user 23-01-09.pdf>

**Input Impedance:** 60K Ohms, balanced

**Output Impedance:** 75 Ohms, transformer coupled, balanced

**Nominal Levels:** -15dBu to +15dBu

**Maximum Output Level:** +32dBu

**Frequency Response:**  $\pm 0.5\text{dB}$ , 20Hz to 50kHz

**Signal-to-Noise:** -120dB

\*The 2500+C is the console version of the 2500+ stereo bus compressor.

## A21 2500+C Bus Compressor Block Diagram

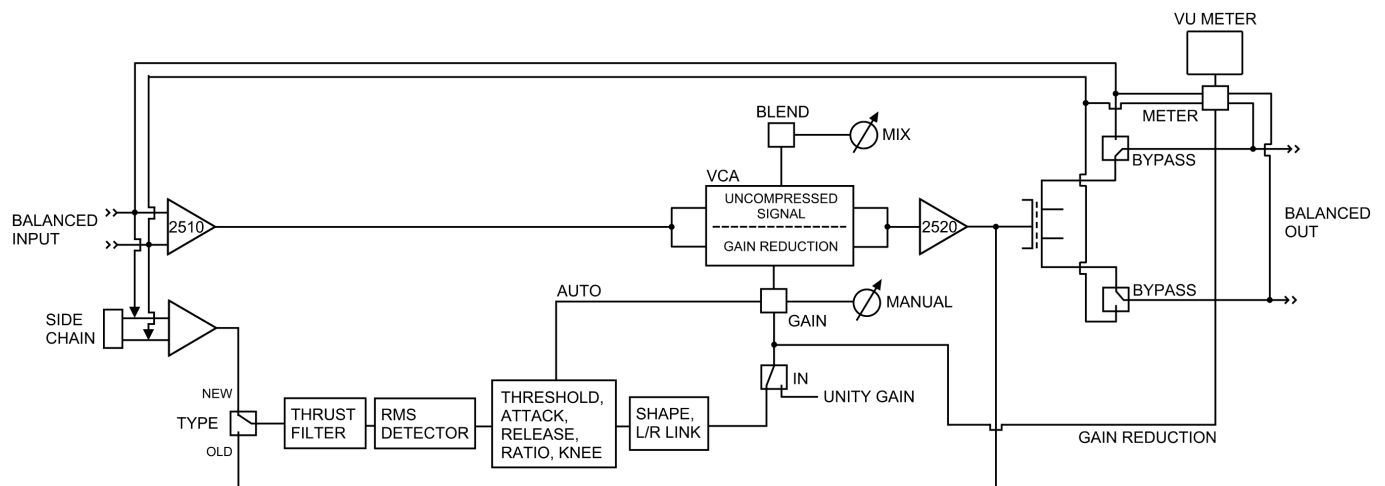

# A22 2500+C Bus Compressor Recall Sheet

ARTIST:  
ENGINEER:  
DATE:

NOTES:  
DRAWN BY:  
STUDIO:

<p><b>COMPRESSOR</b></p> <p>0 +8 0 -4 -12 +20 THRESH</p> <p>0.3 1 3 4 6 10 15 20 30 0.03 0.1 0.3 0.6 1 1.5 2 3 4 6 10 15 20 30 ATTACK</p> <p>0.1 0.2 0.5 1 2 3 4 6 10 15 20 30 0.01 0.05 0.1 0.2 0.5 1 2 3 4 6 10 15 20 30 RATIO</p> <p>0.1 0.2 0.5 1 2 3 4 6 10 15 20 30 0.01 0.05 0.1 0.2 0.5 1 2 3 4 6 10 15 20 30 RELEASE</p> <p>0.1 0.2 0.5 1 2 3 4 6 10 15 20 30 0.01 0.05 0.1 0.2 0.5 1 2 3 4 6 10 15 20 30 VARIABLE</p>	<p><b>tone</b></p> <p>HARD LOUD MED MED NEW FREQ SOFT NORM OLD FREQ</p> <p>thrash KNEE detector THRUST tone TYPE</p>	<p><b>LINK</b></p> <p>60 70 80 90 FAST 50 100 SLOW IND filter SHAPE</p> <p>percent L/R LINK</p>	<p><b>OUTPUT</b></p> <p>IN BYP MANUAL 6 9 12 20 30 40 50 60 3 18 24 30 40 50 60 80 make-up GAIN dB GAIN BLEND 0 100 comp MIX</p>			<p><b>VU</b></p> <p>GR OUT IN SOURCE METER</p>
---	--	---	--	--	--	--

NOTES:

<p><b>COMPRESSOR</b></p> <p>0 +8 0 -4 -12 +20 THRESH</p> <p>0.3 1 3 4 6 10 15 20 30 0.03 0.1 0.3 0.6 1 1.5 2 3 4 6 10 15 20 30 ATTACK</p> <p>0.1 0.2 0.5 1 2 3 4 6 10 15 20 30 0.01 0.05 0.1 0.2 0.5 1 2 3 4 6 10 15 20 30 RATIO</p> <p>0.1 0.2 0.5 1 2 3 4 6 10 15 20 30 0.01 0.05 0.1 0.2 0.5 1 2 3 4 6 10 15 20 30 RELEASE</p> <p>0.1 0.2 0.5 1 2 3 4 6 10 15 20 30 0.01 0.05 0.1 0.2 0.5 1 2 3 4 6 10 15 20 30 VARIABLE</p>	<p><b>tone</b></p> <p>HARD LOUD MED MED NEW FREQ SOFT NORM OLD FREQ</p> <p>thrash KNEE detector THRUST tone TYPE</p>	<p><b>LINK</b></p> <p>60 70 80 90 FAST 50 100 SLOW IND filter SHAPE</p> <p>percent L/R LINK</p>	<p><b>OUTPUT</b></p> <p>IN BYP MANUAL 6 9 12 20 30 40 50 60 3 18 24 30 40 50 60 80 make-up GAIN dB GAIN BLEND 0 100 comp MIX</p>			<p><b>VU</b></p> <p>GR OUT IN SOURCE METER</p>
---	--	---	--	--	--	--

NOTES:

<p><b>COMPRESSOR</b></p> <p>0 +8 0 -4 -12 +20 THRESH</p> <p>0.3 1 3 4 6 10 15 20 30 0.03 0.1 0.3 0.6 1 1.5 2 3 4 6 10 15 20 30 ATTACK</p> <p>0.1 0.2 0.5 1 2 3 4 6 10 15 20 30 0.01 0.05 0.1 0.2 0.5 1 2 3 4 6 10 15 20 30 RATIO</p> <p>0.1 0.2 0.5 1 2 3 4 6 10 15 20 30 0.01 0.05 0.1 0.2 0.5 1 2 3 4 6 10 15 20 30 RELEASE</p> <p>0.1 0.2 0.5 1 2 3 4 6 10 15 20 30 0.01 0.05 0.1 0.2 0.5 1 2 3 4 6 10 15 20 30 VARIABLE</p>	<p><b>tone</b></p> <p>HARD LOUD MED MED NEW FREQ SOFT NORM OLD FREQ</p> <p>thrash KNEE detector THRUST tone TYPE</p>	<p><b>LINK</b></p> <p>60 70 80 90 FAST 50 100 SLOW IND filter SHAPE</p> <p>percent L/R LINK</p>	<p><b>OUTPUT</b></p> <p>IN BYP MANUAL 6 9 12 20 30 40 50 60 3 18 24 30 40 50 60 80 make-up GAIN dB GAIN BLEND 0 100 comp MIX</p>			<p><b>VU</b></p> <p>GR OUT IN SOURCE METER</p>
---	--	---	--	--	--	--

NOTES:

# A23 API Limited Warranty and Service

- a. **Warranty Information:** This product carries a one year labor and a five year parts warranty from date of purchase. API (Automated Processes, Incorporated) does not cover claims for damage due to alteration and/or abuse. This warranty is limited to failures during normal use, which are due to defects in material or workmanship. If any defects are found in the materials or workmanship, or if the product fails to function properly during the applicable warranty period, API, at its option, will repair or replace the product.
- b. **PLEASE NOTE:** The design or quality of any non-authorized third party service or vendor is beyond the control of API. Accordingly service or modification of any API unit except by an authorized API representative may VOID this warranty.
- c. API reserves the right to inspect any products that may be the subject of any warranty claims before repair or replacement is carried out. Final determination of warranty coverage lies solely with API.
- d. This warranty is extended to the original purchaser and to anyone who may subsequently purchase this product within the applicable warranty period. Proof of purchase may be required.
- e. For questions regarding operation, interfacing or service of your API product, please contact your API dealer from whom you purchased the unit. Many times your authorized API dealer is the fastest and most cost-effective way to maintain and service your product.
- f. You may also contact API's Service Department directly.
  - a. Call API at 301-776-7879 (ext. 252) between 8:30 AM and 5:00 PM Monday through Friday (Eastern Time) to get a Return Authorization (RA). Products returned without an RA number may not be accepted.
  - b. Pack the defective part by wrapping in plastic and cushioning material. Seal securely in an approved shipping container. If you do not have a sufficient shipping container, ask API for advice when calling for the RA number.
  - c. Include a note explaining the problem and conditions of the service request. Include your complete return address (no P.O. Boxes, please).
  - d. Ship the product freight prepaid to:

API  
8301 Patuxent Range Road  
Jessup, MD 20794

**IMPORTANT:** Be sure the RA number is plainly written on the shipping carton.

- g. This is your sole warranty. API does not authorize any third party, including any dealer or sales representative, to assume liability on behalf of API or to make any warranty for API.
- h. **THE WARRANTY GIVEN ON THIS PAGE IS THE SOLE WARRANTY GIVEN BY API AND IS IN LIEU OF ALL OTHER WARRANTIES, EXPRESS AND IMPLIED, INCLUDING THE WARRANTIES OF MERCHANTABILITY AND FITNESS FOR A PARTICULAR PURPOSE. THE WARRANTY GIVEN ON THIS PAGE SHALL BE STRICTLY LIMITED IN DURATION TO FIVE (5) YEARS FROM THE DATE OF THE ORIGINAL PURCHASE FROM API OR AN AUTHORIZED API DEALER. UPON**

**EXPIRATION OF THE APPLICABLE WARRANTY PERIOD API SHALL HAVE NO FURTHER WARRANTY OBLIGATION OF ANY KIND. API SHALL NOT BE LIABLE FOR ANY INCIDENTAL, SPECIAL, OR CONSEQUENTIAL DAMAGES THAT MAY RESULT FROM ANY DEFECT IN THE API PRODUCT OR ANY WARRANTY CLAIM.**

This warranty provides specific legal rights and you may have other rights, which vary from state to state.

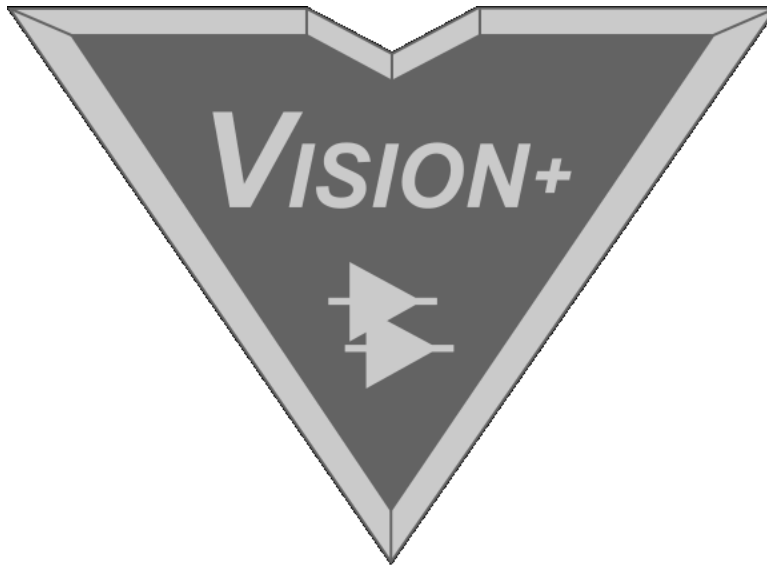

**Automated Processes, Inc.**

8301 Patuxent Range Road  
Jessup, MD 20794 USA  
301-776-7879

<http://www.apiaudio.com>