



The API

2500

Stereo Bus



# A BASIC OVERVIEW OF THE API 2500 COMPRESSOR

Thank you for choosing the API 2500 Stereo Bus Compressor. The 2500 has several unique features that will allow you to tailor the sound of the compression in many different directions. There are two features that can only be found on this unit, as they are either patented or patent-pending.

The patented "THRUST" feature has been used for many years in the famed ATI Paragon and Paragon II consoles as well as the Pro-6 Input Strip. This circuit places a filter in front of the RMS detector, with a slope of 10dB per decade, which is the inverse of the pink noise energy curve. In acoustics, the pink noise curve is used to equalize energy vs. frequency over the audio spectrum, as sound requires more low frequency energy than high frequency energy to sound correct to your ear. In Hi-Fi equipment, a "LOUDNESS" contour is used to equalize the music at lower levels so it sounds correct. Even with this curve, there is still a substantial amount of low frequency information compared to high frequency information in the audio signal path. When that signal is fed into an RMS detector, the detector will process the signal into a DC control voltage based on those louder low frequencies, resulting in a control voltage that favors the low frequencies of the signal, causing pumping and a loss of punch. Sometimes, this is not desirable. By switching the THRUST button in either the MED or LOUD positions, this inverse filter is placed in front of the RMS detector, evening out the energy by lowering the energy in the low frequencies and increasing the energy in the high frequencies, so each octave has the same energy instead of each octave having half the energy as the one lower. This creates a unique compression effect that still reduces the overall gain, but the sound is much more punchy and the signal actually sounds much less compressed.

The LINK feature is also unique to the 2500. First, there is a variable link control, ranging from IND (independent) to 50% through 100%. The variable linking allows combining of the left and right control voltages over a range, minimizing the interaction between channels, while still linking them to retain the stereo image. While engaged, the LINK control has a selectable HI-Pass, LOW-Pass and BAND Pass filter that can be inserted, but only into the LINK circuit. This feature can reduce peaks from cross-linking, reduce low frequencies from cross-linking or both. The value of this feature is shown when the signal contains a large amount of percussive instruments, spread around the stereo field. When all other compressors are linked, any peak in the left side will result in a gain reduction in the right side that will shift the stereo image, resulting in a less than desirable effect. By inserting the high or low pass filters, you can eliminate this undesired image shift while still linking the preferred frequency range.

The 2500 has two complete, identical compressor circuits, from the input through the RMS detector, the VCA's and to the Output section. When many compressors are linked to the "STEREO LINK" mode, only one channel is controlling the compression. When the 2500 is linked, the control voltages are summed together, but both channels are still detecting their own control voltages. This also eliminates changing of the tone of the compressor when linking is used. Many popular units actually change when linked!

Additionally, each channel used three VCA's to minimize noise and distortion found in single and dual VCA compressors. The signal path from the input to the output is ALL DISCRETE, using the API 2510 and the API 2520.

The GAIN pot can be either switched IN for manual gain control, or it can be left OUT and the 2500 will bring the output level up and down automatically, keeping the signal at the same level regardless of where the THRESH or RATIO controls are set. This is the same as the API 525 Ceiling control.

Just to the right of the VU meters, there is a set screw adjustment. This adjustment is to rock or tilt the signal left or right when in the auto gain mode, allowing subtle corrections in the stereo image if it is off center when compressing. This control only affects the image when the 2500 is above the threshold, and does not do anything when the signal is not being compressed. Usually, this control should be in a vertical position.

*One tip to get started: We try to design all of our processing modules with the understanding that there is never enough time to read a manual and learn all of the features in the 10 seconds that is allowed during a setup. If you simply place all of the knobs at the 12:00 position, the 2500, and all of the 200 series modules will have a useful, but conservative effect on the signal.*

# THRUST Filter Before the RMS Detector

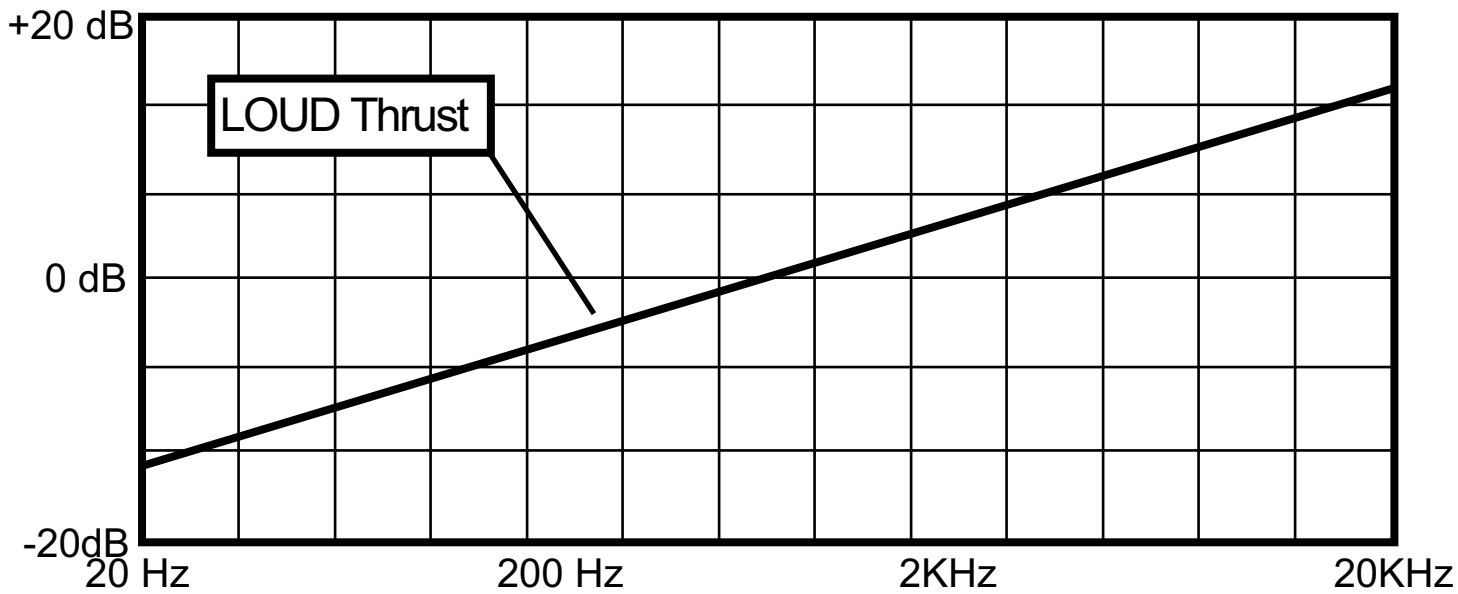
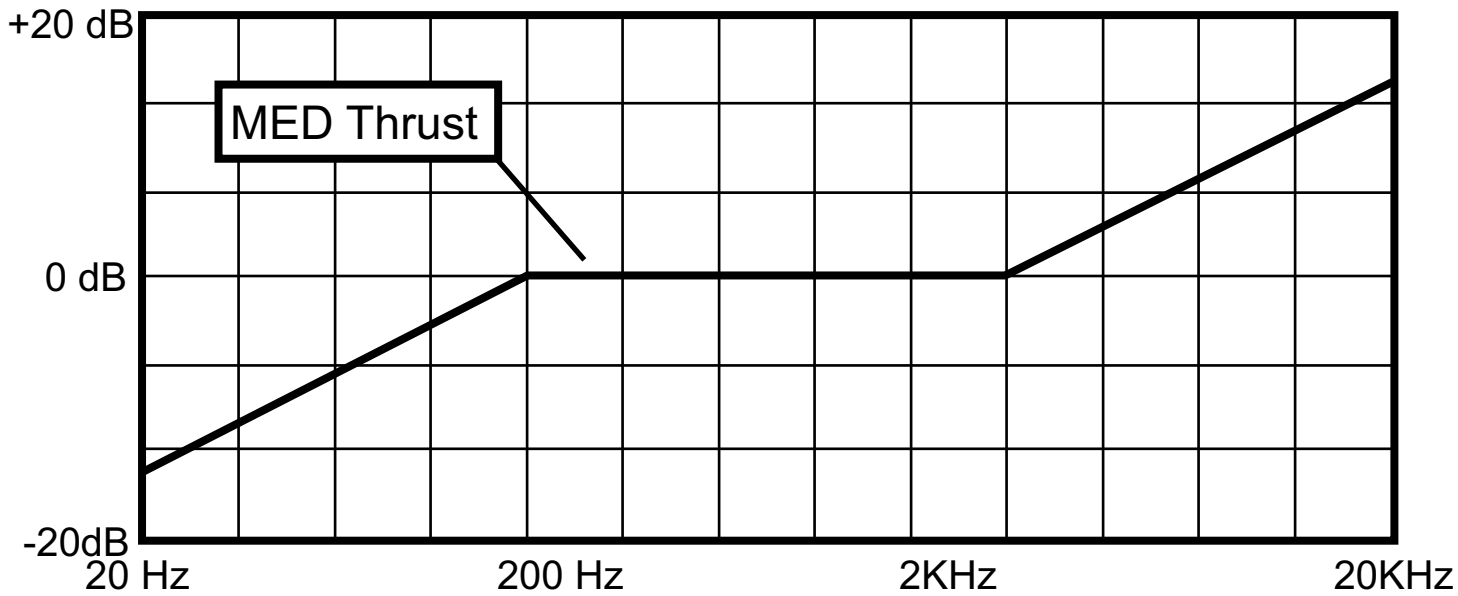
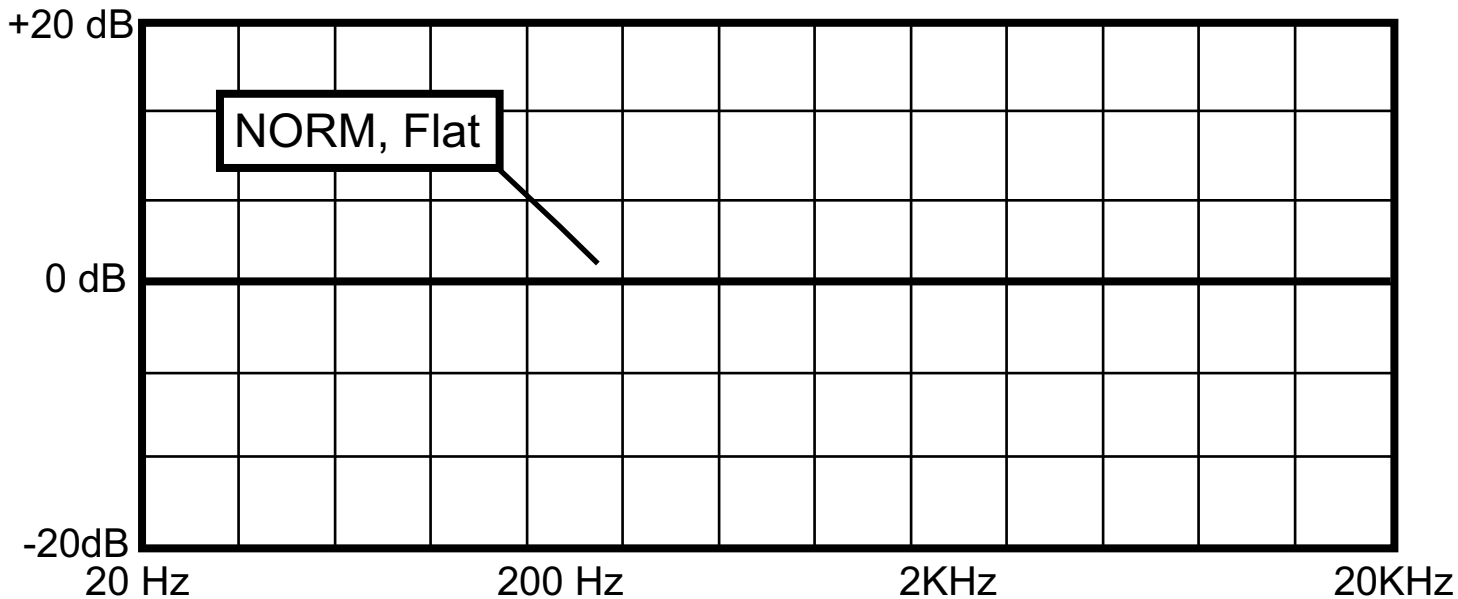

# Compression KNEE at the Threshold Point

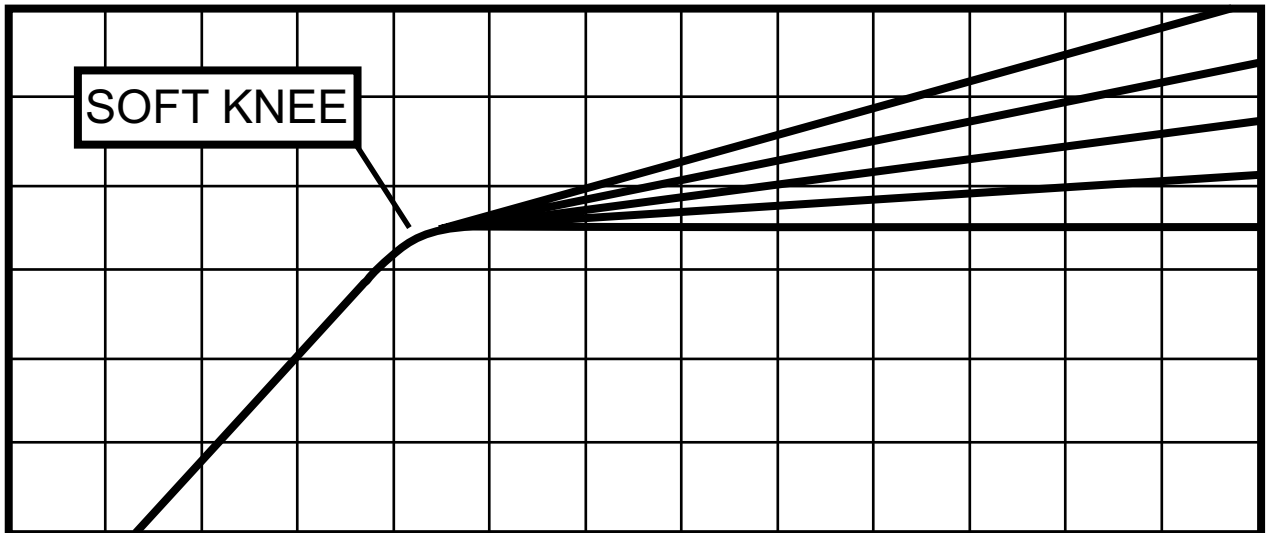
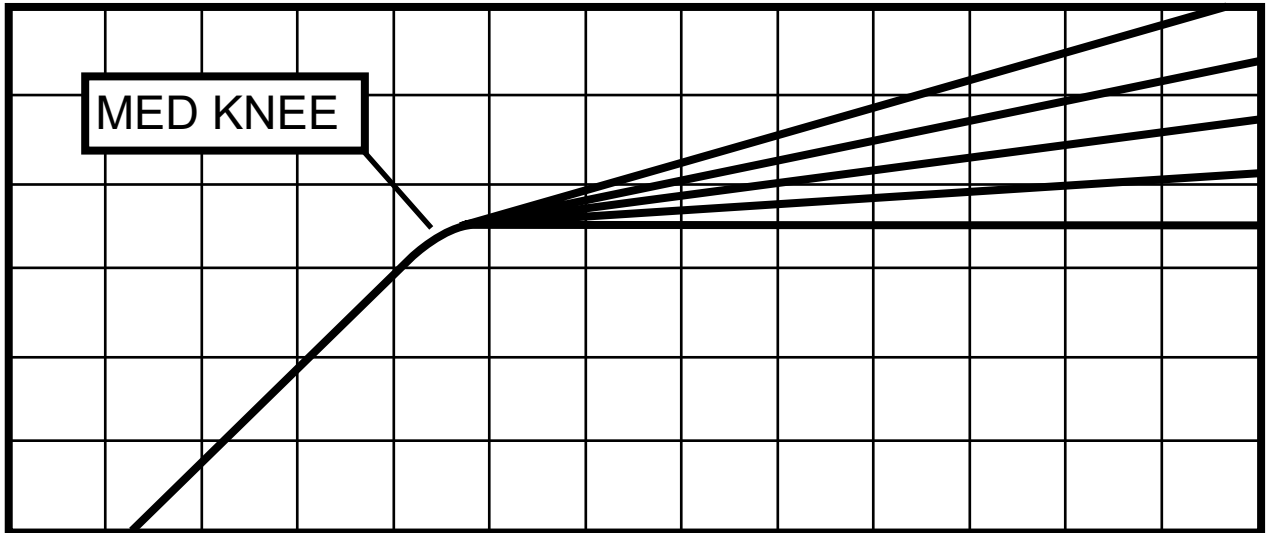
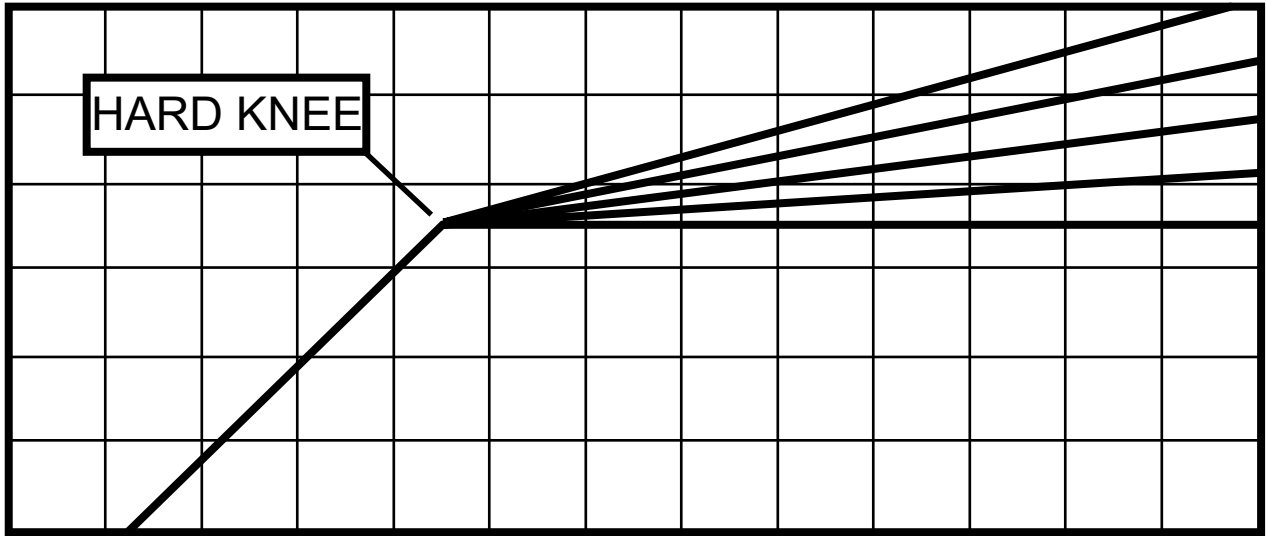

# "NEW" or FEED FORWARD type COMPRESSION

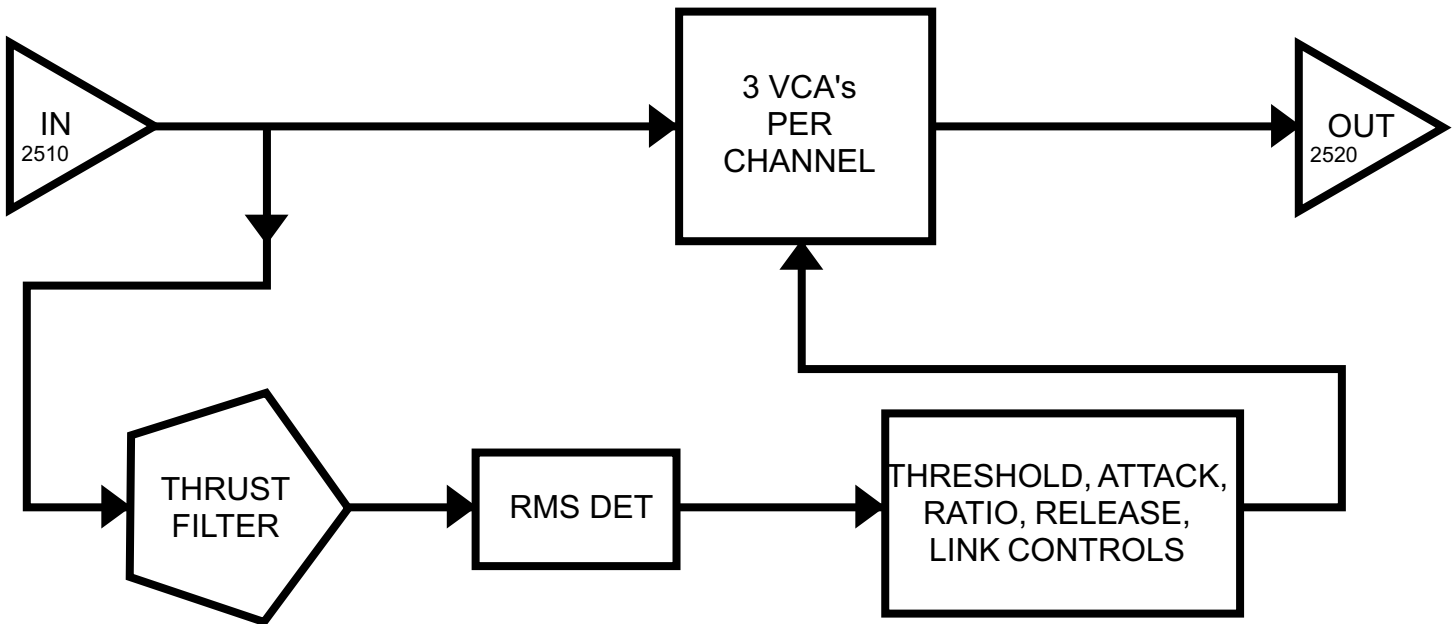

# "OLD" or FEED BACK type COMPRESSION

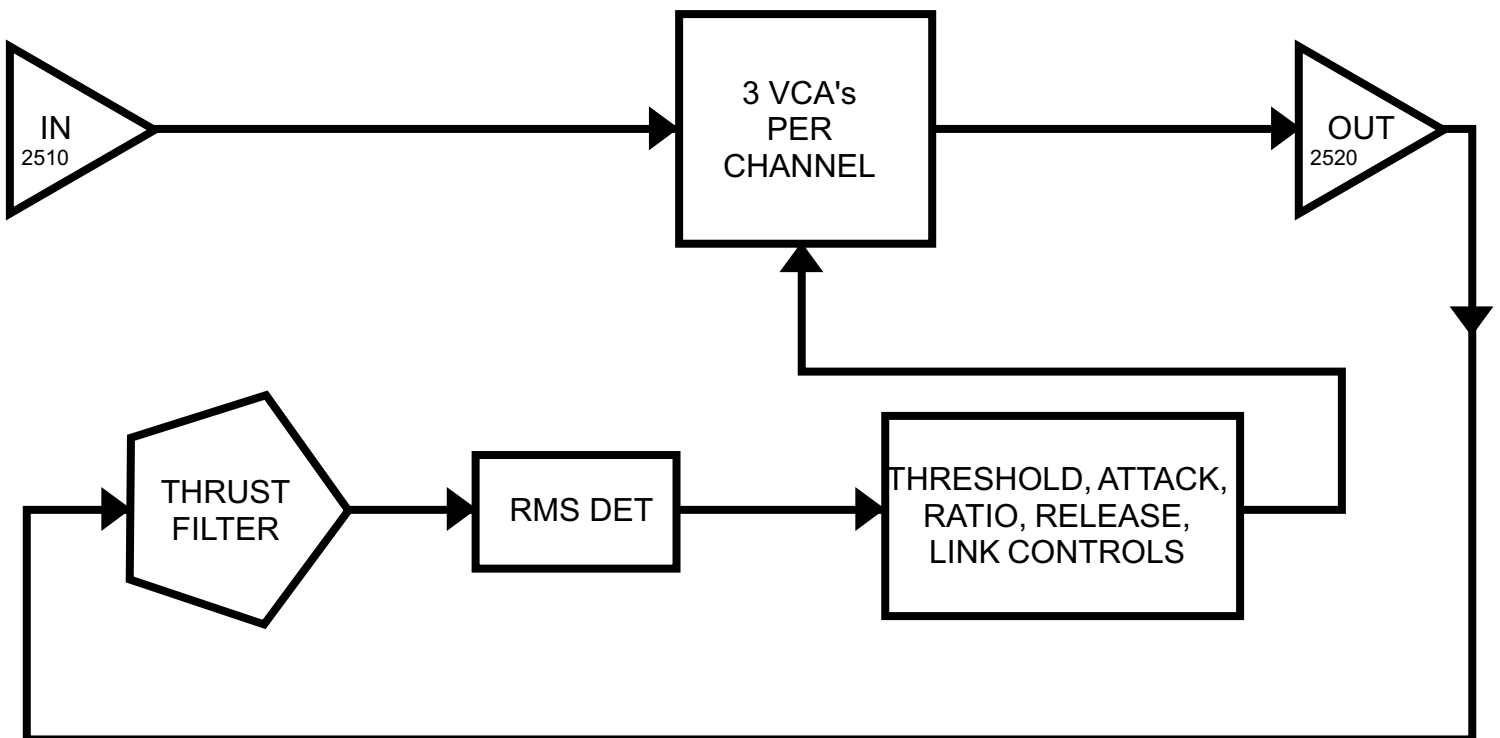

# Compressor Section

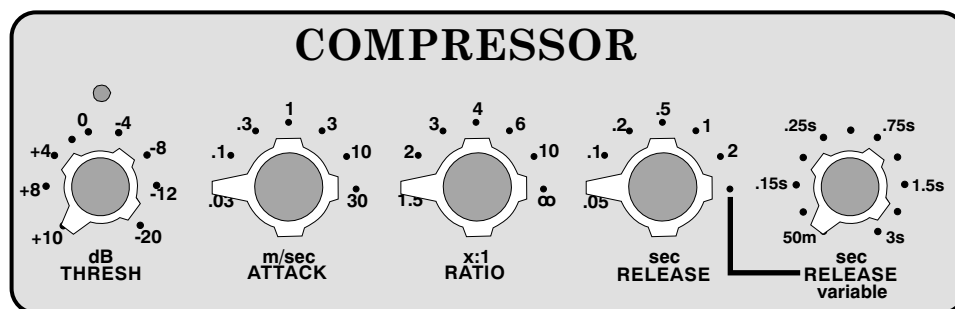

## THRESH:

This control sets the THRESHHOLD from +10 dBu to -20 dBu. Both channels are set independently with this control. Each channel has its own RMS detector and can operate as two single compressors or one stereo compressor. Even when using the LINK control, each channel ALWAYS has its own RMS detector for accuracy. This control is continuously variable. The THRESH control also effects the gain when in the AUTO gain make-up mode.

## ATTACK:

This control sets the ATTACK time of each channel from 30 microseconds to 30 milliseconds. There are seven positions to choose from, 30u/sec, 100u/sec, 300u/sec, 1 m/sec, 3 m/sec, 10 m/sec and 30 m/sec. This rotary switch allows repeatability, while offering a wide range of settings.

## RATIO:

This control sets the compression RATIO of each channel from 1.5:1 to INF:1 or above 20:1. There are seven positions to choose from, 1.5:1, 2:1, 3:1, 4:1, 6:1, 10:1 and INF:1. This rotary switch allows repeatability while offering a wide range of settings. The RATIO control also affects the gain when in the AUTO gain make-up mode.

## RELEASE:

This control sets the RELEASE of each channel of the compressor, covering a wide range of release times including the last position, which switches it to the VARIABLE RELEASE control to the right of it. There are seven positions to choose from, 50m/sec., 100m/sec, 200m/sec., 500/m/sec, 1 sec, 2 sec, and VARIABLE.

## VARIABLE RELEASE:

This control sets the RELEASE time with a continuously variable pot covering a range from 50m/sec. to 3 seconds. This works when the RELEASE rotary switch control is fully clockwise. This allows for a continuously variable release, with the ability to match the "bounce" of a song with the release time.

# Tone Section

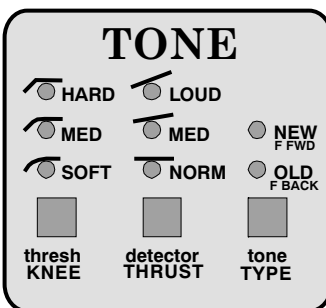

## **KNEE:**

This control sets the KNEE, or how the point where the compressor begins to reduce the gain of the signal applied to the unit. When in the HARD position, the gain reduction begins at the set ratio and is a sharp transition into compression. The MED position has a slight "fade-in" up to the set ratio. The SOFT position has a gradual "fade-in" to the set ratio. The HARD position is very noticeable and the SOFT position is very subtle and similar to an "over-easy" type KNEE.

## **THRUST:**

This control sets the THRUST, a patented circuit that inserts a hi-pass filter at the input of the RMS detector, limiting its response to lower frequencies. In the NORM mode, there is no filter and the 2500 compresses like most units on the market today. When MED is selected, there is a slight attenuation of the low frequencies and a slight boost of the high frequencies, with a flat midrange affecting the signal going into the RMS detector. This reduces the low frequencies from pumping the compressor as much and increases the sensitivity of the RMS detector to the higher frequencies, affecting the higher frequency peaks of the signal. When LOUD is selected, there is a gradual, linear filter, down 15 dB at 20 Hz and up 15dB at 20K Hz, equalizing the energy going into the RMS detector. This decreases the way the low frequencies pump the compressor and increases the way the higher frequencies are compressed. The overall difference is a noticeable increase of punch and low frequencies, but a uniformly compressed signal. It is the "little more punch" switch.

## **TYPE:**

This control sets the TYPE, or where the signal for the RMS detector comes from. In the NEW mode, the compressor works like most newer types of compressors, as in most of the VCA based units. This is called FEED-FORWARD compression, where the RMS detector sends a signal to the VCA that is an exact ratio of the desired compression, set by the RATIO control. When the OLD position is selected, the RMS detector gets the signal from the output of the VCA, and then feeds the VCA a signal based on a set ratio of that signal. This type of compression is called FEEDBACK compression and is how the older API 525, 1176 type and 660 type compressors worked. The NEW mode is much harder and the OLD mode is very smooth. When SOFT, LOUD, and OLD is selected you can hardly hear the compression.

# Link and Output Section

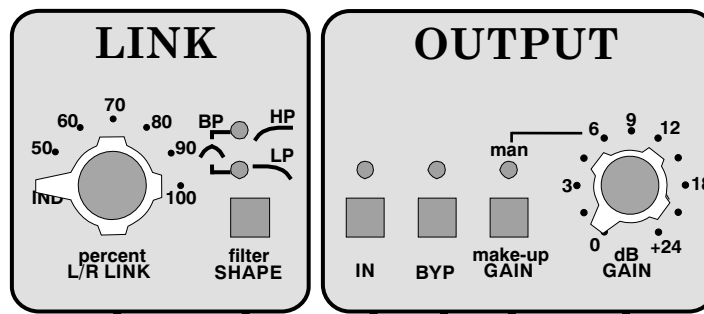

## L/R LINK:

This control sets the left to right LINK percentage. Most compressors only allow 100% linking between channels. The 2500 allows for linking starting at IND, which is 0% and 50% to 100% in six additional steps. At the same time, each channel is still controlled by its own detector, preventing loading and slaving from one side, which many times creates errors. This control mixed each channel's RMS detector controls together according to the switch position.

## SHAPE:

This control adjusts the SHAPE of the LINK control voltage mixing. There are two filters, a high pass filter, eliminating the lows, a low pass filter, eliminating the highs and a combination of both filters creating a band pass filter. The value of this circuit allows the LINK control voltage to NOT include certain frequencies, such as the low frequency end of each channel, preventing the low frequencies from linking from the left side to the right side, etc. When the different combinations of the filters are used, sounds like sharp percussive instruments on one channel will not couple to the other channel and cause it to compress.

## IN and BYPASS:

The IN switch is a soft IN/OUT button that defeats the compression action silently, but allows the signal to pass through the 2500.

The BYP switch is a relay hard-wire bypass that routes the signal directly from the input XLR to the output XLR, without going through any electronics. If the power fails to the 2500, the BYP automatically engages, preventing any loss of signal during the power fault.

## GAIN:

When the GAIN switch is pressed IN, the GAIN pot controls the amount of make-up gain added to maintain the desired overall gain after the compression action reduces the output level. When in the OUT position, the output make-up gain is automatically set as a result of the position of the THRESH or RATIO controls. If the input signal is below +4 dBu, rotating the THRESH control will increase the output level until the output level is around +4 dBu, and then as the signal gets compressed, it will maintain an even output level, allowing THRESH and RATIO adjustments without having to re-adjust the make-up gain. This is very useful during situations where an adjustment needs to be made without disturbing the output level to tape or air. This function is similar to the API 525 ceiling control.



# Metering and Trim Section

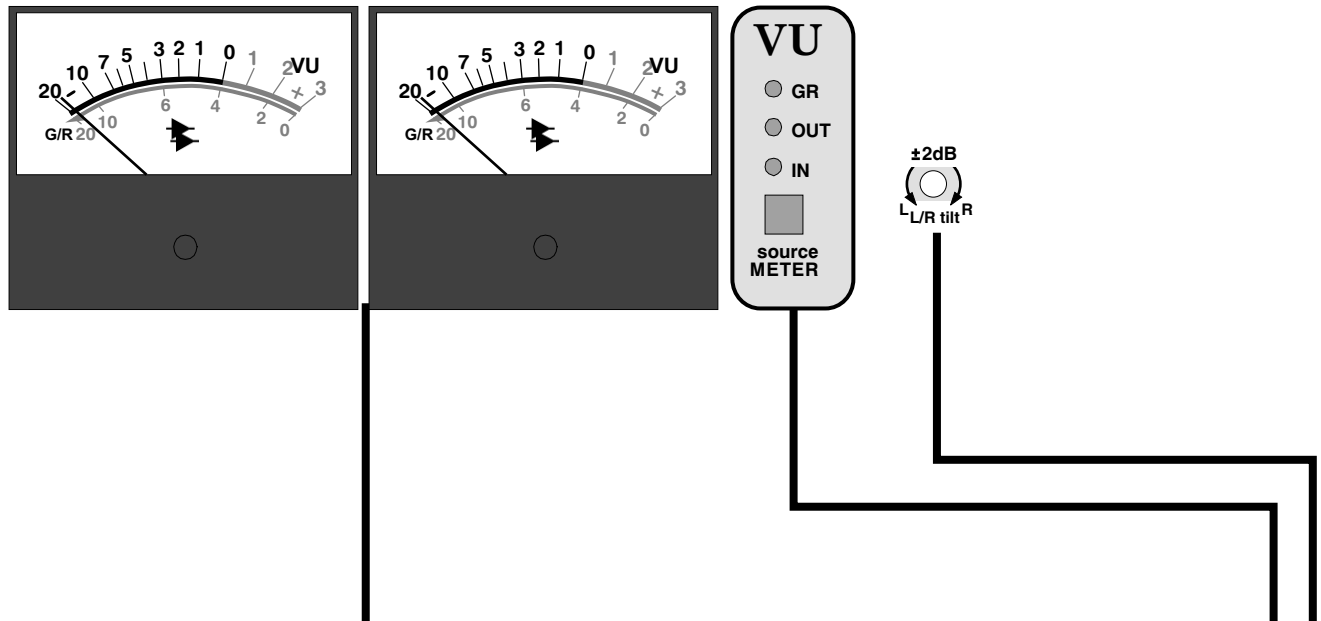

## VU METER:

The VU Meters displays the INPUT and OUTPUT levels in dBu, where +4dBu is 0 VU. This reference point can be adjusted internally to other reference levels.

The GAIN scale shows the amount of gain reduction during compression, with the 0 point being all the way to the right, allowing more resolution of the gain reduction scale. The range of the meter is from 0 (no gain reduction) to 20 db of gain reduction. The compressor can compress up to 30 dB of reduction.

## VU:

The VU switch selects the INPUT, OUTPUT or GAIN REDUCTION to be displayed on the VU meters. It is a silent function and is isolated so the VU selection does not effect or load the signal in any way.

## TILT:

The TILT adjustment is a trim of the compression control voltage, allowing tilting of the compression left or right to equalize uneven signal compression that may offset the stereo image. This control adjusts about 2 dB in either direction, and DOES NOT affect the uncompressed signal, which is always unity in to out.

This control is useful in a situation where there is a slight difference in the stereo image when a signal is compressed, but not when it is below the compression threshold. Normally, this control should be straight up.

**WARNING:** Adjusting this control will likely require your unit to be returned to the API factory to be re-calibrated!!

When in doubt, start with all the controls straight up...

**AC VOLTAGE SELECTOR**

Switch between 90-120 and 200-250VAC  
SWITCH IT ONLY WHEN THE POWER IS OFF



**FUSE HOLDER**

REPLACE WITH A TYPE  
0.5A slow-blow for 90-125 VAC  
0.25A slow-blow for 200-250 VAC

**AC INLET**

CHECK VOLTAGE  
SELECTOR BEFORE  
TURNING 2500 ON

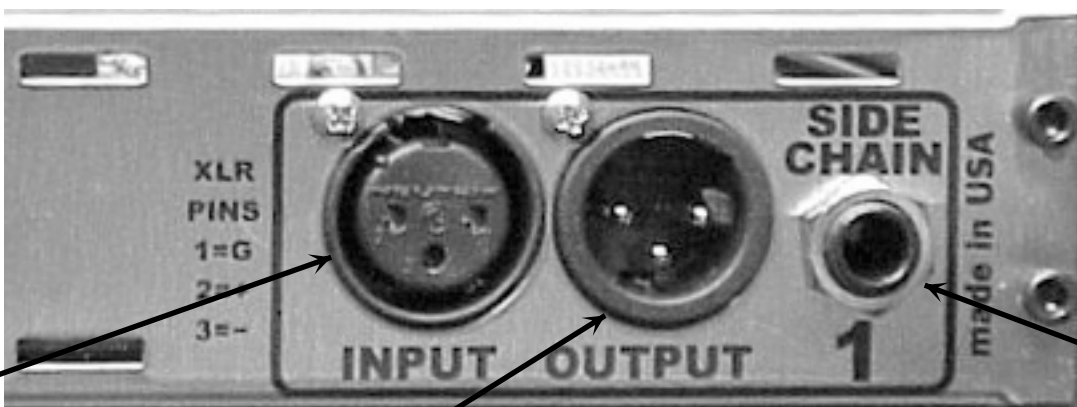

**XLR INPUT**  
+4dBu  
Pin 2 HOT

**XLR OUTPUT**  
+4 dBu  
Pin 2 HOT

**SIDE CHAIN  
INPUT , +4dBu**  
Normals to  
XLR INPUT

Record the serial number of your 2500 in the space below for your records. Should you ever need to contact the factory about this unit, please have this number handy.

serial no. found on rear \_\_\_\_\_